

Work done by Constant Force DPP-01

- 1. A force $\vec{F} = (3\hat{i} + 2\hat{j})\text{N}$ acts on a body and produces a displacement $\vec{S} = (4\hat{i} - \hat{j} + 3\hat{k})\text{m}$. The work done will be**

 - (1) 13 J
 - (2) 30 J
 - (3) 10 J
 - (4) 20 J
- 2. A body of mass m is displaced from point $A(3, 1, 3)$ to point $B(1, 2, 1)$ under the effect of a force $\vec{F} = (5\hat{i} + 2\hat{j} - 4\hat{k})\text{N}$, calculate work done by the force.**

 - (1) 57 J
 - (2) 11 J
 - (3) 0 J
 - (4) 22 J
- 3. The work done against gravity in taking 5 kg. mass to 2 m height in 1 s will be :-**

 - (1) 49 J
 - (2) 98 J
 - (3) 196 J
 - (4) None of these
- 4. A student of Allen is going from samarth to sabal building holding his bag in his hand. Direct distance between these buildings is 50 m. Calculate work done by gravity if mass of bag is 3 kg.**

 - (1) 750
 - (2) 1500
 - (3) Zero
 - (4) Data insufficient
- 5. You lift a heavy book from the floor of the room and keep it in the book-shelf having a height 2 m. In this process you take 5 seconds. The work done by you will depend upon :-**

 - (1) Mass of the book and time taken
 - (2) Weight of the book and height of the book-shelf
 - (3) Height of the book-shelf and time taken.
 - (4) Mass of the book, height of the book-shelf and time taken.

6. For the system shown in figure both the block A and B are moving together. If coefficient of friction between both the blocks is μ , the work done by friction on block B is :-

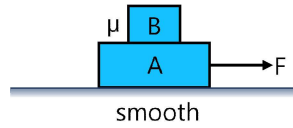

- (1) Zero
 (2) Negative
 (3) Positive
 (4) None of these
7. A body of mass M tied to a string is lowered at a constant acceleration of $(3g/4)$ through a vertical distance h . The work done by the string will be.....

- (1) $\frac{3}{4} Mgh$
 (2) $\frac{1}{4} Mgh$
 (3) $-\frac{3}{4} Mgh$
 (4) $-\frac{1}{4} Mgh$

8. Find work done by friction for displacement 'S' ?

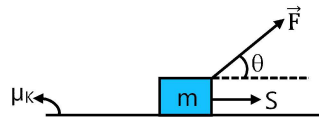

- (1) $\mu_k(mg + F \sin \theta)S$
 (2) $-\mu_k(mg + F \sin \theta)S$
 (3) $\mu_k(mg - F \sin \theta)S$
 (4) $-\mu_k(mg - F \sin \theta)S$
9. Three forces $3(\hat{i} + 3\hat{j} + \hat{k})$, $\frac{5}{7}(-2\hat{i} + 9\hat{k})$ and $11(2\hat{i} + \hat{j} + 6\hat{k})$ are acting on a particle. Calculate the work done in displacing the particle from point $(4, -1, 1)$ to point $(11, 6, 8)$.

- (1) 756 units
 (2) 833 units
 (3) 644 units
 (4) 793 units

Answer key

Question	1	2	3	4	5	6	7	8	9
Answer	3	3	2	3	2	3	4	4	2

SOLUTIONS DPP-01

1. (3)

$$\vec{F} = (3\hat{i} + 2\hat{j}) \cdot (4\hat{i} - \hat{j} + 3\hat{k})$$

$$= 12 - 2 = 10 \text{ J}$$

2. (3)

$$\vec{d} = \vec{r}_2 - \vec{r}_1$$

$$= (\hat{i} + 2\hat{j} + \hat{k}) - (3\hat{i} + \hat{j} + 3\hat{k})$$

$$= (-2\hat{i} + \hat{j} - 2\hat{k})$$

$$W = \vec{F} \cdot \vec{d}$$

$$= (5\hat{i} + 2\hat{j} - 4\hat{k}) \cdot (-2\hat{i} + \hat{j} - 2\hat{k})$$

$$= -10 + 2 + 8 = 0$$

3. (2)

$$W_F = FS \cos \theta$$

$$= (5g) \times 2 \times \cos 0^\circ$$

$$= 5 \times 9.8 \times 2 \times 1$$

$$= 98 \text{ J}$$

4. (3)

Angle between Force and displacement is 90°
 $\therefore W = 0$

5. (2)

$W = mgH$
 independent of time

6. (3)

Block B will accelerate due to friction and gain speed therefore work by friction on block B will be positive

7. (4)

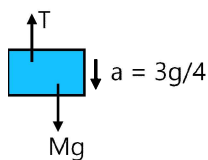

$$Mg - T = M \times \frac{3g}{4}$$

$$Mg - \frac{3Mg}{4} = T$$

$$\frac{Mg}{4} = T$$

$$W = T \times h \cos 180^\circ = -\frac{Mgh}{4}$$

8. (4)

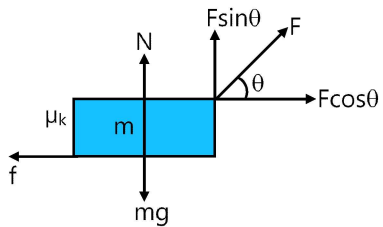

$$N = mg - F \sin \theta$$

$$f = \mu_k N$$

$$f = \mu_k (mg - F \sin \theta)$$

$$W_f = f \times S \cos 180^\circ$$

$$= -\mu_k (mg - F \sin \theta) S$$

9. (2)

Resultant of three given forces –

$$\vec{F} = \vec{F}_1 + \vec{F}_2 + \vec{F}_3$$

$$= 3\hat{i} + 9\hat{j} + 3\hat{k} + \left[-\frac{10}{7}\hat{i} + \frac{45}{7}\hat{k} \right] + [22\hat{i} + 11\hat{j} + 66\hat{k}]$$

$$= \left[\frac{165}{7}\hat{i} + 20\hat{j} + \frac{528}{7}\hat{k} \right] \text{ units}$$

$$\text{Displacement } \vec{r} = \vec{r}_2 - \vec{r}_1$$

$$= [11\hat{i} + 6\hat{j} + 8\hat{k}] - [4\hat{i} - 1\hat{j} + 1\hat{k}]$$

$$= (7\hat{i} + 7\hat{j} + 7\hat{k}) \text{ units}$$

$$\text{work done} = \vec{F} \cdot \vec{r}$$

$$= \left[\frac{165}{7}\hat{i} + 20\hat{j} + \frac{528}{7}\hat{k} \right] \cdot [7\hat{i} + 7\hat{j} + 7\hat{k}]$$

$$= 165 + 140 + 528 = 833 \text{ unit}$$

Work done by Variable Force DPP-02

1. A particle moves along the x-axis from $x = x_1$ to $x = x_2$ under the influence of a force given by $F = 2x$. Find the work done in the process.

- (1) $x_2^2 + x_1^2$
- (2) $x_2^2 - x_1^2$
- (3) $2(x_2^2 - x_1^2)$
- (4) $2(x_2^2 + x_1^2)$

2. A force $F = (10 + 0.5x)$ N acts on a particle in x direction, where x is in metres. Find the work done by this force during a displacement from $x = 0$ to $x = 2$.

- (1) 21 J
- (2) 18 J
- (3) 25 J
- (4) 15 J

3. A force F acting on an object varies with distance x as shown here. The work done by the force in moving the object from $x = 0$ to $x = 6$ m is :-

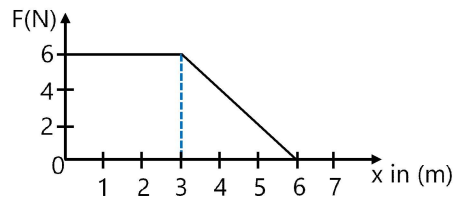

- (1) 18 J
- (2) 27 J
- (3) 36 J
- (4) 9 J

4. Calculate the work done for following F-d curves

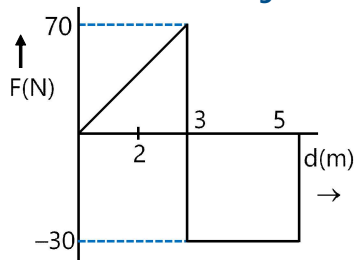

- (1) 30 J
- (2) 40 J
- (3) 45 J
- (4) 50 J

5. Calculate the work done for following F-d curves

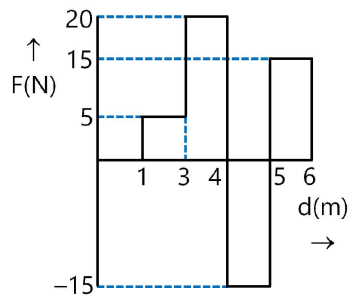

- (1) 30 J
- (2) 40 J
- (3) 45 J
- (4) 50 J

6. Calculate the work done for following F-d curves

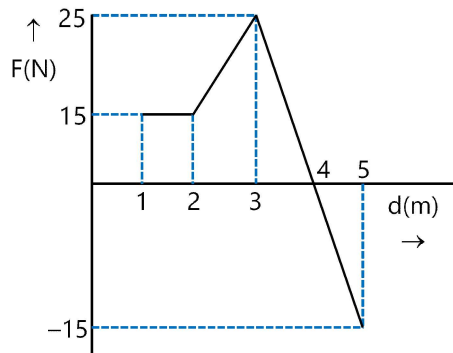

- (1) 30 J
- (2) 40 J
- (3) 45 J
- (4) 50 J

Answer key

Question	1	2	3	4	5	6
Answer	2	1	2	3	1	2

SOLUTIONS DPP-02

1. (2)

$$W = \int_{x_1}^{x_2} F dx = \int_{x_1}^{x_2} 2x dx$$

$$\Rightarrow W = x_2^2 - x_1^2$$

2. (1)

$$W = \int_0^2 F dx = \int_0^2 (10 + 0.5x) dx$$

$$\Rightarrow W = 10[x]_0^2 + 0.5 \left[\frac{x^2}{2} \right]_0^2$$

$$\Rightarrow W = 21 \text{ J}$$

3. (2)

Work done = Area under F-d curve

4. (3)

Work done = Area under F-d curve

5. (1)

Work done = Area under F-d curve

6. (2)

Work done = Area under F-d curve

Energy DPP-03

1. **If the kinetic energy of a body becomes 4 times of its initial kinetic energy, then the momentum of the body will become :-**

- (1) $2\sqrt{2}$ times
- (2) $\sqrt{2}$ times
- (3) 2 times
- (4) none of these

2. **2 particles of mass 3 Kg and 5 kg have same momentum, calculate ratio of their K.E.**

- (1) 5 : 3
- (2) 3 : 5
- (3) 25 : 9
- (4) 9 : 25

3. **If the kinetic energy of a body is increased by 800%, the momentum will increase by :-**

- (1) 100%
- (2) 200%
- (3) 150%
- (4) 300%

4. **If the kinetic energy of a body increases by 2% then momentum :**

- (1) increases by 2%
- (2) increases by 1%
- (3) increases by 8%
- (4) increases by 16%

5. **The graph between kinetic energy E_k and velocity V is –**

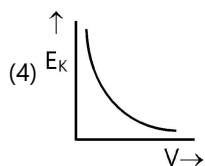
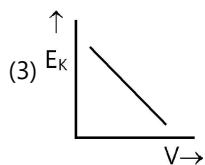
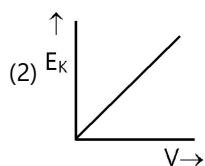
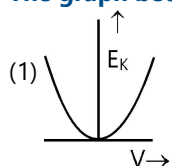

Answer key

Question	1	2	3	4	5
Answer	3	1	2	2	1

SOLUTIONS DPP-03

1. (3)

$$KE \propto P^2$$

$$\frac{P_1}{P_2} = \sqrt{\frac{K_1}{K_2}}$$

$$P_2 = 2P_1$$

2. (1)

$$P = \text{constant}$$

$$\text{So } K \propto \frac{1}{m}$$

$$K_1 : K_2 \Rightarrow m_2 : m_1 \\ = 5 : 3$$

3. (2)

$$\frac{P_1}{P_2} = \sqrt{\frac{K_1}{K_2}}$$

$$P_2 = 3P_1$$

\therefore Momentum P_2 increased by 200%

4. (2)

$$\frac{\Delta KE}{KE} = \frac{2\Delta P}{P}$$

$$2\% = \frac{2\Delta P}{P}\%$$

$$\frac{\Delta P}{P}\% = 1\%$$

5. (1)

$$E_k = \frac{1}{2}mv^2 \therefore \text{Graph is parabola}$$

Problems based on Work Energy Theorem DPP-04

- A force is acted upon a body of mass 6 kg which causes in its displacement which is given as $S = \frac{t^3}{4}$ metres where 't' is time. The work done by the force in 2 seconds is :-

 - 18 J
 - 9 J
 - 27 J
 - 16 J
- A force acts on a 20 g particle in such a way that the position of the particle as a function of time is given by $x = 2t - 3t^2 + 2t^3$, where x is in metres and t is in seconds. The work done during the first 3 second is :-

 - 5.28 J
 - 28.8 J
 - 14.4 J
 - 7.2 J
- A 2 kg ball is thrown up with an initial speed 12 m/s and reaches a maximum height of 10 m. How much energy is dissipated by air drag acting on the ball during the ascent ?

 - 40 J
 - 56 J
 - 36 J
 - 72 J
- A block weighing 10 N travels down a smooth curved track AB joined to a rough horizontal surface. The rough surface has a friction coefficient of 0.20 with the block. If the block starts slipping on the track from a point 1.0 m above the horizontal surface, then it would move a distance S on the rough surface. Calculate the value of S [g = 10 m/s²]

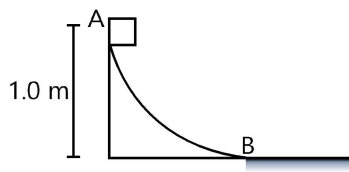

- 10 m
- 5 m
- 8 m
- 16 m

5. A particle moves on a rough horizontal ground with some initial velocity say v_0 . If $\frac{3}{4}$ of its kinetic energy is lost due to friction in time t_0 then coefficient of friction between the particle and the ground is :-

(1) $\frac{v_0}{2gt_0}$

(2) $\frac{v_0}{4gt_0}$

(3) $\frac{3v_0}{4gt_0}$

(4) $\frac{v_0}{gt_0}$

6.

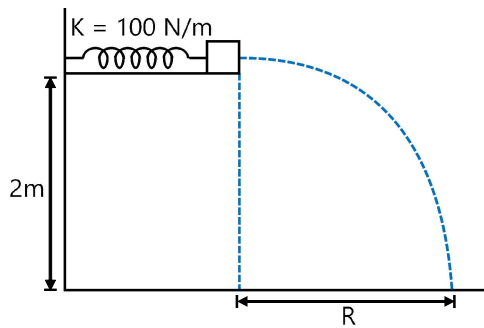

A small block of mass 100 g is pressed against a horizontal spring fixed at one end to compress spring through 5 cm . When released, the block moves horizontally till it leaves the spring. Find value of R .

(1) 1 m

(2) $\sqrt{2}\text{m}$

(3) 2 m

(4) $\frac{1}{\sqrt{2}}\text{m}$

Answer key

Question	1	2	3	4	5	6
Answer	3	3	2	2	1	1

SOLUTIONS DPP-04

1. (3)

$$s = \frac{t^3}{4}$$

$$v = \frac{3t^2}{4}$$

at $t = 0$, $v = 0$

at $t = 2\text{sec}$, $v = \frac{3(2)^2}{4} = 3 \text{ m/s}$

By W.E.T.

$$W = \Delta KE$$

$$W = \frac{1}{2} 6 \times 3^2 - \frac{1}{2} 6 \times 0^2$$

$$W = 27 \text{ J}$$

2. (3)

$$x = 2t - 3t^2 + 2t^3$$

$$v = 2 - 6t + 6t^2$$

$$W = \Delta KE$$

$$t = 0 \Rightarrow v_1 = 2$$

$$t = 3 \Rightarrow v_2 = 38$$

$$KE = \frac{1}{2} \times \frac{20}{1000} [1444 - 4]$$

$$KE = \frac{1440}{100} = 14.40$$

3. (2)

$$E = -\frac{1}{2}mv^2 + mgh$$

$$= -\frac{1}{2} \times 2 \times 144 + 2 \times 10 \times 10$$

$$= -144 + 200 = 56 \text{ J}$$

4. (2)

$$W_C + W_{nc} + W_{ext} = \Delta K$$

$$mgh - f.s + 0 = 0 \Rightarrow mgh - \mu mg.s = 0$$

$$\Rightarrow s = \frac{h}{\mu} = \frac{1}{0.2} = 5\text{m}$$

5. (1)

$$K_f = \frac{1}{4} K_i \Rightarrow v_f = \frac{v_0}{2}$$

$$a = \mu g \quad [\text{as } f = \mu mg]$$

$$\text{So } \frac{v_0}{2} = v_0 - \mu g t_0 \Rightarrow \mu = \frac{v_0}{2gt_0}$$

6. (1)

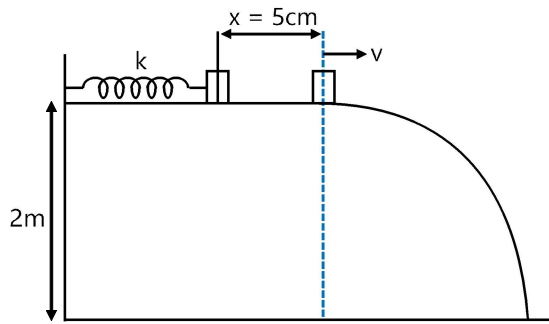

$$\frac{1}{2} kx^2 = \frac{1}{2} mv^2$$

$$100 \times \left(\frac{5}{100} \right)^2 = \frac{100}{1000} \times v^2$$

$$100 \times \frac{25}{10000} = \frac{v^2}{10}$$

$$v^2 = 2.5 \Rightarrow v = \sqrt{2.5}$$

$$T = \sqrt{\frac{2H}{g}} = \sqrt{\frac{2 \times 2}{10}} = \sqrt{0.4}$$

$$R = vT = \sqrt{2.5 \times 0.4} = 1$$

Gravitational and Spring Potential Energy DPP-05

1. Which of the following statements is not true for work done by conservative forces :-

- (1) It does not depend on path
- (2) It is equal to the difference of initial and final potential energy function
- (3) It can be recovered completely
- (4) None of the above

2. As shown in the diagram a particle is to be carried from point A to C via paths (I), (II) and (III) in gravitational field, then which of the following statements is correct :-

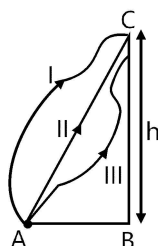

- (1) Work done is same for all the paths
- (2) Work done is minimum for path (II)
- (3) Work done is maximum for path (I)
- (4) None of the above

3. Which of the following is a non conservative force:-

- (1) Electric force
- (2) Gravitational force
- (3) Spring force
- (4) Viscous force

4. A 10 kg satellite completes one revolution around the earth at a height of 100 km in 108 minutes. The work done by the gravitational force of earth will be –

- (1) $108 \times 100 \times 10$ J
- (2) $\frac{108 \times 10}{100}$ J
- (3) 0 J
- (4) $\frac{100 \times 10}{108}$ J

5. For the path PQR in a conservative force field the amounts of work done in carrying a body from P to Q and from Q to R are 15 Joule and 5 Joule respectively. The work done in carrying the body from P to R will be –

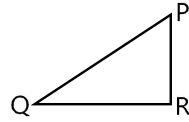

- (1) 20 J
 (2) 10 J
 (3) 5 J
 (4) Zero
6. A body of mass 3 kg falls from a height of 20 m. What is the loss in potential energy :-
 (1) 400 J
 (2) 300 J
 (3) 200 J
 (4) 600 J
7. A uniform chain of length L and mass M is lying on a smooth table and $\frac{1}{3}$ rd of its length is hanging down over the edge of the table. If g is the acceleration due to gravity, the work done to pull the hanging part on the table is :-
 (1) MgL
 (2) $\frac{MgL}{18}$
 (3) $\frac{MgL}{9}$
 (4) $\frac{2MgL}{9}$
8. A brick has 3 sides a, b, c {a > b > c}. The brick can be kept on ground on any face. The work required to be done to move slowly from minimum potential energy situation to maximum potential energy situation of brick is :

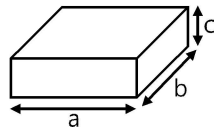

- (1) $mg\left(\frac{a}{2} - \frac{b}{2}\right)$
 (2) $mg\left(\frac{a}{2} - \frac{c}{2}\right)$
 (3) $mg\left(\frac{b}{2} - \frac{c}{2}\right)$
 (4) $mg\left(\frac{a+c}{2} - \frac{b}{2}\right)$

9. A spring of force constant 1000 N/m has an extension of 15 cm. The work done in extending it from 15 cm to 25 cm is :-
- (1) 16 J
 - (2) 8 J
 - (3) 32 J
 - (4) 20 J
10. In stretching a spring by 5 cm energy stored is given by U, then the energy stored if the spring is stretched by 10 cm will be :-
- (1) U
 - (2) 5U
 - (3) 4U
 - (4) 25U
11. A weight W suspended from a spring is raised through a height h so that the spring becomes just slack. If E was the energy of the stretched spring, then the gain in gravitational potential energy is
- (1) Wh
 - (2) Wh + E
 - (3) Wh - E
 - (4) E
12. A long spring is stretched by 2 cm; its potential energy is U. If the spring is stretched by 10 cm, the potential energy stored in it will be :
- (1) $\frac{U}{25}$
 - (2) $\frac{U}{2}$
 - (3) 5U
 - (4) 25U
13. The potential energy of a spring when stretched through a distance x is 10 J. What is the amount of work done on the same spring to stretch it through an additional distance x ?
- (1) 10 J
 - (2) 20 J
 - (3) 30 J
 - (4) 40 J
14. The work done by external agent in stretching a spring of force constant k from length l_1 to l_2 is
- (1) $\frac{k}{2}(l_2^2 - l_1^2)$
 - (2) $\frac{k}{2}(l_1 + l_2)^2$
 - (3) $\frac{k}{2}[(l_1 + l_2)^2 - l_1^2]$
 - (4) None

Answer key

Question	1	2	3	4	5	6	7	8	9	10	11	12	13	14
Answer	4	1	4	3	1	4	2	2	4	3	2	4	3	1

SOLUTIONS DPP-05

1. (4)

Work done by a conservative force is independent of the path

$$W_C = -\Delta U = U_i - U_f$$

2. (1)

Gravitation is conservative force, work done is path independent

3. (4)

Viscous force = fluid friction = non-conservative force

4. (3)

Here gravitation force of earth is centripetal force $\theta = 90^\circ$, Work done = 0

5. (1)

$$W_{PQ} + W_{QR} + W_{RP} = 0$$

$$15 + 5 + W_{RP} = 0$$

$$W_{RP} = -20 \text{ J}$$

6. (4)

$$W = -\Delta U$$

$$W = mgh$$

$$= 3 \times 10 \times 20 = 600 \text{ J}$$

7. (2)

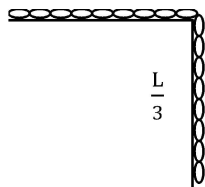

$$W = mgh$$

$$m = \frac{M}{L} \times \left(\frac{L}{3}\right) = \frac{M}{3}$$

$$h = \left(\frac{L}{3}\right) \times \frac{1}{2} = \frac{L}{6} \text{ (By COM)}$$

$$WD = \frac{M}{3} \times \frac{L}{6} \times g = \frac{MgL}{18}$$

8. (2)

$$W' = \Delta U = U_{\max} - U_{\min} = mg \left(\frac{a}{2} - \frac{c}{2} \right)$$

9. (4)

$$\begin{aligned} W &= \frac{1}{2}k(x_2^2 - x_1^2) \\ &= \frac{1}{2} \times \frac{1000}{10^4} (25^2 - 15^2) \\ &= \frac{1}{2} \times \frac{1}{10} [625 - 225] \\ &= \frac{1}{2} \times \frac{1}{10} \times 400 = 20 \text{ J} \end{aligned}$$

10. (3)

$$\begin{aligned} \frac{1}{2}K(5)^2 &= U \\ \frac{1}{2}K(10)^2 &= U' \\ \frac{U}{U'} &= \frac{5^2}{10^2} = \frac{25}{100} = \frac{1}{4} \\ U' &= 4U \end{aligned}$$

11. (2)

Both the elastic potential energy and the work done are stored as gravitational potential energy.

12. (4)

$$KE \propto x^2$$

13. (3)

Potential energy of the spring when stretched through a distance x ,

$$U = \frac{1}{2}kx^2 = 10 \text{ J}$$

When x becomes $2x$, the potential energy will be

$$U' = \frac{1}{2}k(2x)^2 = 4 \times \frac{1}{2}kx^2 = 4 \times 10 = 40 \text{ J}$$

$$\therefore \text{Work done} = U' - U = 40 - 10 = 30 \text{ J}$$

14. (1)

$$U_2 = \frac{1}{2}kl_2^2$$

$$U_1 = \frac{1}{2}kl_1^2$$

$$W = U_2 - U_1$$

$$= \frac{1}{2}kl_2^2 - \frac{1}{2}kl_1^2 = \frac{1}{2}k(l_2^2 - l_1^2)$$

Types of Equilibrium DPP-06

1. Figure shows a plot of the potential energy as a function of x for a particle moving along the x -axis:-

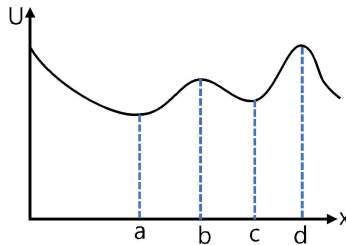

Which of the following statement(s) is/are true?

- (1) a, c, and d are points of equilibrium
- (2) a is a point of stable equilibrium
- (3) b is a unstable equilibrium point
- (4) All of the above

2. The graph between potential energy U and displacement X in the state of stable equilibrium will be-

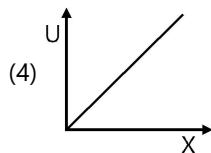
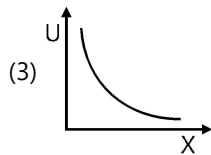
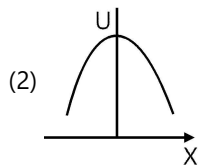
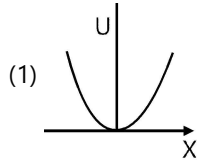

3. A particle moves in a potential region given by $U = 2x^2 - 2x + 100$ J. Its state of equilibrium will be-

- (1) $x = 25$ m
- (2) $x = 0.25$ m
- (3) $x = 0.05$ m
- (4) $x = 0.5$ m

4. If the potential energy of system of two molecules is given by, $U = \frac{A}{r^{12}} - \frac{B}{r^6}$ then at equilibrium position, its potential energy is equal to :

- (1) $\frac{A^2}{4B}$
- (2) $-\frac{B^2}{4A}$
- (3) $\frac{2B}{A}$
- (4) $3A$

5. A particle moves in one dimensional field with total mechanical energy E. If its potential energy is U(x), then

- (1) particle has zero speed where $U(x) = 0$
- (2) particle has zero acceleration where $U(x) = E$
- (3) particle has zero velocity where $\frac{dU(x)}{dx} = 0$
- (4) particle has zero acceleration where $\frac{dU(x)}{dx} = 0$

6. The force acting on a body moving along x-axis varies with the position of the particle as shown in the figure.

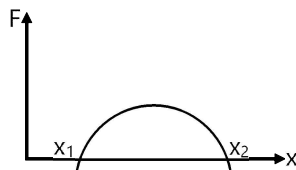

The body is in stable equilibrium at

- (1) $x = x_1$
- (2) $x = x_2$
- (3) both x_1 and x_2
- (4) neither x_1 nor x_2

Answer key

Question	1	2	3	4	5	6
Answer	4	1	4	2	4	2

SOLUTIONS DPP-06

1. (4)

For equilibrium $\frac{dU}{dx} = 0$ Pt a, b, c, d

For stable equilibrium $\frac{d^2U}{dx^2} > 0$ Pt a, c

For unstable equilibrium $\frac{d^2U}{dx^2} < 0$ Pt b, d

2. (1)

For stable equilibrium

$$F = 0$$

$$\frac{dF}{dx} < 0$$

3. (4)

$$F = -\frac{dU}{dx}$$

For equilibrium $\frac{dU}{dx} = 0$

$$4x - 2 = 0$$

$$x = \frac{2}{4} = 0.5$$

4. (2)

$$U = \frac{A}{r^{12}} - \frac{B}{r^6}$$

$\frac{dU}{dr} = 0$ at Equilibrium

$$\therefore \frac{-12A}{r^{13}} - \frac{(-6)B}{r^7} = 0; \frac{6}{r^7} \left[\frac{-2A}{r^6} + B \right] = 0$$

$$r = \left(\frac{2A}{B} \right)^{1/6}$$

\therefore At equilibrium U is given by

$$U = \frac{A}{\left(\frac{2A}{B} \right)^2} - \frac{B}{\frac{2A}{B}} = \frac{B^2}{4A} - \frac{B^2}{2A} = -\frac{B^2}{4A}$$

5. (4)

Mechanical energy = kinetic energy + potential energy

$$E = K + U(x) \text{ where } K = \frac{1}{2}mv^2$$

If $K = 0$ then $E = U(x)$

$$\text{If } F = 0 \text{ then } F = -\frac{dU(x)}{dx} = 0 \Rightarrow \frac{dU(x)}{dx} = 0$$

6. (2)

When particle moves away from the origin then at position $x = x_1$ force is zero and at $x > x_1$ force is positive (repulsive in nature) so particle moves further and does not return back to original position.

i.e. the equilibrium is not stable.

Similarly at position $x = x_2$ force is zero and at $x > x_2$, force is negative (attractive in nature)

So particle return back to original position i.e., the equilibrium is stable.

Conservation of Mechanical Energy DPP-07

- 1. A body is dropped from a height h . When loss in its potential energy is U then its velocity is v . The mass of the body is –**

 - (1) $\frac{U^2}{2v}$
 - (2) $\frac{2v}{U}$
 - (3) $\frac{2v}{U^2}$
 - (4) $\frac{2U}{v^2}$
- 2. A block of mass 4 kg is moving on a frictionless horizontal surface with velocity 2m/s and comes to rest after pressing a spring. If the force constant of the spring is 100 N/m then the compression in the spring will be –**

 - (1) 0.8 m
 - (2) 1.6 m
 - (3) 0.4 m
 - (4) 3.2 m
- 3. A ball of mass 2 kg is released from the tower of Pisa. The kinetic energy generated in it after falling through 10m will be –**

 - (1) 20 J
 - (2) 196 J
 - (3) 49 J
 - (4) 98 J
- 4. A projectile is fired at 30° with momentum p , neglecting friction, the change in kinetic energy, when it returns back to the ground, will be :-**

 - (1) zero
 - (2) 30 %
 - (3) 60 %
 - (4) 100 %
- 5. A heavy weight is suspended from a spring. A person raises the weight till the spring becomes slack. The work done by him is W . The energy stored in the stretched spring was E . What will be the gain in gravitational potential energy ?**

 - (1) W
 - (2) E
 - (3) $W + E$
 - (4) $W - E$

6. **An athlete jumping vertically on a trampoline leaves the surface with a velocity of 10 m/s upward. What maximum height does she reach ?**
- (1) 10 m
 - (2) 2.5 m
 - (3) 5.0 m
 - (4) 0.50 m
7. **The force constant of a weightless spring is 16 N m^{-1} . A body of mass 1.0 kg suspended from it is pulled down through 5 cm and then released. The maximum kinetic energy of the system (spring + body) will be**
- (1) $2 \times 10^{-2} \text{ J}$
 - (2) $4 \times 10^{-2} \text{ J}$
 - (3) $8 \times 10^{-2} \text{ J}$
 - (4) $16 \times 10^{-2} \text{ J}$
8. **A raindrop of mass 1 g falling from a height of 1 km hits the ground with a speed of 50 m s^{-1} . Which of the following statements is correct ? (Take $g = 10 \text{ m s}^{-2}$)**
- (1) The loss of potential energy of the drop is 10 J.
 - (2) The gain in kinetic energy of the drop is 1.25 J.
 - (3) The gain in kinetic energy of the drop is not equal to the loss of potential energy of the drop.
 - (4) All of these.

Answer key

Question	1	2	3	4	5	6	7	8
Answer	4	3	2	1	3	3	1	4

SOLUTIONS DPP-07

1. (4)

$$U = \frac{1}{2}mv^2$$

$$\therefore m = \frac{2U}{v^2}$$

2. (3)

By COME

$$\frac{1}{2}mv^2 = \frac{1}{2}kx^2$$

$$4 \times (2)^2 = 100 \times x^2$$

$$\frac{4 \times 4}{100} = x^2$$

$$\Rightarrow \frac{16}{100} = x^2$$

$$x = 0.4 \text{ m}$$

3. (2)

$$W = mgh = 2 \times 9.8 \times 10 = 196 \text{ J}$$

4. (1)

In projectile motion, there is no change in kinetic energy of projectile while landing to the ground and projected from ground. Because speed is same at the time of projection and striking.

5. (3)

Total gravitational energy gained

= work done + energy released by the spring

$$= W + E$$

6. (3)

Using energy conservation

$$mgy_{\max} = \frac{1}{2}mv_i^2$$

$$y_{\max} = \frac{v_i^2}{2g}$$

$$y_{\max} = \frac{v_i^2}{2g} = \frac{(10.0 \text{ m/s})^2}{2(10.0 \text{ m/s}^2)} = 5.0 \text{ m}$$

7. (1)

Maximum kinetic energy = Maximum elastic potential energy.

$$\begin{aligned} &= \frac{1}{2} \times 16 \left(\frac{5}{100} \right)^2 \text{ J} \\ &= \frac{8 \times 25}{100 \times 100} \text{ J} = 2 \times 10^{-2} \text{ J} \end{aligned}$$

8. (4)

(1) The loss of potential energy of the drop = $mgh = (10^{-3}) (10) (1000) = 10 \text{ J}$

(2) The gain in kinetic energy of the drop = $\frac{1}{2}mv^2 = (10^{-3}) (50)^2 = 1.25 \text{ J}$

(3) Here we can see the gain in kinetic energy of the drop is not equal to the loss of potential energy of the drop.

Problems based on Power DPP-08

- 1. An electric motor produces a tension of 5000N in a load lifting cable and rolls it at the rate of 2 m/s. The power of the motor is –**

 - (1) 10 kw
 - (2) 15 kw
 - (3) 25 kw
 - (4) 9×10^3 hp
- 2. A car of 50 Hp motor is moving with a constant velocity of 36 km/hour. The forward force exerted by the engine on the car is – (1 hp = 746 W)**

 - (1) 3.73×10^3 N
 - (2) 3.73×10^2 N
 - (3) 3.73×10^1 N
 - (4) None of the above
- 3. A crane lifts 200 kg weight from earth's surface upto a height of 3m in 4 seconds. The average power generated by it will be – ($g = 9.8 \text{ m/sec}^2$)**

 - (1) 1470 W
 - (2) 735 W
 - (3) 2940 W
 - (4) 0 W
- 4. What average horsepower is developed by a 50 kg man while climbing stairs of height that rises 10 m vertically in 10s ?**

 - (1) 0.66 Hp
 - (2) 1.26 Hp
 - (3) 1.8 Hp
 - (4) 2.1 Hp
- 5. A 2.0 Hp motor pumps out water from a well of depth 8 m and fills a water tank of volume 1492 liters at a height of 16 m from the ground. The running time of the motor to fill the empty water tank is ($g = 10\text{m/s}^2$)**

 - (1) 50 minutes
 - (2) 10 minutes
 - (3) 4 minutes
 - (4) 20 minutes

6. **Water is falling on the blades of a turbine at a rate of 50 kg/s from a certain spring. If the height of the spring be 50 metres, the power transferred to the turbine will be :-**
- (1) 100 KW
 - (2) 25 KW
 - (3) 5 KW
 - (4) 250 KW
7. **A time varying power $P = 2t$ is applied on a particle of mass 3kg. The change in kinetic energy of the particle at $t = 4$ sec is :-**
- (1) 4 J
 - (2) 8 J
 - (3) 16 J
 - (4) 24 J
8. **A body of mass m starting from rest from origin moves along x -axis with constant power (P). Calculate relation between velocity and distance :-**
- (1) $x \propto v^{1/2}$
 - (2) $x \propto v^2$
 - (3) $x \propto v$
 - (4) $x \propto v^3$
9. **A body of mass m accelerates uniformly from rest to velocity v_1 in time t_1 . The instantaneous power delivered to the body as a function of time t is-**
- (1) $\frac{mv_1 t}{t_1}$
 - (2) $\frac{mv_1^2 t}{t_1^2}$
 - (3) $\frac{mv_1 t^2}{t_1}$
 - (4) $\frac{mv_1^2 t}{t_1}$

Answer key

Question	1	2	3	4	5	6	7	8	9
Answer	1	1	1	1	3	2	3	4	2

SOLUTIONS DPP-08

1. (1)

$$P = \vec{F} \cdot \vec{v}$$

$$= 5000 \times 2 = 10 \text{ KW}$$

2. (1)

$$F = \frac{P}{v} = \frac{50 \times 746}{36 \times \frac{5}{18}} = 3.73 \times 10^3 \text{ N}$$

3. (1)

$$P_{\text{avg}} = \frac{W}{t} = \frac{mgh}{t} = \frac{200 \times 9.8 \times 3}{4} = 1470$$

4. (1)

$$P = \frac{mgh}{t}$$

$$= \frac{50 \times 10 \times 10}{10}$$

$$P = \frac{500}{746} = 0.66 \text{ hp}$$

5. (3)

Mass of water

$$= 1492 \times 10^{-3} \times 10^3 = 1492 \text{ kg}$$

Energy = mgh

$$= 1492 \times 10 (16 + 8)$$

$$P = \frac{\text{Energy}}{\text{Time}}$$

$$2 \times 746 = \frac{1492 \times 10 \times 24}{t}$$

$$t = 240 \text{ sec} = 4 \text{ minutes}$$

6. (2)

$$P = \frac{mgh}{t}$$

$$= 50 \times 10 \times 50$$

$$= 25 \text{ kW}$$

7. (3)

$$P = \frac{dK}{dt} = 2t$$

$$\int_{K_i}^{K_f} dK = \int_0^4 2t dt$$

$$\Delta K = [t^2]_0^4 = 16 \text{ J}$$

8. (4)

$$P = mav \Rightarrow P = m \left(v \frac{dv}{dx} \right) \cdot v$$

$$\Rightarrow mv^2 dv = P dx$$

$$\Rightarrow \frac{mv^3}{3} = Px \Rightarrow v \propto x^{1/3}$$

9. (2)

$$P = F \cdot v = ma \cdot v$$

$$a = \frac{v_1}{t_1} \text{ \& } v = 0 + \frac{v_1}{t_1} t$$

$$\text{So } P = m \left(\frac{v_1}{t_1} \right) \left(\frac{v_1}{t_1} t \right) \Rightarrow P = \frac{mv_1^2}{t_1} t$$