



# GGSRDN

Educational Services Private Limited

9<sup>th</sup>, 10<sup>th</sup>, NEET, JEE(Main/Advanced)

अभ्यास ही सबसे बड़ा गुरु है।

## CLASS : XII (PHYSICS)

# D P P P

## DAILY PRACTICE PROBLEM

### DPP- 41 to 60

- DPP 41 : Circular Motion, Rigid Body Dynamics, Surface Tension, Geometrical Optics, Gravitation
- DPP 42 : Gravitation, Elasticity & Viscosity, Geometrical Optics, Sound Wave, Rigid Body Dynamics, Current Electricity
- DPP 43 : Current Electricity, Elasticity & Viscosity, Geometrical Optics, Gravitation, Sound Wave, Rigid Body Dynamics
- DPP 44 : Circular Motion, Relative Motion, Rectilinear Motion, Gravitation, Electrostatics, Geometrical Optics
- DPP 45 : Rectilinear Motion, Relative Motion, Circular Motion, Sound Wave, Electrostatics
- DPP 46 : Electrostatics, Rectilinear Motion, Relative Motion, Simple Harmonic Motion
- DPP 47 : Rectilinear Motion, Friction, Circular Motion, Gravitation, Relative Motion, Electrostatics
- DPP 48 : Electrostatics, Friction, Circular Motion, Current Electricity
- DPP 49 : Electrostatics, Kinematics, Current Electricity, Center of Mass, Newton's Law of Motion
- DPP 50 : Current Electricity, Capacitance, Sound Wave, Kinematics
- DPP 51 : Current Electricity, Capacitance, Sound, Electrostatics
- DPP 52 : Current Electricity, Sound, Fluids, Capacitor, Rotation
- DPP 53 : Rotation, Capacitor, Center of Mass, Gravitation, Current Electricity, Electrostatics

DPP 54 : **Center of Mass, Rotation, Current Electricity, Capacitor, Gravitation, Electrostatics**

DPP 55 : **Electrostatics, Current Electricity, Capacitor, Gravitation, Rotation, Center of Mass**

DPP 56 : **Current Electricity, Heat, Kinematics, Simple Harmonic Motion, Capacitance**

DPP 57 : **Heat, Simple Harmonic Motion, Current Electricity, Kinematics, Capacitance**

DPP 58 : **Heat, Kinematics, Simple Harmonic Motion, Viscosity, Elasticity, Capacitance, Current Electricity**

DPP 59 : **Elasticity, Work, Power and Energy, Rotation, Heat, Current Electricity**

DPP 60 : **Heat, Work, Power and Energy, Rotation, Elasticity, Current Electricity**

GGSRDN  
NEET, JEE(MAIN + ADVANCED)



4. A tube of length  $\ell$  open at only one end is cut into two equal halves. The sixth overtone frequency of piece closed at one end equals to sixth overtone frequency of piece open at both ends. The radius of cross-section of tube is :
- (A)  $\frac{\ell}{12}$                       (B)  $\frac{5\ell}{72}$                       (C)  $\frac{\ell}{24}$                       (D)  $\frac{5\ell}{24}$
- (E)  $\frac{5\ell}{48}$
5. A ray of light is incident from air to a glass rod at point A the angle of incidence being  $45^\circ$ . The minimum value of refractive index of the material of the rod so that T.I.R. takes place at B is \_\_\_\_\_.

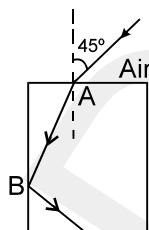

**COMPREHENSION**

Consider a star and two planet system. The star has mass  $M$ . The planet A and B have the same mass  $m$ , radius  $a$  and they revolve around the star in circular orbits of radius  $r$  and  $4r$  respectively ( $M \gg m$ ,  $r \gg a$ ). Planet A has intelligent life, and the people of this planet have achieved a very high degree of technological advance. They wish to shift a geostationary satellite of their own planet to a geostationary orbit of planet B. They achieve this through a series of high precision maneuvers in which the satellite never has to apply brakes and not a single joule of energy is wasted.  $S_1$  is a geostationary satellite of planet A and  $S_2$  is a geostationary satellite of planet B. Neglect interaction between A and B,  $S_1$  and  $S_2$ ,  $S_1$  and B &  $S_2$  and A.

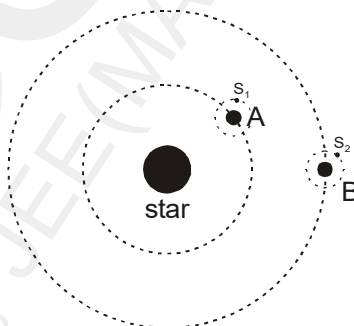

6. If the time period of the satellite in geostationary orbit of planet A is  $T$ , then its time period in geostationary orbit of planet B is :
- (A)  $T$                       (B)  $4T$                       (C)  $8T$                       (D) Data insufficient
7. If the radius of the geostationary orbit in planet A is given by  $r_G = r \left( \frac{m}{M} \right)^{1/3}$ , then the time in which the geostationary satellite will complete 1 revolution is
- I. 1 planet year = time in which planet revolves around the star  
 II. 1 planet day = time in which planet revolves about its axis.
- (A) I                      (B) II                      (C) both I and II                      (D) neither I nor II.
8. If planet A and B, both complete one revolution about their own axis in the same time, then the energy needed to transfer the satellite of mass  $m_0$  from planet A to planet B is.
- (A)  $\frac{Gmm_0}{4r}$                       (B)  $\frac{GMm_0}{4r}$                       (C)  $\frac{3GMm_0}{8r}$                       (D) Zero

**Topics : Gravitation, Elasticity & Viscosity, Geometrical Optics, Sound Wave, Rigid Body Dynamics, Current Electricity**

**Type of Questions**

Single choice Objective ('-1' negative marking) Q.1 to Q.2	(12 marks, 12 min.)	M.M., Min. [6, 6]
Subjective Questions ('-1' negative marking) Q.3 to Q.5	(4 marks, 5 min.)	[12, 15]
Comprehension ('-1' negative marking) Q.6 to Q.8	(3 marks, 3 min.)	[9, 9]

- In a binary star system one star has thrice the mass of other. The stars rotate about their common centre of mass then:
  - Both stars have same angular momentum about common centre of mass.
  - Both stars have angular momentum of same magnitude about common centre of mass.
  - Both stars have same angular speeds.
  - Both stars have same linear speeds.
- A thin rod of negligible mass and area of cross-section  $2 \times 10^{-6} \text{ m}^2$ , suspended vertically from one end, has a length of 0.5 m at  $200^\circ\text{C}$ . The rod is cooled to  $0^\circ\text{C}$ , but prevented from contracting by attaching a mass at the lower end. The value of this mass is : (Young's modulus =  $10^{11} \text{ N/m}^2$ , Coefficient of linear expansion  $10^{-5} \text{ K}^{-1}$  and  $g = 10 \text{ m/s}^2$ ):
 

(A) 20 kg                      (B) 30 kg                      (C) 40 kg                      (D) 50 kg
- A glass sphere with 10 cm radius has a 5 cm radius concentric spherical hole. A narrow beam of parallel light from outside is incident on the sphere. Find the final image position with respect to the last surface. The refractive index of the glass is 1.5.

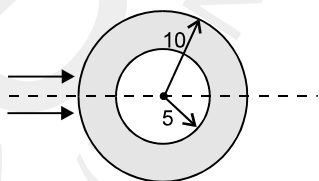

- A sound wave propagating along x-axis, in medium I of density  $\rho_1 = 1.5 \text{ kg/m}^3$  is transmitted to a medium II of density  $\rho_2 = 3 \text{ kg/m}^3$  as shown. The equation of excess pressure developed by wave in medium I and that in medium II respectively are

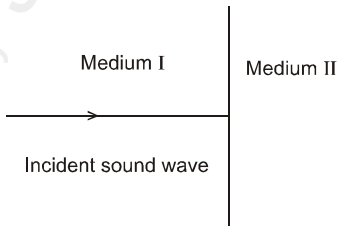

$$p_1 = 4 \times 10^{-2} \cos \omega \left( t - \frac{x}{400} \right) \quad (\text{in SI units})$$

$$p_2 = 3 \times 10^{-2} \cos \omega \left( t - \frac{x}{1200} \right) \quad (\text{in SI units})$$

If the intensity of transmitted wave is  $I_2$  (wave in medium II) and intensity of incident wave is  $I_1$  (wave in medium I), then find the value of  $\frac{6I_1}{I_2}$ .

5. A uniform thin rod of mass 'm' and length '3ℓ' is released from rest from horizontal position as shown. When it passes through the vertical line AD, it gets broken at point 'C' due to some reason. Find the angle (in radian) rotated by rod BC till its centre of mass passes through the horizontal line PQ from the instant of breakage. ( $g = 10 \text{ m/s}^2$ ) (hinge is smooth)

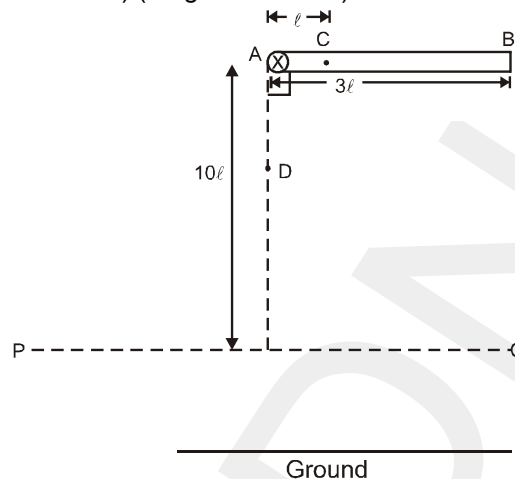

**COMPREHENSION**

Consider a battery with a large internal resistance ( $r \rightarrow \infty$ )  $\approx 10 \text{ k}\Omega$ . If we connect a light resistance  $R$  ( $R \ll r$ ) across it, current will be

$$\frac{E}{r+R} \approx \frac{E}{r} = \text{constant (Independent from external resistance } R)$$

So if we put any light resistance across it, current in it would not change, and will be constant ( $\approx \frac{E}{r}$ )

So a battery with a large internal resistance is equivalent to a constant current source (A source providing a constant current)

This concept is used in potentiometer circuit for comparing two resistances  $R$  and  $X$ , as shown in figure.

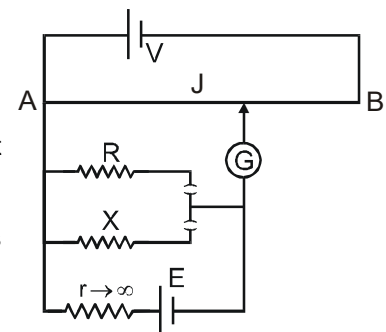
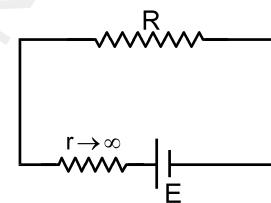

Here a battery with large internal resistance supply a constant current ( $i$ ) to either  $R$  or  $X$ . If it is connected to  $R = 10 \Omega$  potential drop across it will be  $iR$ , and the balance length is found to be 58.3 cm. If it is connected to  $X$  (unknown), Potential drop across it will be  $iX$  and the balance length is coming = 68.5 cm.

6. Estimate the unknown resistance  $X$   
 (A) 11.25                      (B) 11.75                      (C) 12.25                      (D) 12.50
7. If you fail to find any balanced point, as we slide the jockey along  $AB$ . What may be the reason.  
 (A) Resistance of potentiometer wire may be large.  
 (B) Emf of the primary cell ( $V$ ) may be very high  
 (C) potential drop across  $R$  or  $X$  may exceed  $V$   
 (D) Emf of the source ( $E$ ), may be very large.
8. In the previous question, what can we do to get the balance point  
 (A) Increase  $V$   
 (B) Reduce  $E$   
 (C) Increase the internal resistance ( $r$ ) connected with  $E$   
 (D) Use a longer potentiometer wire

**Topics : Current Electricity, Elasticity & Viscosity, Geometrical Optics, Gravitation, Sound Wave, Rigid Body Dynamics**

**Type of Questions**

		<b>M.M., Min.</b>
Single choice Objective ('-1' negative marking) Q.1 to Q.2	(3 marks, 3 min.)	[6, 6]
Multiple choice objective ('-1' negative marking) Q.3	(4 marks, 4 min.)	[4, 4]
Subjective Questions ('-1' negative marking) Q.4 to Q.5	(4 marks, 5 min.)	[4, 5]
Comprehension ('-1' negative marking) Q.6 to Q.8	(3 marks, 3 min.)	[9, 9]

1. In the given circuit all resistors are of R ohm each. If a wire is connected between C and B, then the ratio of equivalent resistance between AB of original circuit to new circuit formed is:

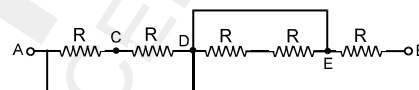

- (A) 1 (B) 3 (C) 1/3 (D) 1/2

2. A sphere of mass m and radius r is projected in a gravity free space with speed v. If coefficient of viscosity is  $\frac{1}{6\pi}$ , the distance travelled by the body before it stops is :

- (A)  $\frac{mv}{2r}$  (B)  $\frac{2mv}{r}$  (C)  $\frac{mv}{r}$  (D) none of these

3. An object AB is placed parallel and close to the optical axis between focus F and centre of curvature C of a converging mirror of focal length f as shown in figure.

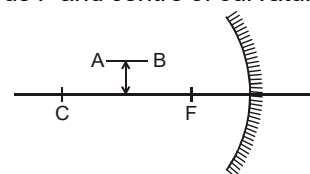

- (A) Image of A will be closer than that of B from the mirror.  
 (B) Image of AB will be parallel to the optical axis.  
 (C) Image of AB will be straight line inclined to the optical axis.  
 (D) Image of AB will not be straight line.

4. A satellite is moving around the earth in a circular orbit and in this orbit magnitude of its acceleration is 'a<sub>1</sub>'. Now a rocket is fired in the direction of motion of satellite from the satellite due to which its speed instantaneously becomes half of initial, just after the rocket is fired acceleration of satellite have magnitude 'a<sub>2</sub>'. Then fill the

ratio  $\frac{a_1}{a_2}$  in answer sheet (Assume there is no external force other than the gravitational force of earth before and after the firing of rocket from the satellite)

5. A bird is singing on a tree and a man is hearing at a distance 'r' from the bird. Calculate the displacement of the man towards the bird so that the loudness heard by man increases by 20 dB. [Assume that the motion of man is along the line joining the bird and the man]

**COMPREHENSION**

A uniform rod AB of length 'l' is thrown upwards such that initially AB is horizontal, velocity of centre is 'u' upwards and angular velocity 'ω' is such that velocity of 'B' at this moment is zero. The values of 'ω' and 'u' are also such that the rod becomes vertical first time at the moment when the centre of rod reaches the highest point of its motion.

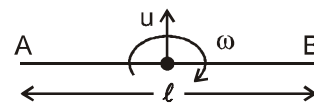

6. The value of 'ω' in terms of 'u' and 'l' is equal to

- (A)  $\frac{u}{l}$  (B)  $\frac{2u}{l}$  (C)  $\frac{u}{2l}$  (D)  $\frac{u}{4l}$

7. The value of 'u' is equal to

- (A)  $\sqrt{\frac{\pi l g}{4}}$  (B)  $\sqrt{gl}$  (C)  $\sqrt{\frac{\pi l g}{2}}$  (D)  $\sqrt{\frac{gl}{2}}$

8. The angular acceleration of the rod during the motion is

- (A)  $\frac{g}{l}$  (B)  $\frac{2g}{l}$  (C) 0 (D)  $\frac{u^2}{l}$

**Topics : Circular Motion, Relative Motion, Rectilinear Motion, Gravitation, Electrostatics, Geometrical Optics**

**Type of Questions**

		<b>M.M., Min.</b>
Single choice Objective ('-1' negative marking) Q.1 to Q.2	(3 marks, 3 min.)	[6, 6]
Multiple choice objective ('-1' negative marking) Q.3	(4 marks, 4 min.)	[4, 4]
Subjective Questions ('-1' negative marking) Q.4	(4 marks, 5 min.)	[4, 5]
Comprehension ('-1' negative marking) Q.5 to Q.7	(3 marks, 3 min.)	[9, 9]
Match the Following (no negative marking) (2 × 4) Q. 8	(8 marks, 10 min.)	[8, 10]

1. A section of fixed smooth circular track of radius  $R$  in vertical plane is shown in the figure. A block is released from position A and leaves the track at B. The radius of curvature of its trajectory when it just leaves the track at B is:

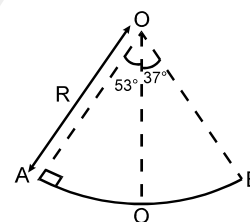

- (A)  $R$  (B)  $\frac{R}{4}$   
 (C)  $\frac{R}{2}$  (D) none of these

2. A cyclist observes a passenger in a bus. He finds that the passenger closed his glass window displacing 20 cm in forward direction with constant speed in 1 sec. Bus overtakes the cyclist in 3 sec. Initially he was at the middle of the bus as shown in the figure. Length of the bus is 18 m. Both cyclist and bus are moving with constant speed in the same direction. Then velocity of the glass window with respect to cyclist was:

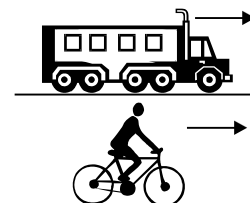

- (A) 0.2 m/s (B) 2.8 m/s (C) 3.2 m/s (D) 3 m/s

3. A particle is moving rectilinearly so that its acceleration is given as  $a = 3t^2 + 1 \text{ m/s}^2$ . Its initial velocity is zero.

- (A) The velocity of the particle at  $t=1$  sec will be 2m/s.  
 (B) The displacement of the particle in 1 sec will be 2m.  
 (C) The particle will continue to move in positive direction.  
 (D) The particle will come back to its starting point after some time.

4. A particle is projected from point A, that is at a distance  $4R$  from the centre of the earth, with speed  $V_1$  in a direction making  $30^\circ$  with the line joining the centre of the earth and point A, as shown. Find the speed  $V_2$  if particle passes grazing the surface of the earth. Consider gravitational interaction only between these two. (use  $\frac{GM}{R} = 6.4 \times 10^7 \text{ m}^2/\text{s}^2$ ) Express you answer in the form  $\frac{X}{\sqrt{2}} \text{ m/s}$  and fill value of X.

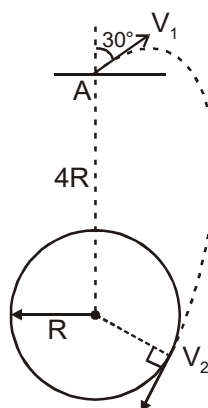

**COMPREHENSION**

A point charge  $q_1 = +6e$  fixed at the origin of a coordinate system, and another point charge  $q_2 = -10e$  is fixed at  $x = 8 \text{ nm}$ ,  $y = 0$ . The locus of all points in the  $xy$  plane for which potential  $V = 0$  (other than infinity) is a circle centered on the  $x$ -axis, as shown.

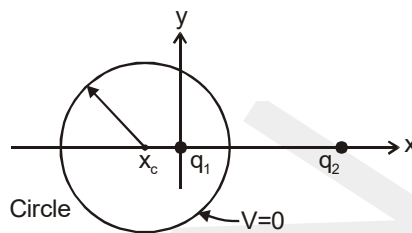

5. Radius  $R$  of the circle is  
 (A) 3nm (B) 6nm  
 (C) 7.5nm (D) 9nm
6.  $x$ -coordinate of the centre of the circle is -  
 (A) -2nm (B) -3nm (C) -4.5nm (D) -7.5nm
7. The potential at the centre of the circle is  
 (A) 0.32V (B) 0.77V (C) 1.2V (D) -1.2V
8. An object  $O$  (real) is placed at focus of an equi-biconvex lens as shown in figure 1. The refractive index of lens is  $\mu = 1.5$  and the radius of curvature of either surface of lens is  $R$ . The lens is surrounded by air. In each statement of column I some changes are made to situation given above and information regarding final image formed as a result is given in column-II. The distance between lens and object is unchanged in all statements of column-I. Match the statements in column-I with resulting image in column-II.

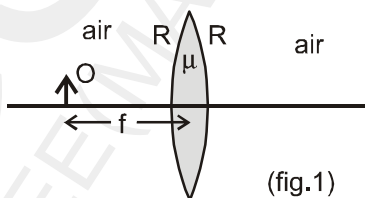

**Column-I**

- (A) If the refractive index of the lens is doubled (that is, made  $2\mu$ ) then
- (B) If the radius of curvature is doubled (that is, made  $2R$ ) then
- (C) If a glass slab of refractive index  $\mu = 1.5$  is introduced between the object and lens as shown, then

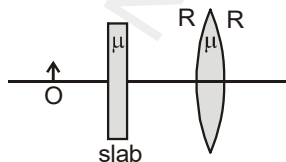

- (D) If the left side of lens is filled with a medium of refractive index  $\mu = 1.5$  as shown, then

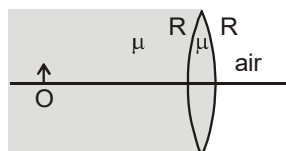

**Column-II**

- (p) final image is real
- (q) final image is virtual
- (r) final image becomes smaller in size in comparison to size of image before the change was made
- (s) final image is of same size of object.

**Topics : Rectilinear Motion, Relative Motion, Circular Motion, Sound Wave, Electrostatics**

**Type of Questions**

Type of Questions	M.M., Min.
Single choice Objective ('-1' negative marking) Q.1 to Q.2	(12 marks 12 min.) [6, 6]
Subjective Questions ('-1' negative marking) Q.3 to Q.4	(4 marks, 5 min.) [8, 10]
Comprehension ('-1' negative marking) Q.5 to Q.7	(3 marks, 3 min.) [9, 9]
Match the Following (no negative marking) (2 × 4) Q.8	(8 marks, 10 min.) [8, 10]

1. A particle moves along x-axis with initial position  $x = 0$ . Its velocity varies with x-coordinate as shown in graph. The acceleration 'a' of this particle varies with x as

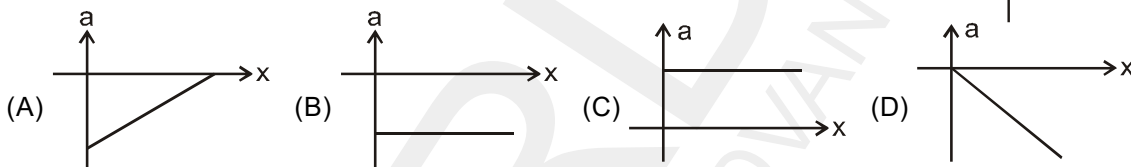
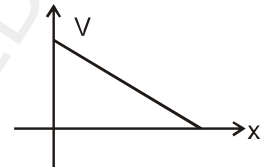

2. A coin is released inside a lift at a height of 2 m from the floor of the lift. The height of the lift is 10 m. The lift is moving with an acceleration of  $9 \text{ m/s}^2$  downwards. The time after which the coin will strike with the lift is : ( $g = 10 \text{ m/s}^2$ )
- (A) 4 s                      (B) 2 s                      (C)  $\frac{4}{\sqrt{21}}$  s                      (D)  $\frac{2}{\sqrt{11}}$  s
3. A particle is projected from ground with an initial velocity 20 m/sec making an angle  $60^\circ$  with horizontal. If  $R_1$  and  $R_2$  are radius of curvatures of the particle at point of projection and highest point respectively, then find the value of  $\frac{R_1}{R_2}$ .
4. A point source of sound emitting sound of frequency 700 Hz and observer starts moving from a point along mutually perpendicular directions with velocity 20 m/s and 15 m/s respectively. If change in observed frequency by observer is  $10x$  Hz then calculate 'x'. [speed of sound in 334 m/sec]

**COMPREHENSION**

A thin ring of radius R metres is placed in x-y plane such that its centre lies on origin. The half ring in region  $x < 0$  carries uniform linear charge density  $+\lambda$  C/m and the remaining half ring in region  $x > 0$  carries uniform linear charge density  $-\lambda$  C/m.

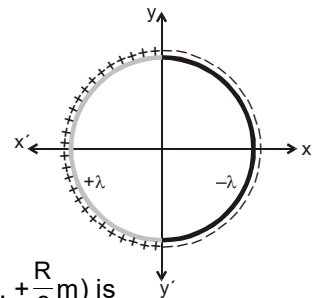

5. Then the electric potential (in volts) at point P whose coordinates are  $(0\text{m}, +\frac{R}{2}\text{m})$  is
- (A)  $\frac{1}{4\pi\epsilon_0} \frac{\lambda}{2}$                       (B) 0                      (C)  $\frac{1}{4\pi\epsilon_0} \frac{\lambda}{4}$                       (D) cannot be determined
6. Then the direction of electric field at point P whose coordinates are  $(0\text{m}, +\frac{R}{2}\text{m})$  is
- (A) Along positive x-direction                      (B) Along negative x-direction  
 (C) Along negative y-direction                      (D) None of these
7. Then the dipole moment of the ring in C-m is
- (A)  $-(2\pi R^2\lambda)\hat{i}$                       (B)  $(2\pi R^2\lambda)\hat{i}$                       (C)  $-(4R^2\lambda)\hat{i}$                       (D)  $(4R^2\lambda)\hat{i}$

8. Match the column :  
 Column-I

Column-II

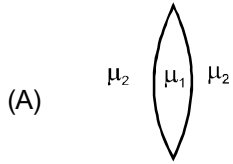

If  $\mu_2 > \mu_1$

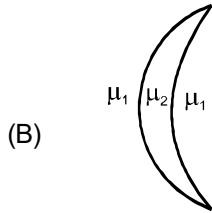

If  $\mu_2 > \mu_1$

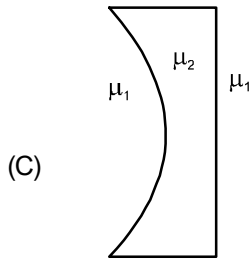

If  $\mu_2 < \mu_1$

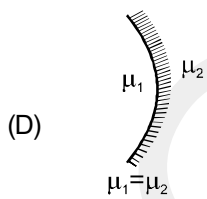

$\mu_1 = \mu_2$

(p) Optical power will be positive

(q) Optical power will be negative

(r) System will converge a parallel beam of light incident on it

(s) Focal length will be positive

(t) Focal length will be negative

**Topics : Electrostatics, Rectilinear Motion, Relative Motion, Simple Harmonic Motion**

**Type of Questions**

Single choice Objective ('-1' negative marking) Q.1 to Q.4	(3 marks, 3 min.)	<b>M.M., Min.</b> [12, 12]
Comprehension ('-1' negative marking) Q.5 to Q.7	(3 marks, 3 min.)	[9, 9]
Match the Following (no negative marking) (2 × 4) Q.8	(8 marks, 10 min.)	[8, 10]

1. Two infinitely large charged planes having uniform surface charge density  $+\sigma$  and  $-\sigma$  are placed along x-y plane and yz plane respectively as shown in the figure. Then the nature of electric lines of forces in x-z plane is given by :

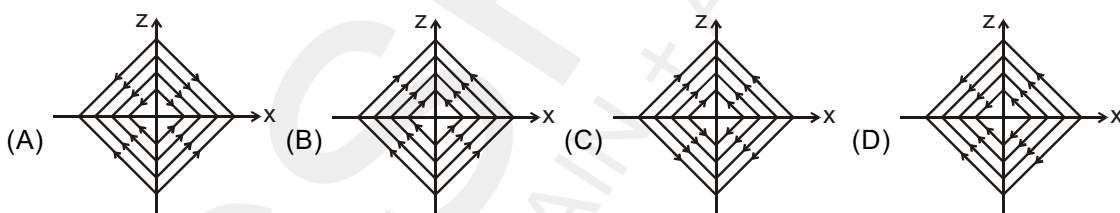
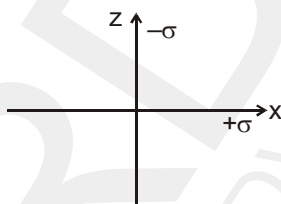

2. A point charge placed on the axis of a uniformly charged disc experiences a force  $f$  due to the disc. If the charge density on the disc is  $\sigma$ , the electric flux through the disc, due to the point charge will be :

(A)  $\frac{2\pi f}{\sigma}$       (B)  $\frac{f}{2\pi\sigma}$       (C)  $\frac{f^2}{\sigma}$       (D)  $\frac{f}{\sigma}$

3. A particle moves along x-axis in positive direction. Its acceleration 'a' is given as  $a = cx + d$ , where x denotes the x-coordinate of particle, c and d are positive constants. For velocity-position graph of particle to be of type as shown in figure, the value of speed of particle at  $x = 0$  should be.

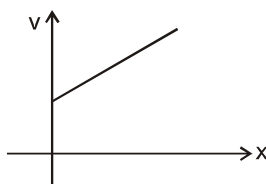

(A)  $\sqrt{\frac{4d^2}{c}}$       (B)  $\sqrt{\frac{d^2}{c}}$       (C)  $\sqrt{\frac{2d^2}{c}}$       (D)  $\sqrt{\frac{8d^2}{c}}$

4. P is a point moving with constant speed 10 m/s such that its velocity vector always maintains an angle  $60^\circ$  with line OP as shown in figure (O is a fixed point in space). The initial distance between O and P is 100 m. After what time shall P reach O.

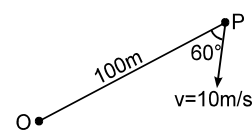

(A) 10 sec.      (B) 15 sec.      (C) 20 sec.      (D)  $20\sqrt{3}$  sec

**COMPREHENSION**

A solid cylinder attached with a horizontal massless spring (see figure) can roll without slipping along a horizontal surface. If the system is released from rest at a position in which spring is stretched by 0.3 m.

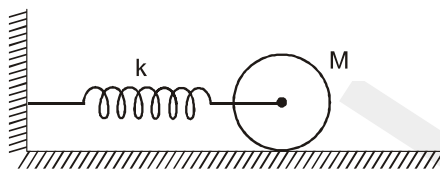

5. Period of oscillation of c.o.m of cylinder is

- (A)  $2\pi\sqrt{\frac{M}{k}}$       (B)  $2\pi\sqrt{\frac{3M}{2k}}$       (C)  $2\pi\sqrt{\frac{2M}{3k}}$       (D)  $2\pi\sqrt{\frac{M}{2k}}$

6. If  $k = 20 \text{ N/m}$ , Rotational K.E. of cylinder as it passes through mean position is

- (A) 0.3 J      (B) 0.45 J      (C) 0.6 J      (D) 0.9 J

7. Translation K.E. of cylinder as it passes through mean position is

- (A) 0.3 J      (B) 0.45 J      (C) 0.6 J      (D) 0.9 J

8. instruments are given. In column II, there are results corresponding to a given situation. Match the optical instrument of column I with the results in column II.

**Column I**

- (A) concave mirror  
 (B) convex mirror  
 (C) concave lens  
 (D) convex lens

**Column II**

- (p) Parallel rays can be obtained by using point source.  
 (q) Real image can be obtained for real object.  
 (r) Virtual and diminished image can be obtained for real object.  
 (s) Real and magnified image can be obtained for real object.  
 (t) For a point object moving along optical axis, the image also moves in the same direction of motion of the object.

**Topics : Rectilinear Motion, Friction, Circular Motion, Gravitation, Relative Motion, Electrostatics**

**Type of Questions**

**Single choice Objective ('-1' negative marking) Q.1 to Q.5**

**(3 marks, 3 min.)**

**M.M., Min.**

**[15, 15]**

**Comprehension ('-1' negative marking) Q.6 to Q.8**

**(3 marks, 3 min.)**

**[9, 9]**

1. A particle moves along a path ABCD as shown in the figure. Then the magnitude of net displacement of the particle from position A to D is :

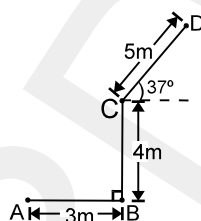

- (A) 10 m  
 (B)  $5\sqrt{2}$  m  
 (C) 9 m  
 (D)  $7\sqrt{2}$  m

2. A block of mass 20 kg is acted upon by a force  $F = 30$  N at an angle  $53^\circ$  with the horizontal in downward direction as shown. The coefficient of friction between the block and the horizontal surface is 0.2. The friction force acting on the block by the ground is ( $g = 10$  m/s<sup>2</sup>)

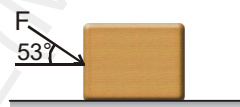

- (A) 40.0 N  
 (B) 30.0 N  
 (C) 18.0 N  
 (D) 44.8 N

3. The wire of the potentiometer has resistance 4 ohms and length 1 m. It is connected to a cell of e.m.f. 2 volts and internal resistance 1 ohm. If a cell of e.m.f. 1.2 volts is balanced by it, the balancing length will be:

- (A) 90 cm  
 (B) 60 cm  
 (C) 50 cm  
 (D) 75 cm

4. If the apparent weight of the bodies at the equator is to be zero, then the earth should rotate with angular velocity

- (A)  $\sqrt{\frac{g}{R}}$  rad/sec  
 (B)  $\sqrt{\frac{2g}{R}}$  rad/sec  
 (C)  $\sqrt{\frac{g}{2R}}$  rad/sec  
 (D)  $\sqrt{\frac{3g}{2R}}$  rad/sec

5. A particle 'A' is rotating in a circle of radius  $R$  with centre at  $O$ . Another particle B in the same plane is resting at point Q which is at a distance  $d$  from  $O$ . The path of B as seen from A is :

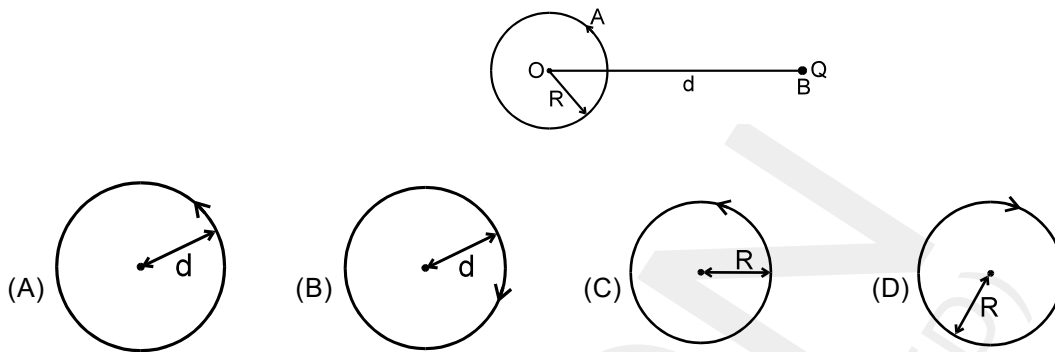

### COMPREHENSION

Two uniformly charged fixed rings, each of radius  $R$  are separated by a distance of  $3r$  ( $r \gg R$ ). Ring, 1 has charge  $Q$  and ring 2 has net charge  $4Q$ . A neutral point is a point in space at which the value of electric field intensity is zero, while its value is non zero at any neighbouring point.

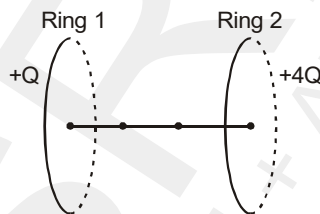

6. The position of a neutral point  $N$  is at a distance of  
 (A)  $r$  from the center of ring 1 towards right  
 (B)  $2r$  from the center of ring 1 towards right  
 (C)  $r$  from the center of ring 1 towards left  
 (D) None of these
7. A negatively charged particle is projected from the center of ring 1 towards the neutral point  $N$  with just enough energy to pass the neutral point. Its subsequent motion will be  
 (A) Oscillatory  
 (B) SHM  
 (C) Unidirectional  
 (D) Non oscillatory rectilinear but not unidirectional
8. A positively charged particle is released from the center of ring 2 by slightly pushing it towards left. Its subsequent motion will be  
 (A) Oscillatory  
 (B) SHM  
 (C) Unidirectional  
 (D) Non oscillatory rectilinear but not unidirectional

**Topics : Electrostatics, Friction, Circular Motion, Current Electricity**

**Type of Questions**

Type of Questions	M.M., Min.
Single choice Objective ('-1' negative marking) Q.1 to Q.2	(3 marks, 3 min.) [6, 6]
Multiple choice objective ('-1' negative marking) Q.3	(4 marks, 4 min.) [4, 4]
Comprehension ('-1' negative marking) Q.4 to Q.8	(3 marks, 3 min.) [15, 15]

1. The figure shows two large, closely placed, parallel, nonconducting sheets with identical (positive) uniform surface charge densities, and a sphere with a uniform (positive) volume charge density. Four points marked as 1, 2, 3 and 4 are shown in the space in between. If  $E_1, E_2, E_3$  and  $E_4$  are magnitude of net electric fields at these points respectively then :

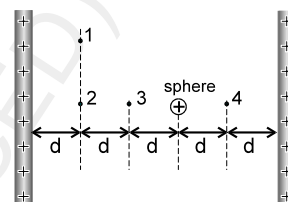

- (A)  $E_1 > E_2 > E_3 > E_4$  (B)  $E_1 > E_2 > E_3 = E_4$   
 (C)  $E_3 = E_4 > E_2 > E_1$  (D)  $E_1 = E_2 = E_3 = E_4$

2. A particle of mass 5 kg is moving on rough fixed inclined plane (making an angle  $30^\circ$  with horizontal) with constant velocity of 5 m/s as shown in the figure. Find the friction force acting on a body by the inclined plane.

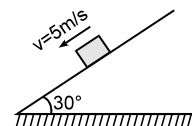

- ( take  $g = 10\text{m/s}^2$  )  
 (A) 25 N (B) 20 N (C) 30 N (D) none of these

3. AB is a potentiometer wire of length L, which is connected to an accumulator.

The potential gradient in AB can be decreased by:

- (A) increasing the radius of AB  
 (B) decreasing the radius of AB  
 (C) increasing a resistance in series with AB  
 (D) all the above.

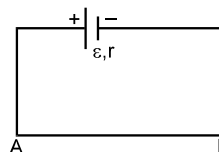

**COMPREHENSION**

A high tension wire is at a high potential with respect to a wire which is well grounded called 'Earth wire'. You must have seen such wires stretched parallel to roads. There is a high tension wire between two points A and B, 1 km apart. The distance between HT wire and earth wire is 1 m. The resistance of the HT (and also the earth wire) is  $1 \Omega/\text{m}$ . This wire is at a potential of 11 KV at point A w.r. to earth wire., and its is carrying 1A current which returns back to the generator by through the earth wire. This wire is quite a thick wire. There is a sign board at a pole over which this wire is stretched reading 'DANGER, 11 KV'. You might think what would happen if one touched this wire. Will one feel a shock or not. Well ! it depends on whether the current through our body exceeds a particular value, which we may call CRITICAL CURRENT.

4. Why is H.T. wire thick wire. Select the most appropriate option  
 (A) so that more current may flow  
 (B) so that resistance may be less thereby reducing power loss in the transmission line.  
 (C) so that it may bear high tension & therefore sag less.  
 (D) so that when in future population increases, the existing wire may serve the purpose.
5. Consider a bird having effective resistance  $10\Omega$  between its feet sitting on this high tension wire. The distance between its feet is 10 cm. Find the potential difference between the feet of the bird is approximately.  
 (A) 0.1 V (B) 1 V (C) 10 V (D) 0.05 V
6. In the above question find the current through the bird.  
 (A) 10 A (B) 1 A (C) 0.01 A (D) 0.005 A
7. If the potential difference between H.T. and earth wire is 11 kV at point A, find p.d. between these wires at point B.  
 (A) 1 KV (B) 2 KV (C) 9 KV (D) 10 KV
8. If the 'Critical Current' for the bird is 0.1 A, find the maximum power at 11 KV can be transmitted at point A so that the bird may not get shock. Assume that the distance between the feet is 10 cm.



- (A) 111 KW (B) 11 KW (C) 101 KW (D) 110011 KW

**Topics : Electrostatics, Kinematics, Current Electricity, Center of Mass, Newton's Law of Motion**

**Type of Questions**

Type of Questions	M.M., Min.
Single choice Objective ('-1' negative marking) Q.1 to Q.4	(3 marks, 3 min.) [12, 12]
Subjective Questions ('-1' negative marking) Q.5	(4 marks, 5 min.) [4, 5]
Comprehension ('-1' negative marking) Q.6 to Q.8	(3 marks, 3 min.) [9, 9]

1. There exists a uniform electric field in the space as shown. Four points A, B, C and D are marked which are equidistant from the origin. If  $V_A, V_B, V_C$  and  $V_D$  are their potentials respectively, then

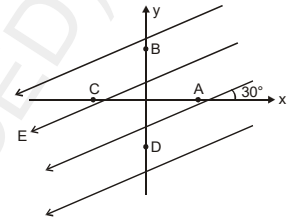

- (A)  $V_B > V_A > V_C > V_D$                       (B)  $V_A > V_B > V_D > V_C$   
 (C)  $V_A = V_B > V_C = V_D$                       (D)  $V_B > V_C > V_A > V_D$

2. The displacement time graphs of two bodies A and B are shown in figure. The ratio of velocity of A,  $v_A$  to velocity of B,  $v_B$  is :

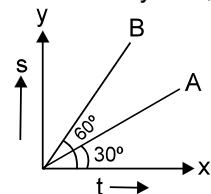

- (A)  $\frac{1}{\sqrt{3}}$     (B)  $\sqrt{3}$   
 (C)  $\frac{1}{3}$     (D) 3

3. In the circuit shown, the galvanometer shows zero current. The value of resistance R is :

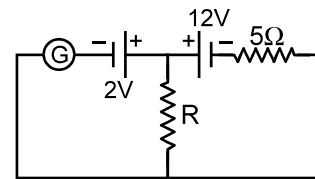

- (A) 1 Ω    (B) 2 Ω  
 (C) 4 Ω    (D) 9 Ω

4. A disc of mass 'm' and radius R is free to rotate in horizontal plane about a vertical smooth fixed axis passing through its centre. There is a smooth groove along the diameter of the disc and two small balls of mass  $\frac{m}{2}$  each are placed in it on either side of the centre of the disc as shown in fig. The disc is given initial angular velocity  $\omega_0$  and released. The angular speed of the disc when the balls reach the end of disc is :

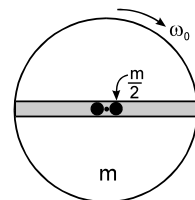

- (A)  $\frac{\omega_0}{2}$                       (B)  $\frac{\omega_0}{3}$                       (C)  $\frac{2\omega_0}{3}$                       (D)  $\frac{\omega_0}{4}$

5. A small block A is placed on a smooth inclined wedge B which is placed on a horizontal smooth surface. B is fixed and A is released from top of B. A slide down along the incline and reaches bottom in time  $t_1$ . In second case A is released from top of B, but B is also free to move on horizontal surface. The block A takes  $t_2$  time to reach bottom. Without actually calculating the values of  $t_1$  and  $t_2$  find which is greater.

**COMPREHENSION**

A car battery with a 12 V emf and an internal resistance of 0.04 Ω is being charged with a current of 50 A.

6. The potential difference V across the terminals of the battery are  
 (A) 10 V                      (B) 12 V                      (C) 14 V                      (D) 16 V
7. The rate at which energy is being dissipated as heat inside the battery is :  
 (A) 100 W                      (B) 500 W                      (C) 600 W                      (D) 700 W
8. The rate of energy conversion from electrical form to chemical form is :  
 (A) 100 W                      (B) 500 W                      (C) 600 W                      (D) 700 W

**Topics : Current Electricity, Capacitance, Sound Wave, Kinematics**

**Type of Questions**

		<b>M.M., Min.</b>
<b>Single choice Objective ('-1' negative marking) Q.1 to Q.3</b>	<b>(3 marks, 3 min.)</b>	<b>[9, 9]</b>
<b>Subjective Questions ('-1' negative marking) Q.4 to Q.5</b>	<b>(4 marks, 5 min.)</b>	<b>[8, 10]</b>
<b>Comprehension ('-1' negative marking) Q.6 to Q.8</b>	<b>(3 marks, 3 min.)</b>	<b>[9, 9]</b>

1. An ammeter and a voltmeter are initially connected in series to a battery of zero internal resistance. When switch  $S_1$  is closed the reading of the voltmeter becomes half of the initial, whereas the reading of the ammeter becomes double. If now switch  $S_2$  is also closed, then reading of ammeter becomes:

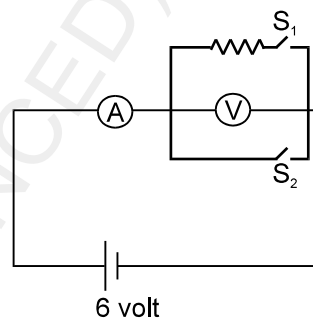

- (A) 3/2 times the initial value
- (B) 3/2 times the value after closing  $S_1$
- (C) 3/4 times the value after closing  $S_1$
- (D) 3/4 times the initial value

2. A circuit has a section AB shown in the figure. The emf of the source equals  $\epsilon = 10V$ , the capacitance as of the capacitors are equal to  $C_1 = 1.0 \mu F$  and  $C_2 = 2.0 \mu F$ , the potential difference  $\phi_A - \phi_B = 5.0V$ . The voltage across capacitor  $C_1$  &  $C_2$  is respectively :

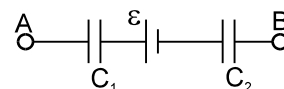

- (A) 10/3 V, 5/3 V
- (B) 10/3 V, 10/3 V
- (C) 5/3 V, 5/3 V
- (D) 0 V, 0 V

3. Under similar conditions of temperature and pressure, In which of the following gases the velocity of sound will be largest.

- (A)  $H_2$
- (B)  $N_2$
- (C) He
- (D)  $CO_2$

4. A rigid body is made of three identical thin rods fastened together in the form of letter H. The body is free to rotate about a fixed horizontal axis AB that passes through one of the legs of the H. The body is allowed to fall from rest from a position in which the plane of H is horizontal. What is the angular speed of the body when the plane of H is vertical. Top View of the figure in the initial position.

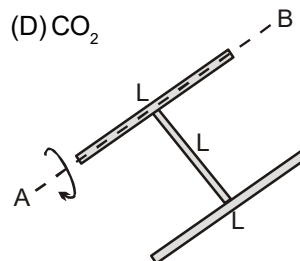

5. A man holding a flag is running in North-East direction with speed 10 m/s. Wind is blowing in east direction with speed  $5\sqrt{2}$  m/s. Find the direction in which flag will flutter.

**COMPREHENSION**

AB is a uniform wire of meter bridge, across which an ideal 20 volt cell is connected as shown. Two resistor of  $1 \Omega$  and  $X \Omega$  are inserted in slots of metre bridge. A cell of emf E volts and internal resistance  $r \Omega$  and a galvanometer is connected to jockey J as shown.

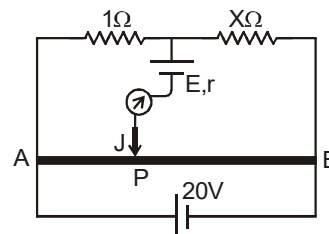

- 6. If  $E = 16$  volts,  $r = 4 \Omega$  and distance of balance point P from end A is 90 cm, then the value of X is :  
 (A)  $3 \Omega$                       (B)  $6 \Omega$                       (C)  $9 \Omega$                       (D)  $12 \Omega$
- 7. If  $E = 16$  volts,  $r = 8 \Omega$  and  $X = 9 \Omega$ , then the distance of balance point P from end A is :  
 (A) 10 cm                      (B) 30 cm                      (C) 60 cm                      (D) 90 cm
- 8. If  $E = 12$  volts,  $X = 9 \Omega$ , then distance of balance point P from end A is  
 (A) 20 cm                      (B) 50 cm                      (C) 70 cm                      (D) Data insufficient

**Topics : Current Electricity, Capacitance, Sound, Electrostatics**

**Type of Questions**

**Single choice Objective ('-1' negative marking) Q.1 to Q.3**

**(3 marks, 3 min.)**

**M.M., Min.**

**[9, 9]**

**Multiple choice objective ('-1' negative marking) Q.4**

**(4 marks, 4 min.)**

**[4, 4]**

**Comprehension ('-1' negative marking) Q.5 to Q.8**

**(3 marks, 3 min.)**

**[12, 12]**

1. In the circuit shown, cells are of equal emf  $E$  but of different internal resistances  $r_1 = 6\Omega$  and  $r_2 = 4\Omega$ . Reading of the ideal voltmeter connected across cell 1 is zero. Value of the external resistance  $R$  in ohm is equal to-

- (A) 2 (B) 2.4 (C) 10 (D) 24

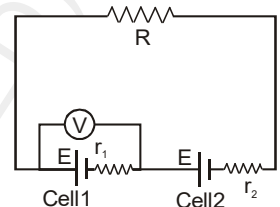

2. The circuit was in the shown state for a long time. Now if the switch  $S$  is closed then the net charge that flows through the switch  $S$ , will be

- (A)  $\frac{400}{3} \mu\text{C}$  (B)  $100 \mu\text{C}$   
 (C)  $\frac{100}{3} \mu\text{C}$  (D)  $50 \mu\text{C}$

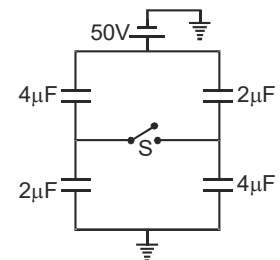

3. The equation of displacement due to a sound wave is  $s = s_0 \sin^2(\omega t - kx)$ . If the bulk modulus of the medium is  $B$ , then the equation of pressure variation due to that sound is

- (A)  $B k s_0 \sin(2\omega t - 2kx)$  (B)  $-B k s_0 \sin(2\omega t - 2kx)$   
 (C)  $B k s_0 \cos^2(\omega t - kx)$  (D)  $-B k s_0 \cos^2(\omega t - kx)$

4. Four point charges are fixed on  $y$ -axis as shown in figure. When a positive test charge at origin is given a finite impulse along positive  $x$ -axis,

which of the following is/are correct option/options :

- (A) Test charge may pass through origin with same momentum once again.  
 (B) Test charge must return at origin at least once.  
 (C) Test charge may perform SHM on  $x$ -axis.  
 (D) Test charge may reach upto infinite distance on positive  $x$ -axis.

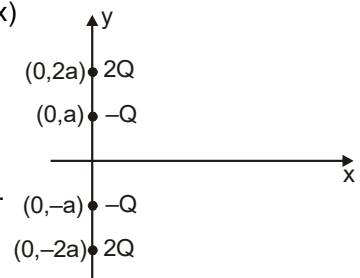

**COMPREHENSION**

A wire  $AB$  (of length  $1\text{m}$ , area of cross section  $\pi\text{m}^2$ ) is used in potentiometer experiment to calculate emf and internal resistance ( $r$ ) of battery. The emf and internal resistance of driving battery are  $15\text{V}$  and  $3\Omega$  respectively. The resistivity of wire  $AB$  varies as  $\rho = \rho_0 x$  (where  $x$  is distance from  $A$  in meters and  $\rho_0 = 24\pi \Omega$ )

The distance of null point from  $A$  is obtained at  $\sqrt{\frac{2}{3}}$  m when switch ' $S$ ' is open and at  $\frac{1}{\sqrt{2}}$  m when switch is closed.

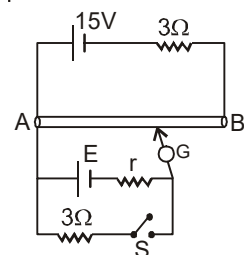

5. The resistance of whole wire  $AB$  is -

- (A)  $6\Omega$  (B)  $12\Omega$  (C)  $18\Omega$  (D)  $24\Omega$

6. The current through  $15\text{V}$  battery (with  $I_G = 0$ )

- (A) is  $1\text{A}$  only when switch  $S$  is closed (B) is  $1\text{A}$  only when switch  $S$  is open  
 (C) is  $1\text{A}$  in both cases (D) can not be calculated.

7. The emf ( $E$ ) of battery is -

- (A)  $4\text{V}$  (B)  $6\text{V}$  (C)  $8\text{V}$  (D)  $10\text{V}$

8. Internal resistance of battery  $E$  is -

- (A)  $4\Omega$  (B)  $3\Omega$  (C)  $2\Omega$  (D)  $1\Omega$



5. Find the potential difference between points A and B of the system shown in the figure, if the emf is equal to

$\mathcal{E} = 110\text{V}$  and the capacitance ratio  $\frac{C_2}{C_1} = \eta = 2.0$ .

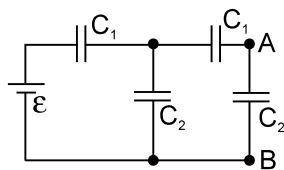

**COMPREHENSION**

A thin uniform rod having mass  $m$  and length  $4\ell$  is free to rotate about horizontal axis passing through a point distant  $\ell$  from one of its end, as shown in figure. It is released, from the horizontal position as shown :



6. What will be acceleration of centre of mass at this instant  
 (A)  $\frac{3g}{7}$                       (B)  $\frac{2g}{7}$                       (C)  $\frac{3g}{5}$                       (D)  $\frac{2g}{5}$
7. What will be normal reaction due to hinge at the instant of release  
 (A)  $mg$                       (B)  $\frac{mg}{2}$                       (C)  $\frac{4mg}{7}$                       (D)  $\frac{\sqrt{2}mg}{7}$
8. What will be angular velocity of rod when it becomes vertical  
 (A)  $\sqrt{\frac{6g}{7\ell}}$                       (B)  $\sqrt{\frac{12g}{7\ell}}$                       (C)  $\sqrt{\frac{3g}{2\ell}}$                       (D)  $\sqrt{\frac{3g}{7\ell}}$

**Topics : Rotation, Capacitor, Center of Mass, Gravitation, Current Electricity, Electrostatics**

Type of Questions		M.M., Min.
Single choice Objective ('-1' negative marking) Q.1 to Q.2	(3 marks, 3 min.)	[6, 6]
Multiple choice objective ('-1' negative marking) Q.3	(4 marks, 4 min.)	[4, 4]
Subjective Questions ('-1' negative marking) Q.4 to Q.5	(4 marks, 5 min.)	[8, 10]
Comprehension ('-1' negative marking) Q.6 to Q.8	(3 marks, 3 min.)	[9, 9]

1. A uniform thin rod is bent in the form of a closed loop ABCDEFA as shown in the figure.

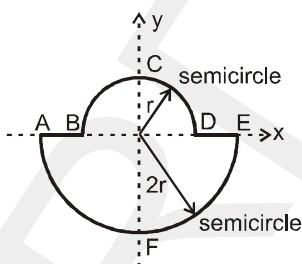

- (A)  $> 1$  (B)  $< 1$   
 (C)  $= 1$  (D)  $= 1/2$
2. An uncharged parallel plate capacitor is connected to a battery. The electric field between the plates is  $10\text{V/m}$ . Now a dielectric of dielectric constant 2 is inserted between the plates filling the entire space. The electric field between the plates now is
- (A)  $5\text{ V/m}$  (B)  $20\text{ V/m}$   
 (C)  $10\text{ V/m}$  (D) none of these
3. In the figure shown, coefficient of restitution between A and B is  $e = \frac{1}{2}$ , then :

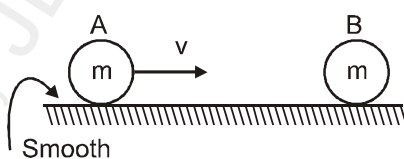

- (A) velocity of B after collision is  $\frac{v}{2}$   
 (B) impulse on one of the balls during collision is  $\frac{3}{4}mv$   
 (C) loss of kinetic energy in the collision is  $\frac{3}{16}mv^2$   
 (D) loss of kinetic energy in the collision is  $\frac{1}{4}mv^2$

4. A spherical planet has uniform density  $\frac{\pi}{2} \times 10^4 \text{ kg/m}^3$ . Find out the minimum period for a satellite in a circular orbit around it in seconds. (Use  $G = \frac{20}{3} \times 10^{-11} \frac{\text{N-m}^2}{\text{kg}^2}$ ).
5. Two potentiometer wires  $w_1$  and  $w_2$  of equal length  $\ell$  connected to a battery of emf  $\varepsilon_p$  and internal resistance 'r' through two switches  $s_1$  and  $s_2$ . A battery of emf  $\varepsilon$  is balanced on these potentiometer wires. If potentiometer wire  $w_1$  is of resistance  $2r$  and balancing length on  $w_1$  is  $\ell/2$  when only  $s_1$  is closed and  $s_2$  is open. On closing  $s_2$  and opening  $s_1$  the balancing length on  $w_2$  is found to be  $\left(\frac{2\ell}{3}\right)$ , then find the resistance of potentiometer wire  $w_2$ .

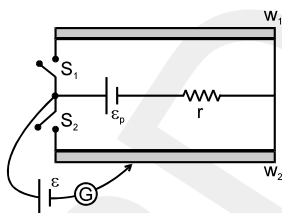

### COMPREHENSION

Two conducting spheres of radius  $R$  and  $3R$  carry charges  $Q$  and  $-2Q$ . Between these spheres a neutral conducting sphere of radius  $2R$  is connected. The separation between the sphere is considerably large. Charge flows through conducting wire due to potential difference.

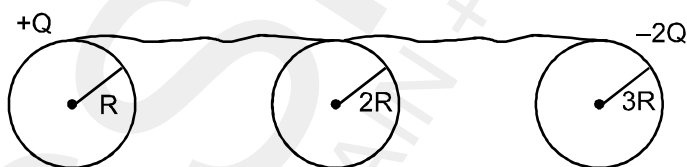

6. The final charge on initially neutral conducting sphere is :
- (A)  $-\frac{Q}{6}$       (B)  $-\frac{Q}{3}$       (C)  $\frac{Q}{3}$       (D)  $-\frac{Q}{2}$
7. The decrease in electric potential energy of sphere of radius  $R$  is :
- (A)  $\frac{KQ^2}{4R}$       (B)  $\frac{35KQ^2}{72R}$       (C)  $\frac{KQ^2}{72R}$       (D) none
8. The final electric potential of sphere of radius  $3R$  will be :
- (A)  $-\frac{KQ}{6R}$       (B)  $-\frac{KQ}{2R}$       (C)  $-\frac{2KQ}{3R}$       (D)  $-\frac{3KQ}{R}$

**Topics : Center of Mass, Rotation, Current Electricity, Capacitor, Gravitation, Electrostatics**

**Type of Questions**

Type of Questions	M.M., Min.
Single choice Objective ('-1' negative marking) Q.1 to Q.4	(3 marks, 3 min.) [9, 9]
Subjective Questions ('-1' negative marking) Q.5	(4 marks, 5 min.) [4, 5]
Comprehension ('-1' negative marking) Q.6 to Q.8	(3 marks, 3 min.) [9, 9]

1. A projectile of range  $R$  bursts at its highest point in two fragments. Both pieces at the time of bursts have the velocity in the horizontal direction. The heavier is double the mass of the lighter. Lighter fragment falls at  $\frac{R}{2}$  horizontal distance from the point of projection in the opposite side of projection. The distance, where other part falls, from point of projection.

- (A)  $\frac{7R}{4}$                       (B)  $\frac{5R}{4}$                       (C)  $\frac{8R}{4}$                       (D)  $\frac{6R}{4}$

2. There are four arrangements of a cylinder and a plank as shown in the figures. Some surfaces are smooth and some are rough as indicated. There is no slipping at each rough surface. String always remains tight. The plank and/or centre of cylinder are given a horizontal constant velocity as shown in each of the situations. Using this information fill in the blanks.

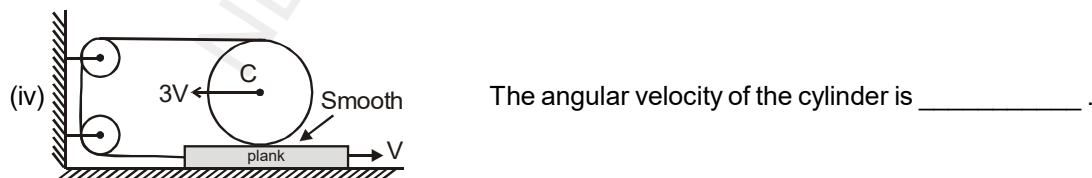
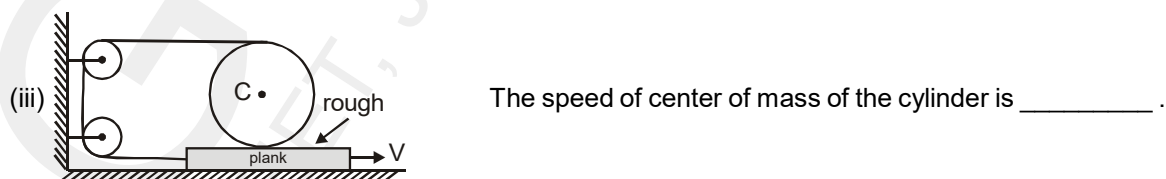
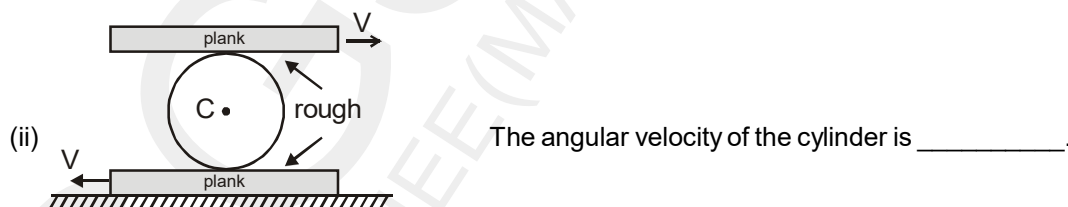
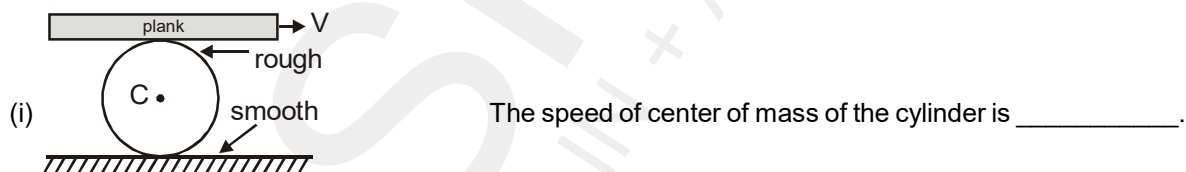

- (a)  $V$                       (b)  $V/R$                       (c)  $2V/R$                       (d)  $4V/R$   
 (e) cannot be determined from the given information  
 (f) Zero.  
 (A) (i) d (ii) b (iii) f (iv) c                      (B\*) (i) e (ii) b (iii) f (iv) c  
 (C) (i) e (ii) d (iii) f (iv) c                      (D) (i) e (ii) b (iii) f (iv) a

3. In a practical wheat stone bridge circuit as shown, when one more resistance of  $100\ \Omega$  is connected in parallel with unknown resistance 'x', then ratio  $l_1/l_2$  become '2'.  $l_1$  is balance length. AB is a uniform wire. Then value of 'x' must be:

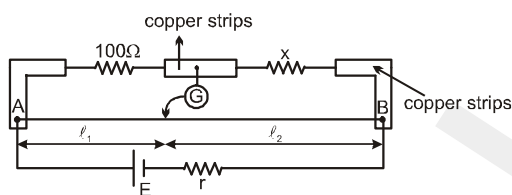

- (A)  $50\ \Omega$                       (B)  $100\ \Omega$                       (C)  $200\ \Omega$                       (D)  $400\ \Omega$

4. A parallel plate capacitor (without dielectric) is charged and disconnected from a battery. Now a dielectric is inserted between the plates. The electric force on a plate of the capacitor will:

- (A) decrease                      (B) increase  
 (C) remain same                      (D) depends on the width of the dielectric.

5. Assuming that the law of gravitation is of the form  $F = \frac{GMm}{r^3}$  and attractive. A body of mass m revolves in a circular path of radius r around a fixed body of mass M. Find on what power of r will the square of time period depend.

**COMPREHENSION**

Gravitational force is conservative and medium independent force. Its nature is attractive. Gravitational field and gravitational potential are related as.

$E_g = -\frac{\partial V}{\partial r}$  where  $E_g$  is component of gravitational field along 'r'. Since gravitational force is attractive so gravitational potential will always be zero or negative assuming potential to be zero at large distance. With help of above discussions answer the following questions.

6. A person brings mass of 1 kg from infinity to a point 'A'. Initially the mass was at rest but it moves with speed 2 m/s as it reaches A. If the work done by the person on the mass is  $-3\text{J}$ . The potential of A is :

- (A)  $-3\ \text{J/kg}$                       (B)  $+3\ \text{J/kg}$                       (C)  $-5\ \text{J/kg}$                       (D)  $5\ \text{J/kg}$

7. The gravitational potential inside a hollow sphere of mass M (uniformly distributed), radius R at a distance r from the centre is-

- (A) zero                      (B)  $-\frac{GM}{r}$                       (C)  $-\frac{GM}{R}$                       (D)  $-\frac{GM}{r^2}$

8. Gravitational potential V/s x graph is shown. The magnitude of field intensity is equal to

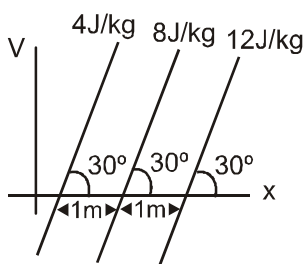

- (A)  $8\ \text{N/kg}$                       (B)  $4\ \text{N/kg}$   
 (C)  $6\ \text{N/kg}$                       (D)  $2\ \text{N/kg}$



3. In the figure shown  $P_1$  and  $P_2$  are two conducting plates having charges of equal magnitude and opposite sign. Two dielectrics of dielectric constant  $K_1$  and  $K_2$  fill the space between the plates as shown in the figure. The ratio of electrical energy in 1<sup>st</sup> dielectric to that in the 2<sup>nd</sup> dielectric is

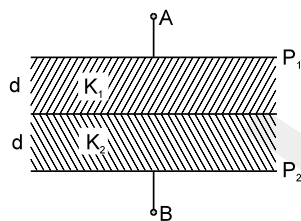

- (A) 1 : 1  
 (B)  $K_1 : K_2$   
 (C)  $K_2 : K_1$   
 (D)  $K_2^2 : K_1^2$

4. The gravitational potential energy of a satellite revolving around the earth in circular orbit is  $-4$  MJ. Find the additional energy (in MJ) that should be given to the satellite so that it escapes from the gravitational field of earth. Assume earth's gravitational force to be the only gravitational force on the satellite and no atmospheric resistance.
5. A uniform circular disc has radius  $R$  and mass  $m$ . A particle also of mass  $m$  is fixed at a point  $A$  on the periphery of the disc as shown in figure. The disc can rotate freely about a fixed horizontal chord  $PQ$  that is at a distance  $R/4$  from the centre  $C$  of the disc. The line  $AC$  is perpendicular to  $PQ$ . Initially the disc is held vertical with the point  $A$  at its highest position. It is then allowed to fall so that it starts rotating about  $PQ$ . Find the linear speed of the particle when it reaches its lowest position. Acceleration due to gravity is  $g$ .

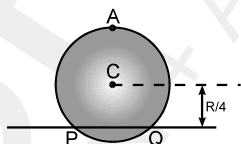

### COMPREHENSION

Two friends A and B (each weighing 40 kg) are sitting on a frictionless platform some distance  $d$  apart. A rolls a ball of mass 4 kg on the platform towards B which B catches. Then B rolls the ball towards A and A catches it. The ball keeps on moving back and forth between A and B. The ball has a fixed speed of 5 m/s on the platform.

6. Find the speed of A after he rolls the ball for the first time  
 (A) 0.5 m/s (B) 5m/s (C) 1 m/s (D) None of these
7. Find the speed of A after he catches the ball for the first time.  
 (A)  $\frac{10}{21}$  m/s (B)  $\frac{50}{11}$  m/s (C)  $\frac{10}{11}$  m/s (D) None of these
8. Find the speeds of A and B after the ball has made 5 round trips and is held by A :  
 (A)  $\frac{10}{11}$  m/s,  $\frac{50}{11}$  m/s (B)  $\frac{50}{11}$  m/s,  $\frac{10}{11}$  m/s (C)  $\frac{50}{11}$  m/s, 5 m/s (D) None of these
9. How many times can A roll the ball ?  
 (A) 6 (B) 5 (C) 7 (D) None of these
10. Where is the centre of mass of the system "A + B + ball" at the end of the  $n$ th trip? (Give the distance from the initial position of A)  
 (A)  $\frac{10}{11} d$  (B)  $\frac{10}{21} d$  (C)  $\frac{50}{11} d$  (D) None of these

**Topics : Current Electricity, Heat, Kinematics, Simple Harmonic Motion, Capacitance**

**Type of Questions**

Type of Questions	M.M., Min.
Single choice Objective ('-1' negative marking) Q.1 to Q.5	(3 marks, 3 min.) [15, 15]
Multiple choice objective ('-1' negative marking) Q.6	(4 marks, 4 min.) [4, 4]
Comprehension ('-1' negative marking) Q.7 to Q.9	(3 marks, 3 min.) [9, 9]

1. In the, Ohm's law experiment to find resistance of unknown resistor R, the arrangement is as shown.

The resistance measured is given by  $R_{\text{measured}} = \frac{V}{i}$ , V = voltage reading of voltmeter, i = current reading of ammeter. The ammeters and the voltmeter used are not ideal, and have resistances  $R_A$  and  $R_V$  respectively. For arrangement shown, the measured resistance is

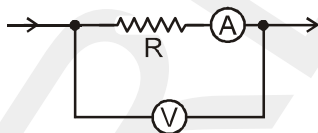

- (A)  $R + R_V$                       (B)  $R + R_A$                       (C)  $\frac{RR_V}{R + R_V}$                       (D)  $\frac{RR_V}{R + R_V} + R_A$

2. Two identical plates with thermal conductivities K and 3K are joined together to form a single plate of double thickness. The equivalent thermal conductivity of one composite plate so formed for the flow of heat through its thickness is:

- (A) K                      (B) 1.5 K                      (C) 2.5K                      (D) 3K

3. The acceleration time graph of a particle moving along a straight line is as shown in the figure. At what time the particle acquires its velocity equal to initial velocity ?

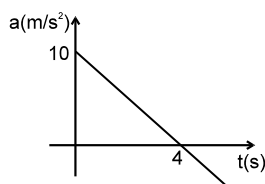

- (A) 12 sec                      (B) 5 sec  
 (C) 8 sec                      (D) none of these

4. As the distance between the plates of a parallel plate capacitor is decreased

(A) chances of electrical break down will increase if potential difference between the plates is kept constant.

(B) chances of electrical break down will decrease if potential difference between the plates is kept constant.

(C) chances of electrical break down will increase if charge on the plates is kept constant.

(D) chances of electrical break down will decrease if charge on the plates is kept constant.



**Topics : Heat, Simple Harmonic Motion, Current Electricity, Kinematics, Capacitance**

**Type of Questions**

Type of Questions	M.M., Min.
Single choice Objective ('-1' negative marking) Q.1 to Q.2	(3 marks, 3 min.) [6, 6]
Subjective Questions ('-1' negative marking) Q.3 to Q.4	(4 marks, 5 min.) [8, 10]
Comprehension ('-1' negative marking) Q.5 to Q.8	(3 marks, 3 min.) [12, 12]

- A wall has two layer A and B each made of different material, both the layers have the same thickness. The thermal conductivity of the material A is twice that of B. Under thermal equilibrium the temperature difference across the wall B is  $36^{\circ}\text{C}$ . The temperature difference across the wall A for the flow of heat through its thickness is  
 (A)  $6^{\circ}\text{C}$  (B)  $12^{\circ}\text{C}$  (C)  $18^{\circ}\text{C}$  (D)  $24^{\circ}\text{C}$
- If the length of a simple pendulum is doubled then the % change in the time period is :  
 (A) 50 (B) 41.4 (C) 25 (D) 100
- In the circuit shown, the reading of the ammeter (ideal) is the same with both switches open as with both closed. Find the value of resistance R in ohm.

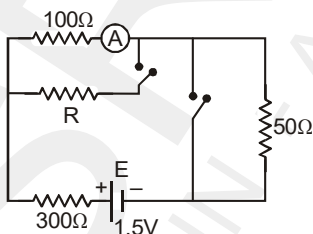

- A particle moves along X axis. At  $t = 0$  it was at  $x = -1$ . It's velocity varies with time as shown in the figure. Find the number of times the particle passes through the origin in  $t = 0$  to  $t = 10$  sec.

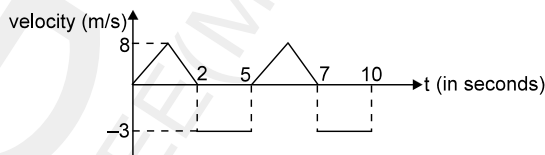

**COMPREHENSION**

The circuit contains ideal battery E and other elements arranged as shown. The capacitor is initially uncharged and switch S is closed at  $t = 0$ . (use  $e^2 = 7.4$ )

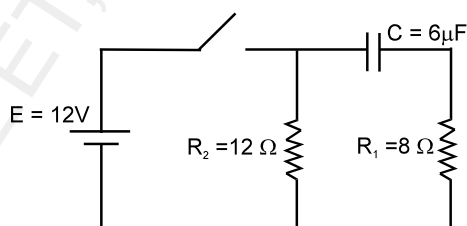

- Time constant of the circuit is  
 (A)  $48 \mu\text{s}$  (B)  $28.8 \mu\text{s}$  (C)  $72 \mu\text{s}$  (D)  $120 \mu\text{s}$
- The potential difference across the capacitor in volts, after two time constants, is approximately :  
 (A) 2 (B) 7.6 (C) 10.4 (D) 12
- The potential difference across resistor  $R_1$  after two time constants, is approximately :  
 (A) 1.6 V (B) 7.6 V (C) 10 V (D) 12 V
- The potential difference across resistor  $R_2$  after two time constants, is :  
 (A) 2V (B) 7.6V (C) 10V (D) 12 V

**Topics : Heat, Kinematics, Simple Harmonic Motion, Viscosity, Elasticity, Capacitance, Current Electricity**

**Type of Questions**

		<b>M.M., Min.</b>
Single choice Objective ('-1' negative marking) Q.1 to Q.5	(3 marks, 3 min.)	[15, 15]
Subjective Questions ('-1' negative marking) Q.6	(4 marks, 5 min.)	[4, 5]
Comprehension ('-1' negative marking) Q.7 to Q.8	(3 marks, 3 min.)	[6, 6]

1. All the rods have same conductance 'K' and same area of cross section 'A'. If ends A and C are maintained at temperature  $2T_0$  and  $T_0$  respectively then which of the following is/are correct:

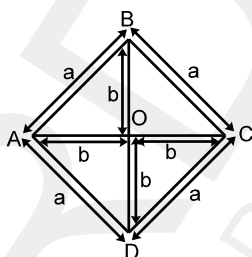

- (A) Rate of heat flow through ABC, AOC and ADC is same  
 (B) Rate of heat flow through BO and OD is not same  
 (C) Total Rate of heat flow from A to C is  $\frac{3KA T_0}{2a}$   
 (D) Temperature at junctions B, O and D are same
2. For which of the following graphs the average velocity of a particle moving along a straight line for time interval (0, t) must be negative -

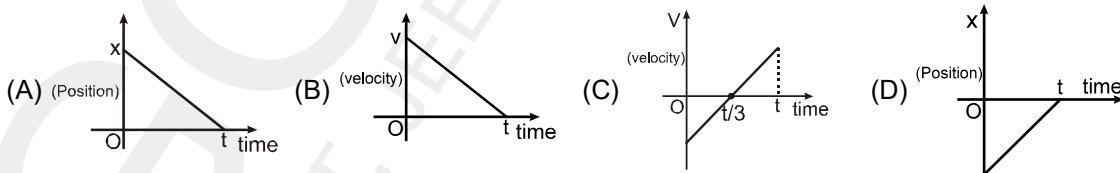

3. In the figure shown a block of mass  $m$  is attached at ends of two springs. The other ends of the spring are fixed. The mass  $m$  is released in the vertical plane when the spring are relaxed. The velocity of the block is maximum when:

- (A)  $k_1$  is compressed and  $k_2$  is elongated  
 (B)  $k_1$  is elongated and  $k_2$  is compressed  
 (C)  $k_1$  and  $k_2$  both are compressed  
 (D)  $k_1$  and  $k_2$  both are elongated.

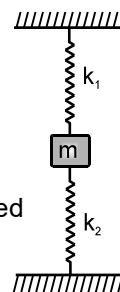

4. Rigidity modulus of steel is  $\eta$  and its young's modulus is  $Y$ . A piece of steel of cross-sectional area 'A' is changed into a wire of length  $L$  and area  $A/10$  then :
- (A)  $Y$  increases and  $\eta$  decrease  
 (B)  $Y$  and  $\eta$  remains the same  
 (C) both  $Y$  and  $\eta$  increase  
 (D) both  $Y$  and  $\eta$  decrease

5. A container filled with viscous liquid is moving vertically downwards with constant speed  $3v_0$ . At the instant shown, a sphere of radius  $r$  is moving vertically downwards (in liquid) has speed  $v_0$ . The coefficient of viscosity is  $\eta$ . There is no relative motion between the liquid and the container. Then at the shown instant, the magnitude of viscous force acting on sphere is

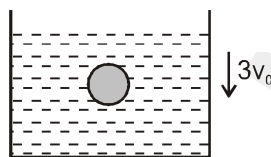

- (A)  $6\pi\eta r v_0$  (B)  $12\pi\eta r v_0$   
 (C)  $18\pi\eta r v_0$  (D)  $24\pi\eta r v_0$

6. Find the equivalent capacitance between terminals 'A' and 'B'. The letters have their usual meaning.

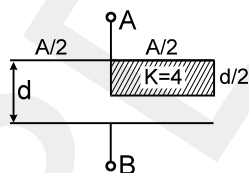

**COMPREHENSION**

A galvanometer measures current which passes through it. A galvanometer can measure typically current of order of mA. To be able to measure currents of the order of amperes of main current, a shunt resistance 'S' is connected in parallel with the galvanometer.

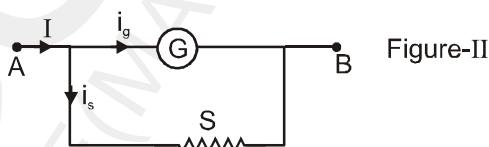

7. The resistance of the shunt 'S' and resistance 'G' of the galvanometer should have the following relation.  
 (A)  $S = G$  (B)  $S \gg G$  (C)  $S \ll G$  (D)  $S < G$
8. If resistance of galvanometer is  $10\Omega$  and maximum current  $i_g$  is  $10\text{mA}$  then the shunt resistance required so that the main current 'I' can be upto  $1\text{A}$  is (in  $\Omega$ )  
 (A)  $\frac{99}{10}$  (B)  $\frac{10}{99}$  (C)  $990$  (D)  $\frac{99}{1000}$



### COMPREHENSION

AB is a uniform wire of length 70 cm and resistance  $7\Omega$ . Part AC is 20 cm long. Two resistors and two ideal cells are connected as shown.

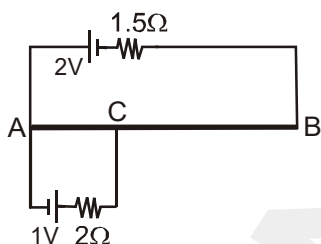

6. Potential gradient of the part CB of the wire is :
- (A)  $2.5\text{V/m}$  (B)  $2\text{V/m}$   
 (C)  $\frac{10}{3}\text{V/m}$  (D)  $7.5\text{V/m}$
7. Potential gradient of the part AC is :
- (A)  $\frac{5}{6}\text{V/m}$  (B)  $2\text{V/m}$   
 (C)  $5\text{V/m}$  (D)  $7.5\text{V/m}$
8. Of the points A, B and C the potential is maximum at point:
- (A) A (B) B  
 (C) C (D) same at all of these three points

**Topics : Heat, Work, Power and Energy, Rotation, Elasticity, Current Electricity**

**Type of Questions**

Type of Questions	M.M., Min.
Single choice Objective ('-1' negative marking) Q.1 to Q.3	(3 marks, 3 min.) [9, 9]
Multiple choice objective ('-1' negative marking) Q.4 to Q.5	(4 marks, 4 min.) [8, 8]
Comprehension ('-1' negative marking) Q.6 to Q.8	(3 marks, 3 min.) [9, 9]

- The energy radiated per unit area per sec. by a spherical black body will be doubled if its
 

(A) radius is increased by nearly 41.5%	(B) radius is doubled
(C) temp. (T) is increased by nearly 41.5%	(D) T is increased by nearly 19%.
- A body of mass 6 kg is acted upon by a force which causes a displacement in it given by  $x = \frac{t^2}{4}$  metre where t is the time in second. The work done by the force in 2 seconds is:
 

(A) 12 J	(B) 9 J
(C) 6 J	(D) 3 J
- In the figure shown, a small ball of mass 'm' can move without sliding in a fixed semicircular track of radius R in vertical plane. It is released from the top. The resultant force on the ball at the lowest point of the track is

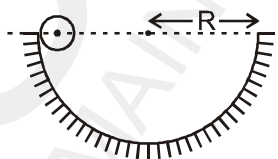

- |                      |                      |
|----------------------|----------------------|
| (A) $\frac{10mg}{7}$ | (B) $\frac{17mg}{7}$ |
| (C) $\frac{3mg}{7}$  | (D) zero             |
- An elastic rod will change its length, if
 

(A) the rod is suspended at one end
(B) The rod is allowed to fall freely under gravity
(C) the rod is rotated about one end on a frictionless horizontal table
(D) the rod is given a horizontal acceleration by a force applied at one end
  - A charged particle X moves directly towards another charged particle Y. For the 'X + Y' system, the total momentum is p and the total energy is E.
 

(A) p & E are conserved if both X & Y are free to move
(B) (A) is true only if X and Y have similar charges
(C) If Y is fixed, E is conserved but not p
(D) If Y is fixed, neither E nor p is conserved.

COMPREHENSION

Resistance value of an unknown resistor is calculated using the formula  $R = \frac{V}{I}$  where  $V$  and  $I$  be the readings of the voltmeter and the ammeter respectively. Consider the circuits below. The internal resistances of the voltmeter and the ammeter ( $R_V$  and  $R_G$  respectively) are finite and non zero.

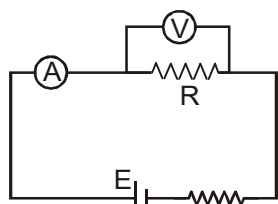

Figure (A)

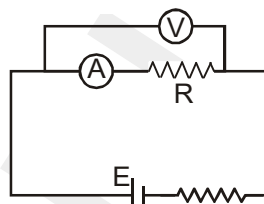

Figure (B)

Let  $R_A$  and  $R_B$  be the calculated values in the two cases A and B respectively.

6. The relation between  $R_A$  and the actual value  $R$  is  
 (A)  $R > R_A$  (B)  $R < R_A$   
 (C)  $R = R_A$  (D) dependent upon  $E$  and  $r$ .
7. The relation between  $R_B$  and the actual value  $R$  is :  
 (A)  $R < R_B$  (B)  $R > R_B$   
 (C)  $R = R_B$  (D) dependent upon  $E$  and  $r$ .
8. If the resistance of voltmeter is  $R_V = 1 \text{ k } \Omega$  and that of ammeter is  $R_G = 1 \Omega$ , the magnitude of the percentage error in the measurement of  $R$  (the value of  $R$  is nearly  $10 \Omega$ ) is :  
 (A) zero in both cases (B) non zero but equal in both cases  
 (C) more in circuit A (D) more in circuit B

## DPP 41 to 60 (ANSWER KEY)

### DPP NO. - 41

1. (B)    2. (C)    3. (A)    4. (B)  
 5.  $\sqrt{3/2}$     6. (D)    7. (C)    8. (C)

### DPP NO. - 42

1. (C)    2. (C)  
 3.  $v_1 = 30, v_2 = -25, v_3 = -35/3, v_4 = -25$  cm  
 4. 64    5. 4 radians    6. (B)  
 7. (C)(D)    8. (A)(B)(C)

### DPP NO. - 43

1. (B)    2. (C)    3. (A)(C)    4. 1  
 5.  $\frac{9r}{10}$     6. (B)    7. (A)    8. (C)

### DPP NO. - 44

1. (C)    2. (A)    3. (A)(C)    4. 8000  
 5. (C)    6. (C)    7. (B)  
 8. (A) p,r (B) q,r (C) q,r (D) q,r

### DPP NO. - 45

1. (A)    2. (B)    3. 8    4.  $x = 5$   
 5. (B)    6. (A)    7. (C)  
 8. (A) - q,t; (B) - p,r,s; (C) - p,r,s; (D) - q,r,t

### DPP NO. - 46

1. (C)    2. (D)    3. (B)    4. (C)  
 5. (B)    6. (A)    7. (C)  
 8. (A) - p,q,s, (B) - r, (C) - r,t; (D) - p,q,s,t.

### DPP NO. - 47

1. (D)    2. (C)    3. (D)    4. (A)  
 5. (C)    6. (A)    7. (A)    8. (C)

### DPP NO. - 48

1. (C)    2. (A)    3. (A,C)    4. (B)  
 5. (A)    6. (C)    7. (C)    8. (A)

### DPP NO. - 49

1. (B)    2. (C)    3. (A)    4. (B)  
 5.  $t_1 > t_2$     6. (C)    7. (A)    8. (C)

### DPP NO. - 50

1. (B)    2. (A)    3. (A)    4.  $\omega = \sqrt{\frac{9g}{4\ell}}$   
 5. Flag will flutter in south direction.    6. (C)  
 7. (D)    8. (C)

### DPP NO. - 51

1. (A)    2. (D)    3. (A)    4. (A)(C)(D)  
 5. (B)    6. (C)    7. (C)    8. (D)

### DPP NO. - 52

1. (B)    2. (C)    3. (A)    4. (A)  
 5.  $V_{AB} = \frac{\epsilon}{(1+3\eta+\eta^2)} = 10V$     6. (A)  
 7. (C)    8. (A)

### DPP NO. - 53

1. (B)    2. (C)    3. (B)(C)    4. 3000  
 5.  $R = r$     6. (B)    7. (B)    8. (A)

### DPP NO. - 54

1. (A)    2. (B)    3. (B)    4. (C)  
 5. 04    6. (C)    7. (C)    8. (A)

### DPP NO. - 55

1. (B)    2. (A)    3. (C)    4. 2  
 5.  $v = \sqrt{5gR}$     6. (A)    7. (C)  
 8. (C)    9. (A)    10. (B)

### DPP NO. - 56

1. (B)    2. (B)    3. (C)    4. (A)  
 5. (B)    6. (B,D)    7. (D)    8. (B)  
 9. (C)

### DPP NO. - 57

1. (C)    2. (B)    3. 600    4. 4 times  
 5. (A)    6. (C)    7. (A)    8. (D)

### DPP NO. - 58

1. (D)    2. (A)    3. (B)    4. (B)  
 5. (B)    6.  $\frac{13 \epsilon_0 A}{10 d}$     7. (C)  
 8. (B)

### DPP NO. - 59

1. (C)    2. (D)    3. (A)    4. (A)(C)  
 5. (A)(C)    6. (C)    7. (A)    8. (C)

### DPP NO. - 60

1. (D)    2. (D)    3. (A)    4. (A)(C)(D)  
 5. (A)(C)    6. (A)    7. (A)    8. (D)



# GGSRDN

Educational Services Private Limited

9<sup>th</sup>, 10<sup>th</sup>, NEET, JEE(Main/Advanced)

अभ्यास ही सबसे बड़ा गुरु है।

**CLASS : XII (PHYSICS)**

# D P P P

**DAILY PRACTICE PROBLEM**

*Solutions*

**DPP- 41 to 60**

**DPP NO. - 40**

1. Upward force by capillary tube on top surface of liquid is

$$f_{up} = 4\sigma a \cos \theta$$

If liquid is raised to a height  $h$  then we use

$$4\sigma a \cos \theta = ha^2 \rho g$$

$$\text{or } h = \frac{4\sigma \cos \theta}{a\rho g} \quad \text{Ans.}$$

2.  $\Delta l = \frac{Fl}{\pi r^2 y} \Rightarrow \Delta l \propto \frac{l}{r^2}$

Only option 'radius 3mm, length 2m' is satisfying the above relation.

3. Velocity gradient =  $\frac{0.5}{2.5 \times 10^{-2}}$

as force on the plate due to viscosity is from upper as well as lower portion of the oil, equal from each part,

$$\text{Then, } F = 2\eta A \frac{dv}{dz}$$

$$= 2 \times \eta \times (0.5) \frac{0.5}{1.25 \times 10^{-2}}$$

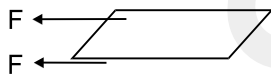

$$\Rightarrow \eta = 2.5 \times 10^{-2} \text{ kg - sec/m}^2$$

4.

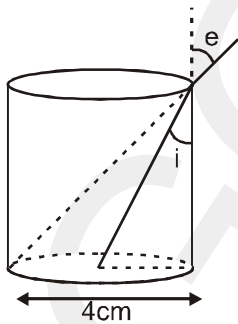

$$\sqrt{\frac{5}{2}} \sin i = 1 \sin e \Rightarrow \sqrt{\frac{5}{2}} \frac{2\text{cm}}{\sqrt{4\text{cm}^2 + h^2}}$$

$$= 1 \times \frac{4\text{cm}}{\sqrt{16\text{cm}^2 + h^2}} \Rightarrow h = 4\text{cm}$$

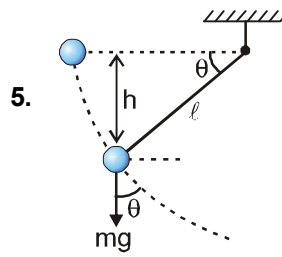

5.

From conservation of energy

$$mgh = \frac{1}{2} mv^2$$

$$\Rightarrow mgl \sin \theta = \frac{1}{2} mv^2$$

$$\Rightarrow 2g \sin \theta = \frac{v^2}{l} = a_c$$

$$g \cos \theta = a_t$$

$$\text{Total acceleration } a = \sqrt{a_c^2 + a_t^2}$$

$$= g\sqrt{\cos^2 \theta + (2\sin \theta)^2} = g\sqrt{3\sin^2 \theta + 1}$$

6.  $\mu = \frac{3.2\text{g}}{40\text{cm}} = \frac{3.2 \times 10^{-3}}{40 \times 10^{-2}} = \frac{3.2}{40} = \frac{32}{4000} \text{ kg/m}$

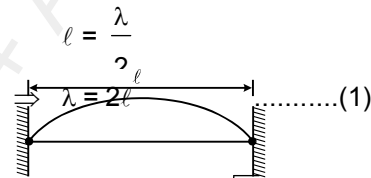

$$f = \frac{v}{\lambda} = \frac{1}{2l} \sqrt{\frac{T}{\mu}}$$

$$\Rightarrow \frac{1000}{64} = \frac{1}{2 \times 40 \times 10^{-2}} \sqrt{\frac{T}{32/4000}}$$

$$\Rightarrow \left[ \frac{1000}{64} \times 2 \times 40 \times 10^{-2} \right]^2 \frac{32}{4000} = T$$

$$\frac{1000}{64} \times \frac{32}{4000} = T$$

$$\Rightarrow T = \frac{10}{8} \text{ N}$$

$$\text{अब } y = \frac{\frac{10/8}{10^{-6}}}{\frac{.05 \times 10^{-2}}{40 \times 10^{-2}}} = \frac{10^7}{8} \frac{40}{(.05)}$$

$$= 10^9 \text{ N/m}^2. \quad \text{[ Ans. } 1 \times 10^9 \text{ N/m}^2 \text{ ]}$$

7. Torque of friction about A is zero.

8. Angular momentum conservation about point A.

$$L_{in} = mv_0 r - mk^2 \omega_0$$

$$L_{fin} = 0$$

$$L_{fin} = L_{in}$$

$$\Rightarrow v_0 = \omega_0 k^2 / r.$$

9.  $a_{cm} = -\mu g$

$$0^2 = v_0^2 - 2\mu g s \Rightarrow s = \frac{v_0^2}{2\mu g}$$

### DPP NO. - 41

1. (B)  $V_B > V_D$  In a Wheatstone's bridge circuit shown if  $PS = QR$ ,  $V_B = V_D$ . No current flows between B and D.

If  $PS < QR$ ,  $V_B > V_D$  current flows from B to D.

If  $PS > QR$ ,  $V_B < V_D$  current flows from D to B.

**Alternate :**

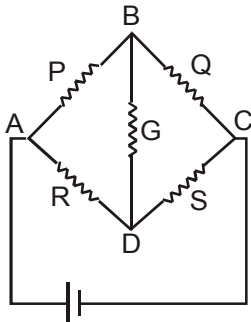

Let resistance  $P = 0$  and all other resistances  $Q, R, S, G$  are non-zero then  $PS < QR$  condition is satisfied.

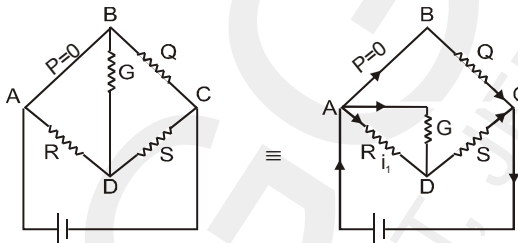

$$V_A = V_B$$

$$\Rightarrow V_A - i_1 R = V_D$$

$\Rightarrow V_A - V_D = i_1 R = \text{positive}$  (or current flows from A to D through G, then  $V_A > V_D$ )

$$\Rightarrow V_A > V_D$$

$$\Rightarrow V_B > V_D$$

Let resistance  $S = 0$  and all other resistances  $P, Q, R, G$  are non-zero then  $PS < QR$  condition is also satisfied.

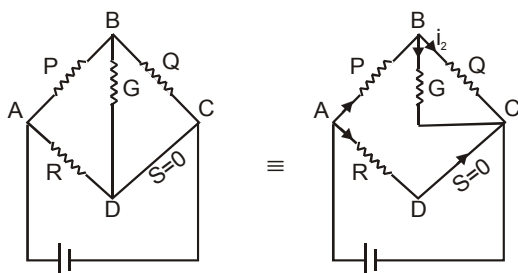

$$V_D = V_C$$

$$\Rightarrow V_B - i_2 Q = V_C = V_D$$

$$\Rightarrow V_B - V_D = i_2 Q = \text{positive}$$

$$\Rightarrow V_B > V_D$$

Suppose resistance  $Q$  is zero and all other resistances  $P, R, S, G$  are non-zero then  $PS > QR$ .

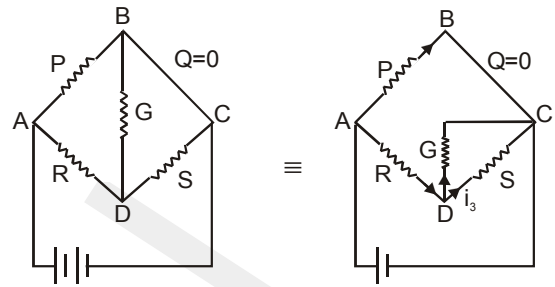

$$V_B = V_C$$

$$V_D - V_C = i_3 S = \text{positive}$$

$$\Rightarrow V_D > V_C$$

$$\Rightarrow V_D > V_B$$

If resistance  $R$  is zero and all other resistances are non-zero, then  $PS > QR$  and similarly, we get  $V_D > V_B$ . Hence if  $PS < QR$ ,  $V_B > V_D$ .

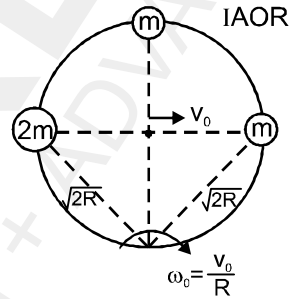

2.

$$K.E._{system} = \frac{1}{2} \times 2 m R^2 \omega_0^2 + \frac{1}{2} m (2R)^2 \omega_0^2 +$$

$$\frac{1}{2} m (\sqrt{2} R)^2 \omega^2 + \frac{1}{2} 2m (\sqrt{2} R)^2 \omega_0^2$$

$$= 6 m v_0^2$$

$$K.E._{2m} = \frac{1}{2} \times 2m (\sqrt{2} R)^2 \omega^2 = 2m v_0^2.$$

3.  $a = \frac{2T\ell}{m}$

$$v = u + at \Rightarrow 0 = u - at$$

$$t = \frac{u}{a} = \frac{um}{2T\ell}$$

$$\text{Total time } T = 2t = \frac{um}{T\ell}.$$

4. According to given condition,

$$\frac{13v}{4\left(\frac{\ell}{2} + e\right)} = \frac{7v}{2\left(\frac{\ell}{2} + 2e\right)}$$

$$e = \frac{\ell}{24} \quad \text{So, } r = \frac{10e}{6} \quad r = \frac{5\ell}{72}$$

5. For TIR at B, the angle of incidence  $i > c$

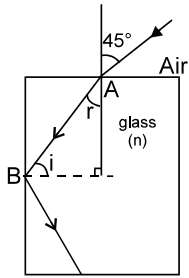

$$\& r + i = 90 \Rightarrow i = 90 - r$$

by snell's law at pt A,

$$\sin 45^\circ = n \sin r = n \cos i$$

$$\text{Now } \therefore i > c \Rightarrow \sin i > \sin c$$

$$\Rightarrow \cos r > \frac{1}{n}$$

$$\Rightarrow n > \frac{1}{\cos r}$$

$$\Rightarrow n > \frac{1}{\sqrt{1 - \sin^2 r}}$$

$$\Rightarrow n > \frac{1}{\sqrt{1 - \frac{1}{2n^2}}}$$

$$\Rightarrow n > \frac{\sqrt{2} n}{\sqrt{2n^2 - 1}}$$

$$\Rightarrow 2n^2 - 1 > 2 \Rightarrow n > \sqrt{\frac{3}{2}}$$

6. The time in which the planet rotates about its axis is not given for either planet.

7. For geostationary satellite, time period = 1 planet day (by def.)

Let  $T = 1$  planet day

$T_0 = 1$  planet year

$$\text{Now } T^2 = \frac{4\pi^2}{Gm} r_G^3 = \frac{4\pi^2}{Gm} r^3 \left( \frac{m}{M} \right)$$

$$= \frac{4\pi^2}{GM} r^3 = T_0^3 \Rightarrow T = T_0$$

8. The energy of any geostationary satellite is the sum of kinetic energy of satellite, interaction energy of satellite and its own planet and interaction energy of satellite and star. Both planets have same mass and same length of day. Geostationary satellite - planet system will have same interaction energy in either planet. Also kinetic energy of both satellites will be same. But the satellite-sun system will account for the energy difference.

$$U_i = -\frac{GMm_0}{2r} + U_{\text{satellite - planet}}$$

$$U_f = -\frac{GMm_0}{2(4r)} + U_{\text{satellite - planet}}$$

$$E_{\text{min}} = U_f - U_i = \frac{3GMm_0}{8r}$$

### DPP NO. - 42

1. In a binary star system

$$\omega_1 = \omega_2$$

2. Strain ( $\epsilon$ ) =  $\frac{\Delta \ell}{\ell} = \infty \Delta T = (10^{-5})(200)$

$$= 2 \times 10^{-3}$$

Stress =  $Y$  (strain)

$$\text{Stress} = 10^{11} \times 2 \times 10^{-3} = 2 \times 10^8 \text{ N/m}^2$$

$\Rightarrow$  Required force = stress  $\times$  Area

$$= (2 \times 10^8) (2 \times 10^{-6}) = 4 \times 10^2 = 400 \text{ N}$$

$$\therefore \text{Mass to be attached} = \frac{400}{g} = 40 \text{ kg}$$

3. [Ans.  $v_1 = 30, v_2 = -25, v_3 = -35/3, v_4 = -25 \text{ cm}$ ]

4. Ans. 64

$$I = \frac{p^2}{\rho v}$$

$$\frac{I_2}{I_1} = \frac{\rho_2^2}{\rho_1^2} \times \frac{\rho_1}{\rho_2} \times \frac{v_1}{v_2}$$

$$= \frac{9}{16} \times \frac{1.5}{3} \times \frac{400}{1200} = \frac{9}{16 \times 3 \times 2} = \frac{3}{32}$$

$$6 \frac{I_1}{I_2} = \frac{6 \times 32}{3} = 64$$

5. By energy conservation,

$$mg \cdot \frac{3l}{2} = \frac{1}{2} \cdot \frac{m(3l)^2}{3} \cdot \omega^2$$

$$\omega = \sqrt{\frac{g}{l}}$$

and velocity of centre of mass of rod BC

$$V_{cm} = \sqrt{\frac{g}{l}} \cdot 2l$$

$$V_{cm} = 2\sqrt{gl}$$

If time taken by centre of mass of rod BC from breaking position to line PQ is t.

$$8l = \frac{1}{2} \times g \times t^2$$

$$t = 4\sqrt{\frac{l}{g}}$$

$$\theta = \omega \cdot t = 4 \text{ radian.}$$

6.  $iR = \phi$  (58.3)

$$\& iX = \phi$$
 (68.5)

where  $\phi$  is the potential gradient of the potentiometer

$$\therefore \frac{R}{X} = \frac{58.3}{68.5}$$

$$\frac{10}{X} = \frac{58.3}{68.5} \Rightarrow X = 11.75 \Omega$$

7. The maximum P.D. which we can measure by this potentiometer is V

8. Any change can be done which assures p.d. across R or X less than or equal to V

### DPP NO. - 43

1. Originally

$$V_A = V_D = V_E$$

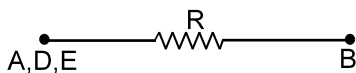

After connecting C & B. The equivalent circuit will be  
 [Now  $V_A = V_D = V_E$  and  $V_C = V_B$ ]

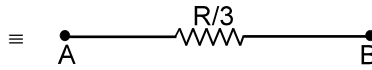
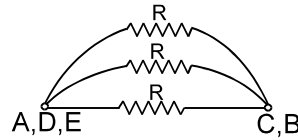

$\therefore$  Ratio = 3.

2. The only force acting on the body is the viscous force

$$\text{Here, } m \frac{dv}{dx} = -6\pi\eta rv$$

$$= -rv$$

$$\Rightarrow \int_v^0 m dv = \int_0^x -r dx \Rightarrow x = \frac{mv}{r}$$

3. The image of a point closer to the focus will be farther. As the transverse magnification of B will be more than A, the image of AB will be inclined to the optical axis.

$$4. a_1 = \frac{F}{m} = \frac{GM}{r^2}$$

It is same in both cases

$$\therefore \frac{a_1}{a_2} = 1$$

5. Loudness  $\beta = 10 \log_{10} \frac{I}{I_0}$

$$\therefore \beta_2 - \beta_1 = 10 \log_{10} \frac{I_2}{I_1} \quad \&$$

$$\therefore I = \frac{P}{4\pi r^2}$$

$$\therefore \frac{I_2}{I_1} = \frac{r_1^2}{r_2^2}$$

$$\therefore (\beta + 20) - \beta = 10 \log_{10} \frac{r^2}{r_2^2}$$

$$= 20 \log_{10} \frac{r}{r_2}$$

$$\Rightarrow \frac{r}{r_2} = 10 \Rightarrow r_2 = 0.1r$$

$$\therefore \text{shift} = r - 0.1r = 0.9r$$

$$\text{Ans. } \frac{9r}{10}$$

**Sol. 6 to 8**

The angular speed of rod =  $\omega = \frac{u - v_B}{l/2}$

As given  $v_B = 0 \quad \therefore \omega = \frac{2u}{l}$  **Ans.**

The time after which centre of rod reaches the highest point is  $t_0 = \frac{u}{g}$

The angular acceleration of rod is zero and in the given time to the rod undergoes angular displacement

$$\frac{\pi}{2}$$

$\therefore$  from  $\theta = \omega t$

$$\Rightarrow \frac{\pi}{2} = \frac{2u}{l} \times \frac{u}{g} \quad \text{or} \quad u = \sqrt{\frac{\pi g L}{4}}$$

**DPP NO. - 44**

1. By energy conservation between A & B

$$\Rightarrow Mg \frac{2R}{5} + 0 = \frac{MgR}{5} + \frac{1}{2} MV^2$$

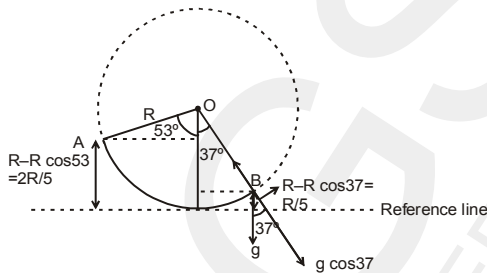

$$V = \sqrt{\frac{2gR}{5}}$$

Now, radius of curvature  $r$

$$= \frac{V_{\perp}^2}{a_r} = \frac{2gR/5}{g \cos 37} = \frac{R}{2}$$

$$r = \frac{V_{\perp}^2}{a_r} = \frac{2gR/5}{g \cos 37} = \frac{R}{2}$$

2. Relative displacement of glass window w.r.t. cyclist is 20 cm time taken = 1 sec.

So, relative velocity of glass window w.r.t. cyclist =

$$\frac{20}{1} \text{ cm/sec.} = 0.2 \text{ m/sec.}$$

3.  $a = 3t^2 + 1$

$$\frac{dv}{dt} = 3t^2 + 1 \Rightarrow \int_0^v dv = \int_0^1 (3t^2 + 1) dt$$

$$v = (t^3 + t)_0^1 = 2 \text{ m/s.}$$

$$\Rightarrow v = t^3 + t$$

$$\therefore \int_0^s ds = \int_0^1 (t^3 + t) dt$$

$$\Rightarrow S = \frac{1}{4} + \frac{1}{2} = 0.75$$

4. 8000

Conserving angular momentum  $m.(V_1 \cos 60^\circ)$ .

$$4R = m.V_2.R \quad ; \quad \frac{V_2}{V_1} = 2.$$

Conserving energy of the system

$$m.(V_1 \cos 60^\circ). 4R = m.V_2.R \quad ; \quad \frac{V_2}{V_1} = 2.$$

$$-\frac{GMm}{4R} + \frac{1}{2} m V_1^2 = -\frac{GMm}{R} + \frac{1}{2} m V_2^2$$

$$\frac{1}{2} V_2^2 - \frac{1}{2} V_1^2 = \frac{3}{4} \frac{GM}{R}$$

$$\text{or} \quad V_1^2 = \frac{1}{2} \frac{GM}{R}$$

$$V_1 = \frac{1}{\sqrt{2}} \sqrt{64 \times 10^6} = \frac{8000}{\sqrt{2}} \text{ m/s} \quad \text{Ans. 8000}$$

7. On the positive side of x axis, potential is zero at distance  $x_1$  (it is between both charges), then

$$\frac{k.6e}{r} = \frac{k.10e}{8-r} \Rightarrow r = 3 \text{ nm}$$

For the left side

$$\frac{k.6e}{x_2} = \frac{k.10e}{8+x_2}$$

$$\Rightarrow x_2 = 12 \text{ nm}$$

$$R = \frac{x_1 + x_2}{2} = 7.5 \text{ nm}$$

$$|X_c| = X_2 - R = 4.5 \text{ nm}$$

$$V_c = \frac{k.6e}{4.5 \times 10^{-9}} - \frac{k.10e}{12.5 \times 10^{-9}}$$

$$= 9 \times 10^9 \times 10^9 \times 1.6 \times 10^{-19} \left[ \frac{4}{3} - \frac{4}{5} \right] = 1.44 \times \frac{8}{15}$$

$$= 0.77 \text{ V}$$

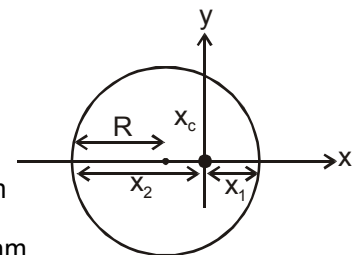

8. (A) p, r (B) q, r (C) q, r (D) q, r

Initially the image is formed at infinity.

(A) As  $m$  is increased the focal length decreases. Hence the object is at a distance larger than focal length. Therefore final image is real. Also final image becomes smaller in size in comparison to size of image before the change was made.

(B) If the radius of curvature is doubled, the focal length decreases. Hence the object is at a distance lesser than focal length. Therefore final image is virtual. Also final image becomes smaller in size in comparison to size of image before the change was made.

(C) Due to insertion of slab the effective object for lens shifts right wards. Hence final image is virtual. Also final image becomes smaller in size in comparison to size of image before the change was made.

(D) The object comes to centre of curvature of right spherical surface as a result. Hence the final image is virtual. Also final image becomes smaller in size in comparison to size of image before the change was made.

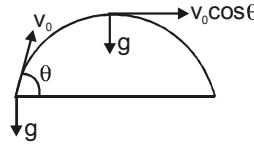
$$3. R_1 = \frac{v_0^2}{g \cos \theta}$$

$$R_2 = \frac{(v_0 \cos \theta)^2}{g}$$

$$\therefore \frac{R_1}{R_2} = \frac{1}{(\cos \theta)^3} = 8 \quad \text{Ans. 8}$$

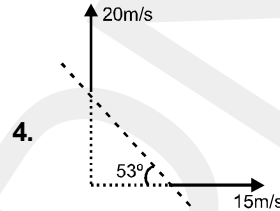

$$f' = \left( \frac{334 - 9}{334 + 16} \right) 700 = \frac{325}{350} \times 700 = 650 \text{ Hz.}$$

5. Consider two small elements of ring having charges  $+dq$  and  $-dq$  symmetrically located about  $y$ -axis. The potential due to this pair at any point on  $y$ -axis is zero. The sum of potential due to all such possible pairs is zero at all points on  $y$ -axis.

Hence potential at  $P(0, \frac{R}{2})$  is zero.

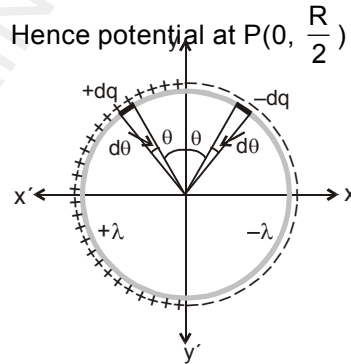

6. Since all charge lies in  $x$ - $y$  plane, hence direction of electric field at point  $P$  should be in  $x$ - $y$  plane. Also  $y$ -axis is an equipotential (zero potential) line. Hence direction of electric field at all point on  $y$ -axis should be normal to  $y$ -axis.  $\therefore$  The direction of electric field at  $P$  should be in  $x$ - $y$  plane and normal to  $y$ -axis. Hence direction of electric field is along positive- $x$  direction.

7. Consider two small elements of ring having charge  $+dq$  and  $-dq$  as shown in figure. The pair constitutes a dipole of dipole moment.  $dp = dq \cdot 2R = (\lambda R d\theta) \cdot 2R$ . The net dipole moment of system is vector sum of dipole moments of all such pairs of elementary charges.

### DPP NO. - 45

1. The linear relationship between  $V$  and  $x$  is  $V = -mx + C$  where  $m$  and  $C$  are positive constants.

$\therefore$  Acceleration

$$a = v \frac{dv}{dx} = -m(-mx + C)$$

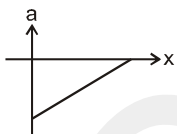

$$\therefore a = m^2x - mC$$

Hence the graph relating  $a$  to  $x$  is.

2. Relative to lift initial velocity and acceleration of coin are  $0 \text{ m/s}$  and  $1 \text{ m/s}^2$  downward

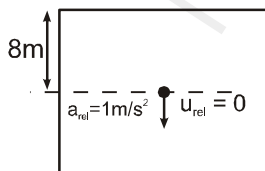

$$\therefore 2 = \frac{1}{2}(1) t^2 \text{ or } t = 2 \text{ second}$$

By symmetry the resultant dipole moment is

along negative x-direction.

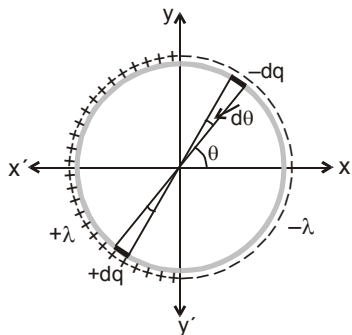

∴ net dipole moment

$$= - \int_{-\pi/2}^{+\pi/2} (dp \cos \theta) \hat{i} = - \int_{-\pi/2}^{+\pi/2} (2\lambda R^2 \cos \theta d\theta) \hat{i}$$

$$= -4R^2 \lambda \hat{i}$$

8. (A)  $\frac{1}{f} = \underbrace{\left(\frac{n_l}{n_s} - 1\right)}_{-} \underbrace{\left(\frac{1}{R_1} - \frac{1}{R_2}\right)}_{+}$

$f = -ve$

$P = \frac{1}{f} = -ve$  q,t

(B)  $\frac{1}{f} = \underbrace{\left(\frac{n_l}{n_s} - 1\right)}_{+} \underbrace{\left(\frac{1}{R_1} - \frac{1}{R_2}\right)}_{+}$

$f = +ve$

$P = \frac{1}{f} = +ve$  p,r,s

(C)  $\frac{1}{f} = \underbrace{\left(\frac{n_l}{n_s} - 1\right)}_{-} \underbrace{\left(\frac{1}{R_1} - \frac{1}{R_2}\right)}_{-}$

$f = +, P = \frac{1}{f} = +ve$  p,r,s

(D)  $f = \frac{R}{2}$

$P = \frac{1}{f} = -ve$  r,q,t

**DPP NO. - 46**

1. The electric field intensity due to each uniformly charged infinite plane is uniform. The electric field intensity at points A, B, C and D due to plane 1, plane 2 and both planes are given by  $E_1, E_2$  and  $E$  as shown in figure 1. Hence the electric lines of forces are as given in figure 2.

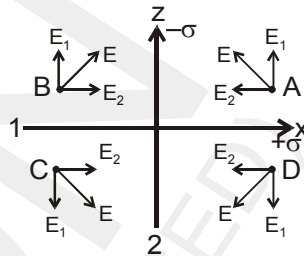

(figure 1)

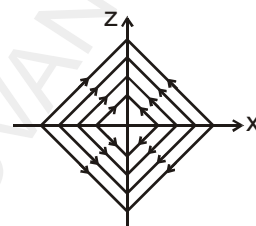

(figure 2)

**Aliter :** Electric lines of forces originate from positively charged plane and terminate at negatively charged plane. Hence the correct representation of ELOF is as shown figure 2.

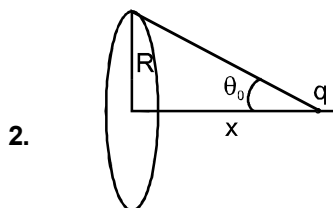

Force on  $q = Eq = \frac{\sigma}{2\epsilon_0} (1 - \cos \theta_0) q = f$

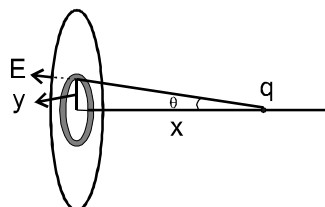

Consider a ring of radius  $y$  and thickness  $dy$ . Flux through this ring  $d\phi = (E \cos \theta) 2\pi y dy$

∴ Total flux =  $\int_0^{\theta_0} \frac{1}{4\pi\epsilon_0} \frac{q}{r^2} 2\pi y dy \cos \theta$

$$= \frac{q}{2\epsilon_0} (1 - \cos \theta_0)$$

$$\text{So, } \phi = \frac{f}{\sigma}$$

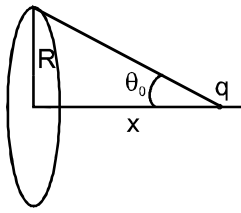

3. (Moderate)  $a = v \frac{dv}{dx} = cx + d$

Let at  $x = 0$   $v = u$

$$\therefore \int_u^v v dv = \int_0^x (cx + d) dx$$

$$\text{or } v^2 = cx^2 + 2dx + u^2$$

$v$  shall be linear function of  $x$  if  $cx^2 + 2dx + u^2$  is perfect square

4. (C)

Velocity of approach of P and O is

$$-\frac{dx}{dt} = v \cos 60^\circ = 5 \text{ m/s}$$

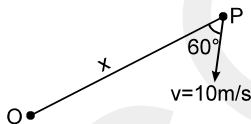

It can be seen that velocity of approach is always constant.

$$\therefore \text{P reaches O after} = \frac{100}{5} = 20 \text{ sec.}$$

5.  $a = (kx - f)/m$

$$f \times R = mR^2 / 2 \times a/R$$

6. by energy conservation

$$\frac{1}{2} \times 20 \times 0.3 \times 0.3 = \frac{1}{2} \times \frac{mR^2}{2} \times \frac{v^2}{R^2} + \frac{1}{2} mv^2$$

$$mv^2 = 1.2 \text{ J}$$

$$\text{Rotational K.E.} = \frac{mv^2}{4} = 0.3 \text{ J}$$

7. by energy conservation

$$\frac{1}{2} \times 20 \times 0.3 \times 0.3 = \frac{1}{2} \times \frac{mR^2}{2} \times \frac{v^2}{R^2} + \frac{1}{2} mv^2$$

$$mv^2 = 1.2 \text{ J}$$

$$\text{Translation K.E.} = \frac{mv^2}{2} = 0.6 \text{ J}$$

8. (A) – p,q,s, (B) – r, (C) – r,t; (D) – p,q,s,t.

(p) Parallel beam can be obtained from concave mirror and convex lens when point object is at focus.

(q) Real image for real object is for concave mirror and convex lens.

(r) Virtual and diminished images are obtained for convex mirror and concave lens.

(s) Real and magnified image is obtained for concave mirror and convex lens.

(t) The direction of motion of image is in the same direction as motion of object in lens and opposite in mirror.

### DPP NO. - 47

1. As seen from the figure

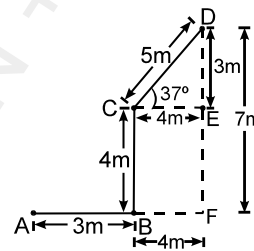

the displacement is  $\sqrt{(AF)^2 + (FD)^2}$

$$= 7\sqrt{2} \text{ m}$$

2. Max. frictional force

$$f_{\max} = \mu N$$

$$= \mu(mg + F \sin 53^\circ)$$

$$= 0.2 (20 \times 10 + 30 \times \frac{4}{5})$$

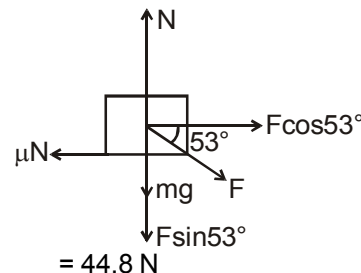

As applied horizontal force is  $F \cos 53^\circ$   
 $= 18 \text{ N} < f_{\max}$ , friction force will also be 18 N.

3. Potential gradient = 1.6 v/m  
 E.M.F. = potential gradient × balancing length  
 $1.2 = 1.6 \times \ell$   
 $\therefore \ell = \frac{1.2}{1.6} = \frac{3}{4} = 0.75 \text{ m} = 75\text{cm}$

4.  $mg = m\omega^2 R$ ,  $\omega = \sqrt{\frac{g}{R}}$

6.  $\frac{KQ}{x^2} = \frac{K4Q}{(3r-x)^2}$  (Since  $r \gg R$ )  
 $\Rightarrow (3r-x) = 2r$   
 $\Rightarrow x = r$

7. Once the charge reaches the neutral point it will be accelerated towards center of ring 2, will cross it, be reatarded, come to rest and then return towards it. Thus the motion is oscillatory, but not SHM.

8.  $U_{in} = \frac{4KQq}{R} + \frac{KQq}{3r}$

Its energy when it reaches the center of ring 1

$U_{fin.} = \frac{KQq}{R} + \frac{4KQq}{3r} + \text{K.E.} = U_{in}$

$\Rightarrow$  K.E. is positive

**DPP NO. - 48**

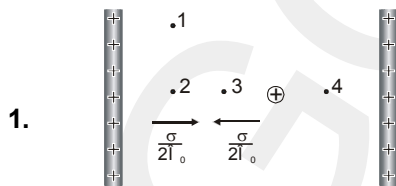

1. Electric field due to both the plates will be cancelled out for all the points. So the net electric field at the points will be governed only by the sphere. Farther the point from the sphere, lesser the magnitude of electric field.  
 Therefore  $E_3 = E_4 > E_2 > E_1$

2. Since the block slides down the incline with uniform velocity, net force on it must be zero. Hence  $mg \sin\theta$  must balance the frictional force 'f' on the block.  
 Therefore  $f = mg \sin\theta = 5 \times 10 \times \frac{1}{2} = 25 \text{ N}$ .

**DPP NO. - 49**

1. Four lines, perpendicular to lines of electric field and passing through A, B, C and D are drawn. These are equipotential lines. As potential decreases in the direction of electric field, therefore  $V_A > V_B > V_D > V_C$

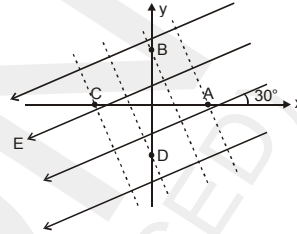

2. For A,  $\frac{ds}{dt} = V_A = \frac{1}{\sqrt{3}}$

For B,  $\frac{ds}{dt} = V_B = \sqrt{3}$

$\frac{V_A}{V_B} = \frac{1}{3}$

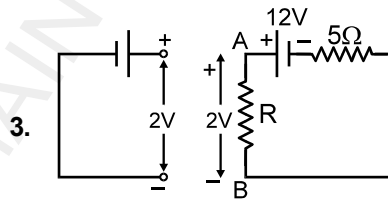

3. If pot. drop between A and B is also 2V, then no current will pass through the gelvanomter.

Pot. drop across R =  $\left(\frac{12}{R+5}\right)R = 2$

$12R = 2R + 10$   
 $R = 1 \Omega$

4. Let the angular speed of disc when the balls reach the end be  $\omega$ .  
 From conservation of angular momentum

$\frac{1}{2} mR^2 \omega_0 = \frac{1}{2} mR^2 \omega + \frac{m}{2} R^2 \omega + \frac{m}{2} R^2 \omega$

or  $\omega = \frac{\omega_0}{3}$

5. In second case due to psuedo force acting on the block its acceleration will be more as compared to the first case.

Hence  $t_1 > t_2$

**Ans.**  $t_1 > t_2$

- $V = E + ir$  (during charging)  
 $= 14 \text{ V.}$
- $P = I^2 r$  (Due to internal resistance)  
 $= 50^2 \times 4 \times 10^{-2} = 100 \text{ W}$
- Rate of charging = E.I.  
 $= 12 \text{ V. } 50 \text{ A} = 600 \text{ W}$

**DPP NO. - 50**

- Initially :-  
 $V_v + V_A = 6 \dots(1)$   
 $V_v$  &  $V_A$  being the potential across voltmeter & ammeter respectively after closing  $S_1$ .

$$\frac{V_v}{2} + 2 V_A = 6 \dots(2)$$

Solving (1) & (2)

$$V_v = 4, V_A = 2.$$

after closing  $S_2$  :-

$$V_v = 0$$

$$V_A = 6$$

So that value after closing  $S_2$  is 3/2 times the value after closing  $S_1$ .

- [ Ans:  $V_1 = \frac{10V}{3}, V_2 = \frac{5V}{3}, ]$

- The speed of sound in air is  $v = \sqrt{\frac{\gamma RT}{M}}$   
 $\frac{\gamma}{M}$  of  $H_2$  is least, hence speed of sound in  $H_2$  shall be maximum.

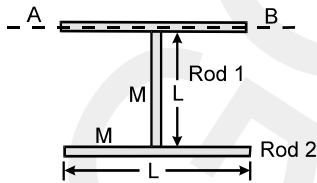

4.

Decrease in PE = Gain in rotational K.E.

$$Mg \frac{L}{2} + MgL = I_{R_3} = I_{R_1} + I_{R_2}$$

$$\frac{1}{2} \cdot \frac{4}{3} ML^2 \cdot \omega^2 = \frac{ML^2}{3} ML^2$$

$$\Rightarrow \frac{3}{2} MgL = \frac{2}{3} ML^2 \cdot \omega^2 = \frac{4ML^2}{3}$$

$$\Rightarrow \frac{9g}{4L} = \omega^2 \Rightarrow \omega = \sqrt{\frac{9g}{4L}}$$

$$[ \text{Ans.: } \omega = \sqrt{\frac{9g}{4L}} ]$$

- From given data

$$\vec{V}_M = 5\sqrt{2} \hat{i} + 5\sqrt{2} \hat{j}$$

velocity of man

Velocity of wind

$$\vec{V}_W = 5\sqrt{2} \hat{i}$$

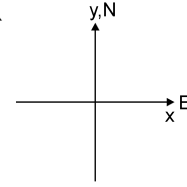

The flag will flutter in the direction in which wind is blowing with respect to the man holding the flag.

$$\Rightarrow \vec{V}_{WM} = \vec{V}_W - \vec{V}_M$$

$$\vec{V}_{WM} = (5\sqrt{2} \hat{i}) - (5\sqrt{2} \hat{i} + 5\sqrt{2} \hat{j})$$

$$\vec{V}_{WM} = -5\sqrt{2} \hat{j} = 5\sqrt{2} (-\hat{j})$$

This implies direction of wind with respect to man in south.

**Flag will flutter in south direction. Ans.**

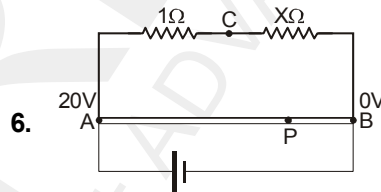

6.

Let reference potential of B be zero. No current shall flow through galvanometer.

If  $V_C - V_P = 16$  volts.

Now  $V_P = 2$  volts.

$\therefore V_C$  should be 18 volts.

$$\text{Now } \frac{V_A - V_C}{1} = \frac{V_C - V_B}{X}$$

Solving  $X = 9 \Omega$ .

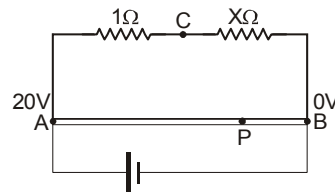

- Balance point is independent of r. It can be seen for balance point at P,  $V_C - V_P = E$  in absence of cell, jockey and galvanometer.

- For balance point at P.

$$V_C - V_P = E = 12$$

$\therefore V_C = 18$ ,  $V_P$  should be 6 volts.

Therefore

$$\frac{V_A - V_P}{l} = \frac{V_P - 0}{100 - l} \text{ or } l = 70 \text{ cm.}$$

**DPP NO. - 51**

1.  $E - ir_1 = 0 \Rightarrow i = \frac{E}{r_1}$  and  $i = \frac{2E}{r_1 + r_2 + R}$

Therefore  $R = r_1 - r_2$   
 $= 2 \Omega$

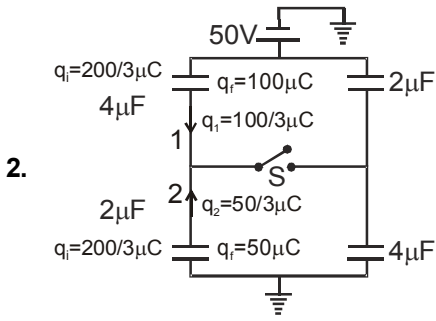

Initial and final charges are marked on  $4\mu\text{f}$  and  $2\mu\text{f}$  capacitors as shown.  
 Hence charge passing through segment 1 and 2 are

$q_1 = \frac{100}{3} \mu\text{C}$        $q_2 = \frac{50}{3} \mu\text{C}$

$\therefore$  charge through switch =  $q_1 + q_2 = 50 \mu\text{C}$ .

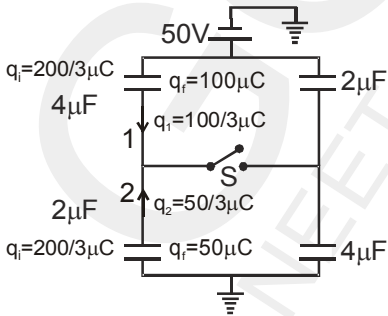

3. The equation of pressure variation due to sound is

$p = -B \frac{ds}{dx} = -B \frac{d}{dx} [s_0 \sin^2(\omega t - kx)]$

$= B ks_0 \sin(2\omega t - 2kx)$

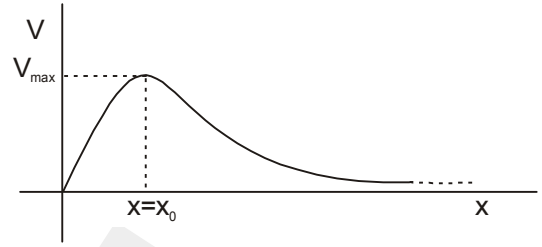

$x = x_0$  is the point where potential is maximum. So, if the impulse is sufficient enough and point charge crosses the maximum PE barrier than point charge will move to infinity otherwise it will perform oscillatory motion and for very small impulse the motion may be SHM.

**Sol.(69-72)**

Resistance of wire AB is -

$R_{AB} = \left( \frac{\rho_0 \ell}{2} \right) \frac{\ell}{A} = \frac{24\pi}{2\pi} = 12\Omega$        $\left\{ R = \int_0^{\ell} \frac{\rho dx}{A} \right\}$

Current in wire AB is  $I = \frac{15}{12+3} = 1\text{A}$

when switch is open, null point at C ( $AC = x$ )

$R_{AC} = \left( \frac{\rho_0 x}{2} \right) \left( \frac{x}{A} \right) = \frac{\rho_0 x^2}{2A} = \frac{24\pi \frac{2}{3}}{2\pi} = 8\Omega$

EMF  $E = 1 \times 8 = 8\text{V}$

when switch closed null point at D ( $AD = x$ )

$R_{AD} = \left( \frac{\rho_0 x}{2} \right) \left( \frac{x}{A} \right) = \frac{\rho_0 x^2}{2A} = \frac{24\pi \frac{1}{2}}{2\pi} = 6\Omega$

$\Delta V_{\text{battery}} = 6 \times 1$

$\Delta V_{\text{बैटरी}} = 6 \times 1$

$8 - \frac{8}{r+3} r = 6$

$r = 1 \Omega$

**DPP NO. - 52**

2. (C) For pipe A, second resonant frequency is third

harmonic thus  $f = \frac{3V}{4L_A}$

For pipe B, second resonant frequency is second

harmonic thus  $f = \frac{2V}{2L_B}$

Equating,  $\frac{3V}{4L_A} = \frac{2V}{2L_B}$

$\Rightarrow L_B = \frac{4}{3} L_A = \frac{4}{3} \cdot (1.5) = 2\text{m}$ .

5. [Ans:  $V_{AB} = \frac{\epsilon}{(1+3\eta+\eta^2)} = 10V$ ]

The distribution of charges is shown in fig. In closed loop (1)

$$\epsilon - \frac{q}{C_1} - \frac{(q-q_1)}{C_2} = 0 \quad \dots(i)$$

In closed loop (2)  $-\frac{q_1}{C_1} - \frac{q_1}{C_2} + \frac{q-q_1}{C_2} = 0$

or  $q = \left(\frac{2C_1+C_2}{C_1}\right) q_1$

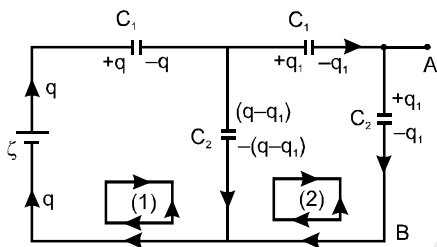

From Eq. (i),  $\epsilon - \frac{q_1}{C_1} - \frac{q}{C_2} + \frac{q_1}{C_2} = 0$

or  $\epsilon + \frac{q_1}{C_2} = q \left(\frac{C_1+C_2}{C_1C_2}\right)$

or  $\epsilon + \frac{q_1}{C_2} = \left(\frac{2C_1+C_2}{C_1}\right) q_1 \left(\frac{C_1+C_2}{C_1C_2}\right)$

$$\therefore q_1 = \frac{\epsilon C_2 C_1^2}{C_1^2 + 3C_1 C_2 + C_2^2}$$

$$\therefore \phi_A - \phi_B = \left|\frac{-q_1}{C_2}\right| = \frac{q_1}{C_2}$$

$$= \frac{\epsilon C_1^2}{C_1^2 + 3C_1 C_2 + C_2^2}$$

$$= \frac{\epsilon}{1+3\frac{C_2}{C_1} + \frac{C_2^2}{C_1^2}}$$

$$= \frac{\epsilon}{1+3\eta+\eta^2} = 10V$$

$$\left(\because \frac{C_2}{C_1} = \eta = 2\right)$$

6. Torque equation

$$\tau_{\text{Hinge}} = I_{\text{Hinge}} \omega$$

$$mg \ell = \left(\frac{m(4\ell)^2}{12} + m\ell^2\right) \omega$$

$$\frac{3g}{7\ell} = \omega$$

Tangential acceleration =  $\omega \ell = \frac{3g}{7}$

Radial acceleration =  $\omega^2 \ell = 0$

Ans.  $\frac{3g}{7}$

7.  $mg - N_1 = m \left(\frac{3g}{7}\right)$

$$N_1 = \frac{4mg}{7}$$

$$N_2 = 0$$

8. Energy conservation

$$mg \ell = \frac{1}{2} \cdot \frac{7}{3} m \ell^2 \omega^2$$

$$\sqrt{\frac{6g}{7\ell}} = \omega$$

**DPP NO. - 53**

1. Moment of inertia of semicircular portions about x and y axes are same. But moment of inertia of straight portions about x-axis is zero.

$$\therefore I_x < I_y \quad \text{or} \quad \frac{I_x}{I_y} < 1$$

2. As voltage applied across capacitor is same i.e. 10V in both case. Therefore in both case

$Ed = 10 \Rightarrow E = \frac{10}{d}$ , as d is constant. Therefore electric field remains the same as 10 V/m

3. after collision

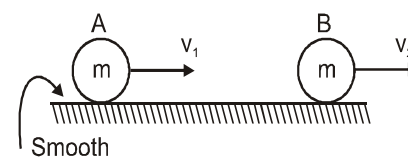

By momentum conservation in horizontal direction

$$V = V_1 + V_2 \quad \dots\dots\dots(i)$$

and

$$e = \frac{V_2 - V_1}{V} = \frac{1}{2} \quad \dots\dots\dots(ii)$$

By (i) and (ii)  $V_2 = \frac{3V}{4}$

So impulse on B

$$= m \left( \frac{3V}{4} \right)$$

and loss in K.E.

$$= \frac{3}{16} mV^2$$

**Ans.** 3000

Time period is minimum for the satellites with minimum radius of the orbit i.e. equal to the radius of the planet. Therefore.

$$\frac{GMm}{R^2} = \frac{mv^2}{R}$$

$$\Rightarrow V = \sqrt{\frac{GM}{R}}$$

$$T_{\min} = \frac{2\pi R}{\sqrt{\frac{GM}{R}}}$$

$$= \frac{2\pi R\sqrt{R}}{\sqrt{GM}}$$

using  $M = \frac{4}{3} \rho R^3$

$$T_{\min} = \sqrt{\frac{3\pi}{G\rho}}$$

Using values  $T_{\min} = 3000$  s

When  $S_1$  is closed

$$i = \frac{\epsilon_p}{2r+r} = \frac{\epsilon_p}{3r}$$

$$\therefore \epsilon = \frac{\epsilon_p}{3r} \cdot r = \frac{\epsilon_p}{3} \quad \dots\dots\dots(1)$$

when  $S_2$  is closed (Let resistance of  $w_2$  be R)

$$i = \frac{\epsilon_p}{R+r}$$

$$\epsilon = \frac{\epsilon_p}{R+r} \cdot \left( R \cdot \frac{2}{3} \right) \quad \dots\dots\dots(2)$$

**From (1) & (2)  $R = r$ . Ans.**

**Alternate Solution :**

If in second case both  $S_1$  &  $S_2$  are closed,

$$\epsilon = \frac{\epsilon_p}{r+2r} \cdot \frac{2r}{l} \cdot \frac{l}{2} = \frac{\epsilon_p}{3}$$

$$\epsilon = \frac{\epsilon_p}{r + \frac{2rx}{2r+x}} \cdot \frac{2rx}{2r+x} \cdot \frac{2}{3}$$

$$\Rightarrow \frac{\epsilon_p}{3} = \frac{4\epsilon_p x}{2r+x+2x}$$

**Sol.(57 to 59)**

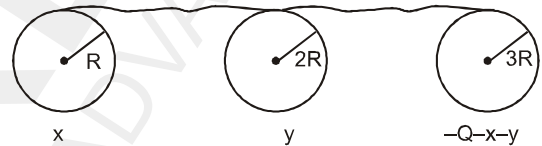

Final potential of spheres will be same

$$\text{So, } K \frac{x}{R} = \frac{Ky}{2R} = \frac{K(-Q-x-y)}{3R}$$

$$y = 2x \quad \text{and} \quad 3x = -Q - x - y$$

$$\therefore 6x = -Q$$

$$x = -\frac{Q}{6} \quad y = -\frac{Q}{3}$$

Charge on sphere of radius 3R is  $-\frac{Q}{2}$

Change in potential energy of sphere of radius 'R' is

$$\Delta U = \frac{KQ^2}{2R} - \frac{K(-Q/6)^2}{2R}$$

$$\Delta U = \frac{35KQ^2}{72R}$$

**DPP NO. - 54**

**1.** At highest point

$$mu = \frac{2m}{3} v - 2u \frac{m}{3}$$

$$mu + \frac{2u}{3} = \frac{2}{3} v$$

$$\Rightarrow v = \frac{5u}{2}$$

$$\text{total horizontal distance} = \frac{5R}{2 \cdot 2} + \frac{R}{2} = \frac{7R}{4}$$

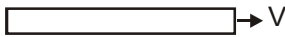

2. (i)

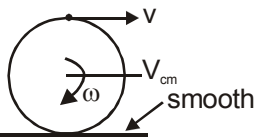

$$V_{cm} + \omega R = V$$

$$V_{cm} = V - \omega R$$

$\omega$  depends on value of friction between plank & cylinder, hence  $V_{cm}$  is undetermined.

(ii)  $\omega = \frac{2v}{2R} = \frac{V}{R}$       (iii)  $\omega = \frac{2V}{2R} = \frac{V}{R}$   
 $V_{cm} = 0$

(iv)  $\omega_{AC} = \frac{3V - V}{R} = \frac{2V}{R} \Rightarrow \omega = \frac{2V}{R}$

8.  $E_x = -\frac{\partial V}{\partial x} = -\frac{4}{1}$

$E_z = -\frac{4-8}{1/\sqrt{3}} = 4\sqrt{3}$

$|\vec{E}| = \sqrt{E_x^2 + E_z^2} = \sqrt{64} = 8 \text{ N/kg}$       Ans. (A)

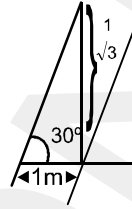

**DPP NO. - 55**

3.  $\therefore$  wheat stone bridge is in balanced condition

So  $\frac{100}{l_1} = \frac{100+x}{l_2}$

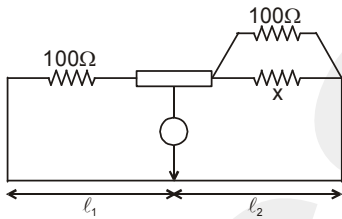

$\therefore \frac{l_1}{l_2} = 2$

$\Rightarrow x = 100 \Omega$

5. As gravitational force provides centripetal force

$\frac{mv^2}{r} = \frac{GMm}{r^3}$

i.e.,  $v^2 = \frac{GM}{r^2}$

So that  $T = \frac{2\pi r}{v} = 2\pi r \sqrt{\frac{r^2}{GM}}$

$\therefore T^2 \propto r^4$

Ans. 4

6.  $V_A + \frac{1}{2} \times 1 \times (2)^2 = -3$

$V_A = -5$       Ans. (C)

7.  $-\frac{GM}{R}$       Ans. (C)

1.  $E_i = \frac{KQ^2}{2a} + \frac{KQ^2}{4a} + \frac{KQ}{2a} \cdot Q$

$= \frac{KQ^2}{a} + \frac{KQ^2}{4a} = \frac{5KQ^2}{4a}$

$E_f = \frac{K(2Q)^2}{4a} = \frac{KQ^2}{a}$

$E_i - E_f = H = \frac{KQ^2}{4a}$

2. In potentiometer wire potential difference is directly proportional to length

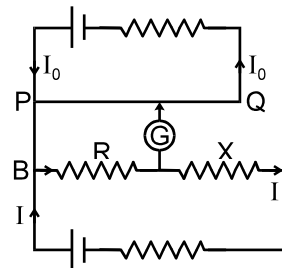

Let potential drop unit length a potentiometer wire be K.

For zero deflection the current will flow independently in two circles

$IR = K \times 10$       .... (1)

$IR + IX = K \times 30$       .... (2)

(2) - (1)

$\Rightarrow IX = k \times 20$       .... (3)

(1)/(2) =  $\frac{R}{X} = \frac{1}{2}$

3. Let  $\sigma$  be the charge density of conducting plate and  $V$  be the volume of either dielectric

$$\therefore \frac{U_1}{U_2} = \frac{\left(\frac{1}{2} k_1 \epsilon_0 E_1^2\right) V}{\left(\frac{1}{2} k_2 \epsilon_0 E_2^2\right) V}$$

$$= \frac{k_1 \left(\frac{\sigma}{k_1 \epsilon_0}\right)^2}{k_2 \left(\frac{\sigma}{k_2 \epsilon_0}\right)^2} = \frac{k_2}{k_1}$$

4. 2

PE = -4 MJ

TE = -2MJ

The additional energy required to make the satellite escape = +2MJ.

5. Applying conservation of mech. energy.

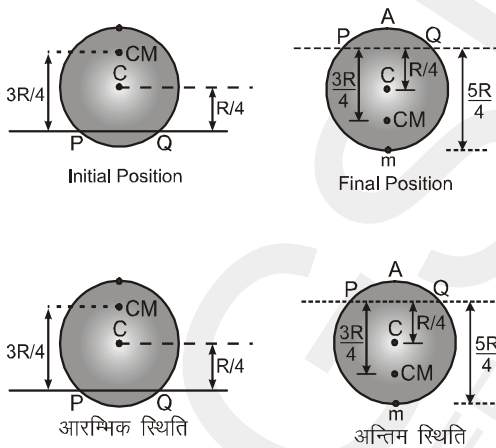

decrease in P.E. = increase in rotational K.E.

$$\Rightarrow (2m) g 2\left(\frac{3R}{4}\right) = \frac{1}{2} [I_{\text{system}}] \omega^2$$

$$3 mgR = \frac{1}{2} [I_{\text{disc.}} + I_{\text{mass}}] \omega^2$$

$$3 mgR$$

$$= \frac{1}{2} \left[ \frac{mR^2}{4} + \frac{mR^2}{16} + \frac{25mR^2}{16} \right] \omega^2$$

$$\frac{3g}{R} = \frac{1}{2} \left[ \frac{30}{16} \right] \omega^2 \Rightarrow \sqrt{\frac{16g}{5R}} = \omega$$

$$V_{\text{particle}} = \left(\frac{5}{4}R\right) \omega = \sqrt{5gR}$$

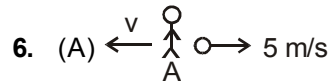

from linear momentum conservation

$$M_A V = m_b 5 \Rightarrow v = \frac{4 \times 5}{40} = 0.5 \text{ m/s Ans.}$$

7. (C)

$$m_A 0.5 + m_b 5 = (M_A + m_b) V_1$$

$$V_1 = \frac{40 \times 0.5 + 4 \times 5}{44} = \frac{40}{44} = \frac{10}{11} \text{ m/s Ans.}$$

8. (C)

after through the ball velocity of man A is 0.5 m/s  
 For man B

$$4 \times 5 = 40 v_2 - 4 \times 5 \Rightarrow v_2 = 1 \text{ m/s}$$

velocity B is 1 m/s after through the ball

after through the ball second time, velocity of man A is

$$4 \times 5 + 40 \times 0.5 = 40 \times v_3 - 4 \times 5$$

$$v_3 = 1.5 \text{ m/s}$$

similarly for man B  $v_4 = 2 \text{ m/s}$

after 5 round trip and man A hold the ball velocity of man B is 5 m/s

velocity of man A

$$4.5 \times 40 + 4 \times 5 = (40 + 4)v_5$$

$$v_5 = \frac{50}{11} \text{ m/s Ans.}$$

9. (A)

When man through the ball 6 times it velocity is greater than 5 m/s and velocity of B is 5 m/s therefore maximum number of times man A can through the ball is 6.

10.  $F_{\text{ext}} = 0$ , Centre of mass of system cannot move  
 Initial position of centre of mass from A.

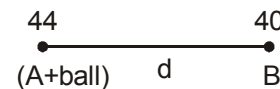

$$X_{\text{cm}} = \frac{40d}{44 + 40} = \frac{10}{21} d$$

### DPP NO. - 56

1. Potential drop.  $\rightarrow V = i (R + R_A)$

$$\frac{V}{i} = R + R_A = R_{\text{measured}}$$

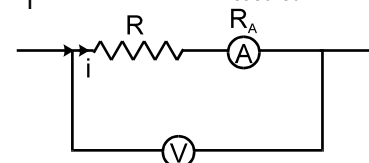

4. When charge on plate is constant electric field

$$\text{remains constant } E = \frac{Q}{2A\epsilon_0}$$

In case when potential difference is constant  $E =$

$$\frac{V}{d}$$

Electric field increases when 'd' decreases and hence chances of breakdown increases.

5.  $C = k \epsilon_0 A / d$

$$A_f = 4A_i$$

$$d_f = 2d_i$$

Because, ALL linear dimensions are doubled so capacitance become doubled.

6.  $x = 3 \sin 100 t + 8 \cos^2 50 t$

$$= 3 \sin 100 t + \frac{8[1 + \cos 100t]}{2}$$

$$x = 4 + 3 \sin 100 t + 4 \cos 100 t$$

$$(x - 4) = 5 \sin (100t + \phi) \quad \left\{ \tan \phi = \frac{4}{3} \right\}$$

Amplitude = 5 units

Maximum displacement = 9 units.

7.  $C = k \epsilon_0 A / d$

formula suggest that it depends on area, separation and surrounding medium.

9. Most Appropriate capacitor is a capacitors of high capacitance & high dielectric strength. By dielectric strength

$$C > B > A > D$$

$$\text{By capacitance } C = \frac{k\epsilon_0 A}{d}$$

$$C = D > B > A$$

So C is best.

3. Switches open :

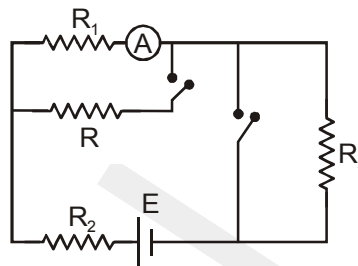

$$I_A = \frac{E}{R_1 + R_2 + R_3}$$

Switches closed :

There will be no current through  $R_3$ .

Current through E and  $R_2$

$$I' = \frac{E}{R_2 + \frac{R R_1}{R + R_1}}$$

Current through the ammeter

$$I'_A = \frac{R I'}{R + R_1} = \frac{R E}{(R + R_1) R_2 + R R_1}$$

$$= \frac{E}{R_1 + R_2 + \frac{R_2 R_1}{R}}$$

As  $I_A = I'_A$

$$R = \frac{R_1 R_2}{R_3} = \frac{100 \times 300}{50} = 600 \Omega$$

4. 4 times

$$A_1 = A_3 = 8 \text{ (area)}$$

$$A_2 = A_4 = 9$$

Position of the particle at any time t is given by

$$X = X_0 + \int_0^t V dt \quad X_0 = \text{Initial position}$$

### DPP NO. - 57

2.  $\frac{\Delta T}{T} \times 100 = \frac{1}{2} \frac{\Delta \ell}{\ell} \times 100$  is not valid as  $\Delta \ell$  is not small.

$$T_1 = 2\pi \sqrt{\frac{\ell}{g}} \quad T_2 = 2\pi \sqrt{\frac{2\ell}{g}} \quad \% \text{ change} = \frac{T_2 - T_1}{T_1} \times 100$$

$$100 = (\sqrt{2} - 1) \times 100 = 41.04.$$

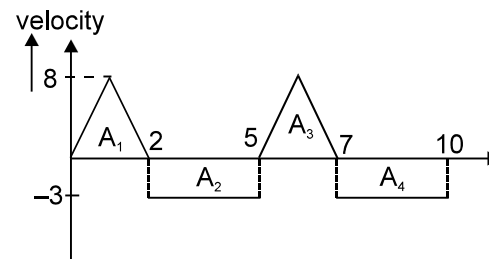

$$\int_0^t V dt = \text{Area under the curve}$$

Now at  $t = 0$   $X = X_0 = -1$   
 at  $t = 2$   $X = X_0 + A_1 = -1 + 8 = 7$   
 at  $t = 5$   $X = X_0 + A_1 - A_2 = -1 + 8 - 9 = -2$   
 $t = 7$   $X = X_0 + A_1 - A_2 + A_3 = -1 + 8 - 9 + 8 = 6$   
 $t = 10$   $X = X_0 + A_1 - A_2 + A_3 - A_4 = -1 + 8 - 9 + 8 - 7 = 3$   
 As during 10 seconds four times the position of the particle changed in sign. Particles passes 4 times the origin

5. Once the switch is closed, the capacitor is charged through resistance  $R_1$  by the battery's e.m.f. Time constant is  $R_1 C$ .

6. Using  $V_c = E(1 - e^{-t/RC})$   
 $\Rightarrow V_c = 12(1 - e^{-2})$   
 $= 10.4 \text{ V}$

7. At any moment in the circuit –

$$V_c + V_{R_1} = 12 \text{ V}$$

$$\Rightarrow V_{R_1} = 12 \text{ V} - 10.4 \text{ V}$$

$$= 1.6 \text{ V}$$

8. If loop law is applied to the left hand loop in clockwise direction

$$E - V_{R_2} = 0$$

$$V_{R_2} = E = 12 \text{ V}$$

i.e.  $V_{R_2}$  does not change during the charging process.

### DPP NO. - 58

1. By symmetry

$$I_{AB} = I_{BC} \text{ \& } I_{AD} = I_{DC}$$

$\therefore$  No current in BO and OD  
 $\therefore T_B = T_O = T_D$

2. In (A)  $x_f - x_i$   
 $0 - x = -x = -ve$   
 So average velocity is  $-ve$ .

3. Speed of block is maximum at mean position. At mean position upper spring is extended and lower spring is compressed.

4.  $\eta$  and  $Y$  are properties of material. These coefficients are independent of geometry of body.
5. Relative to liquid, the velocity of sphere is  $2v_0$  upwards.  
 $\therefore$  viscous force on sphere  
 $= 6\pi\eta r 2v_0$  downward  
 $= 12\pi\eta r v_0$  downward

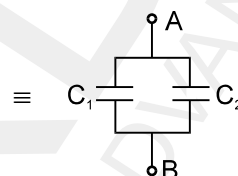
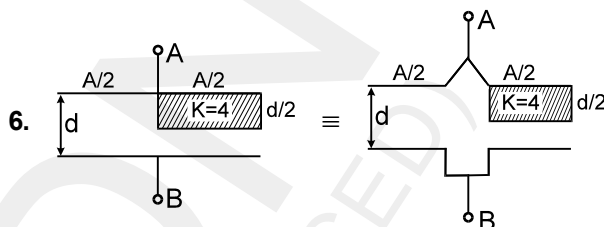

$$C_1 = \frac{\epsilon_0 A/2}{d}, C_2 = \frac{\epsilon_0 A/2}{\frac{d/2}{k} + \frac{d}{2}} = \frac{4\epsilon_0 A}{5d} C$$

$$= C_1 + C_2 = \frac{13}{10} \frac{\epsilon_0 A}{d} \quad \text{Ans.} \quad \frac{13 \epsilon_0 A}{10 d}$$

7. The current through the galvanometer is  $\sim \frac{1}{1000}$  of total current, the  $S \ll G$ .

8. Potential difference across galvanometer = Potential difference across S.

$$\Rightarrow i_g \cdot G = (I - i_g) \cdot S$$

$$\Rightarrow 10 \times 10^{-3} \cdot 10 = (1 - 10 \times 10^{-3}) \cdot S$$

$$\Rightarrow R_s = \frac{10^{-1}}{1 - 10^{-2}} = \frac{10}{99} \Omega$$

### DPP NO. - 59

3. (A) Moment of inertia of the rod w.r.t. the axis through centre of the disc is : (by parallel axis theorem).

$$I = \frac{mL^2}{12} + mR^2$$

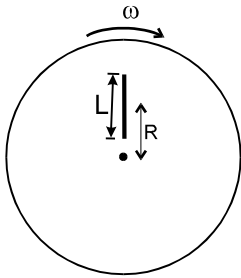

& K.E. of rod w.r.t. disc

$$= \frac{1}{2} I \omega^2$$

$$= \frac{1}{2} m \omega^2 \left[ R^2 + \frac{L^2}{12} \right] \quad \text{Ans.}$$

5. Since, Heat energy radiated per sec =  $Ae\sigma T^4$   
 where, e is emissivity of the surface which depends upon its nature and A is its area.  
 T is its own temperature (independent of surrounding temperature)  
 Hence, (A) and (C) are correct.

8. Let  $V_A = 0$  volts.

∴ Net current entering node C = 0

$$\therefore \frac{0 - V_C}{2} + \frac{-2 - V_C}{6.5} + \frac{1 - V_C}{2} = 0$$

$$\therefore V_C = \frac{1}{6} \text{ volt.} = \text{p.d. across wire AC.}$$

$$\text{Also } \frac{V_C - V_B}{5} = \frac{V_B + 2}{1.5} = \frac{V_C + 2}{6.5} = \frac{1}{3}$$

$$\therefore V_C - V_B = \frac{5}{3} = \text{p.d. across wire BC}$$

$$\therefore V_C > V_B > V_A$$

Hence potential gradient across BC =

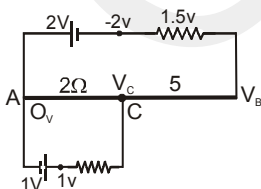

$$\frac{5/3}{1/2} = \frac{10}{3} \text{ V/m}$$

also potential gradient across

$$\text{AC } \frac{1/6}{1/5} = \frac{5}{6} \text{ V/m}$$

## DPP NO. - 60

2. The velocity of the body a time t is given by

$$v = \frac{dx}{dt} = \frac{d}{dt} \left( \frac{t^2}{4} \right) = \frac{t}{2}$$

∴ At  $t = 0$ ,  $v = u = 0$  and  $t = 2$  s,  $v = 1 \text{ ms}^{-1}$ , Now,  
 work done = increase in KE

$$= \frac{1}{2} m v^2 - \frac{1}{2} m u^2 = \frac{1}{2} m v^2 - 0$$

$$= \frac{1}{2} m v^2 = \frac{1}{2} \times 6 \times (1)^2 = 3 \text{ J,}$$

Hence the correct choice is (d).

3. From conservation of energy, the kinetic energy of ball at lowest portion is ( $v_c$  = speed of centre of ball)

$$\frac{1}{2} m v_c^2 + \frac{1}{2} \times \frac{2}{5} m v_c^2 = mgR$$

$$\text{or } \frac{7}{10} m v_c^2 = mgR$$

Since net tangential force on sphere at lowest point is zero, net force on sphere at lowest position is

$$= \frac{m v_c^2}{R} = \frac{10}{7} mg \text{ upwards.}$$

$$6. R_A = \frac{R \cdot R_V}{R + R_V} < R$$

$$7. R_B = R + R_G > R$$

8. % error in case A.

$$\frac{R_A - R}{R} \times 100 = \left( \frac{R_V}{R + R_V} - 1 \right) \times 100$$

$$= \frac{-R}{R + R_V} \times 100 \approx -1\%$$

% error in case B

$$\frac{R_B - R}{R} \times 100 = \frac{R_G}{R} \times 100 \approx 10\%$$

Hence percentage error in circuit B is more than that in A.