



GGSRDN

Educational Services Private Limited

9th, 10th, NEET, JEE(Main/Advanced)

अभ्यास ही सबसे बड़ा गुरु है।

CLASS : XI (PHYSICS)

D P P

DAILY PRACTICE PROBLEM

DPP-21 TO 30

DPP 21 : Relative Motion, Projectile Motion, Newton's Law of Motion

DPP 22 : Newton's Law of Motion, Rectilinear Motion, Projectile Motion

DPP 23 : Newton's Law of Motion, Relative Motion

DPP 24 : Relative Motion, Newton's Law of Motion, Projectile Motion

DPP 25 : Newton's Law of Motion

DPP 26 : Newton's Law of Motion, Relative Motion, Projectile Motion, Rectilinear Motion

DPP 27 : Relative Motion, Newton's Law of Motion

DPP 28 : Relative Motion, Newton's Law of Motion

DPP 29 : Friction, Newton's Law of Motion

DPP 30 : Friction

PHYSICS
DPP
 DAILY PRACTICE PROBLEMS

DPP No. 21

Total Marks : 24
 Max. Time : 24 min.

Topics : Relative Motion, Projectile Motion, Newton's Law of Motion

Type of Questions

Single choice Objective ('-1' negative marking) Q.1 to Q.8

(3 marks, 3 min.)

M.M., Min.

[24, 24]

- Two points P and Q move in same plane such that the relative acceleration of P with respect to Q is zero. They are moving such that the distance between them is decreasing. Pick the correct statement for P and Q to collide
 (A) The line joining P and Q should not rotate.
 (B) The line joining P and Q should rotate with constant angular speed
 (C) The line joining P and Q should rotate with variable angular speed
 (D) All the above statement are correct
- A stone projected at an angle of 60° from the ground level strikes at an angle of 30° on the roof of a building of height 'h'. Then the speed of projection of the stone is :

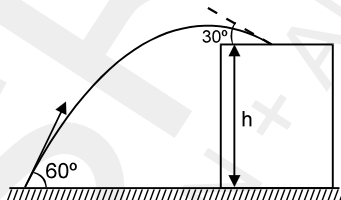

- (A) $\sqrt{2gh}$ (B) $\sqrt{6gh}$ (C) $\sqrt{3gh}$ (D) \sqrt{gh}
- A man is on ship which is moving in east direction with speed 60 km/hr. Waves of ocean is taking ship towards west with speed 20 km/hr. Man start running on ship with flag in his hand in north direction with speed 30 km/hr and wind is blowing with 50 km/hr, 37° towards south of west then find the direction of flutter the flag as seen by man on ground.
 (A) 37° south of west (B) 53° south of west
 (C) 37° west of north (D) flag will not flutter

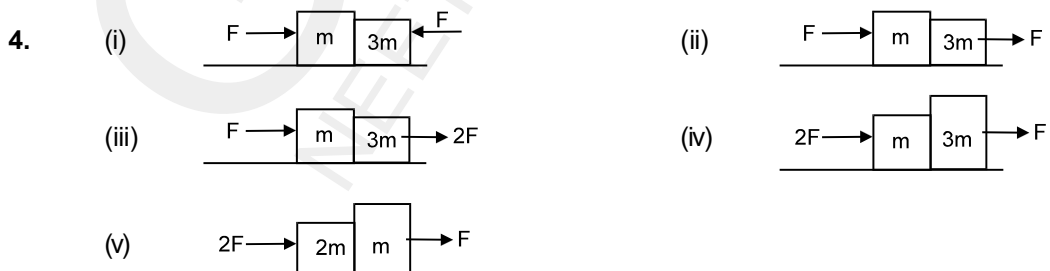

In all the given cases blocks are in contact and the forces are applied as shown. All the surfaces are smooth. Then in which of the following cases, normal reaction between the two blocks is zero :

- (A) (i) , (iv) (B) (ii) , (iii) (C) (iii) (D) (v)

5. A body of mass 1 kg lies on smooth inclined plane. A force $F = 10\text{N}$ is applied horizontally on the block as shown. The magnitude of normal reaction by inclined plane on the block is:

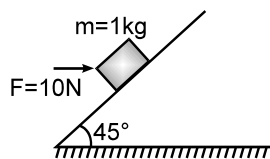

- (A) $10\sqrt{2}$ N (B) $\frac{10}{\sqrt{2}}$ N (C) 10 N (D) none of these
6. A frictionless wire is fixed between A and B inside of a hollow sphere of radius R as shown. A bead slips along the wire starting from the rest at point A. The time taken by the bead to slip from A to B will be

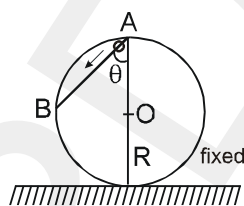

- (A) $2\sqrt{R/g}$ (B) $gR/\sqrt{g\cos\theta}$ (C) $\frac{2\sqrt{gR}}{g\cos\theta}$ (D) $\frac{2\sqrt{gR\cos\theta}}{g}$
7. At $t = 0$, a particle at $(1,0,0)$ moves towards point $(4,4,12)$ with a constant velocity of magnitude 65 m/s. The position of the particle is measured in metres and time in sec. Assuming constant velocity, the position of the particle at $t = 2$ sec is :
- (A) $(13\hat{i} - 120\hat{j} + 40\hat{k})\text{m}$ (B) $(40\hat{i} + 31\hat{j} - 120\hat{k})\text{m}$
 (C) $(13\hat{i} - 40\hat{j} + 12\hat{k})\text{m}$ (D) $(31\hat{i} + 40\hat{j} + 120\hat{k})\text{m}$
8. A constant force acts on a mass m at rest. Velocity acquired in travelling a fixed distance is directly proportional to :
- (A) \sqrt{m} (B) m (C) $\frac{1}{\sqrt{m}}$ (D) none

Topics : Newton's Law of Motion, Rectilinear Motion, Projectile Motion

Type of Questions

Single choice Objective ('-1' negative marking) Q.1 to Q.6

(3 marks, 3 min.)

M.M., Min.

[18, 18]

Multiple choice objective ('-1' negative marking) Q.7 to Q.8

(4 marks, 4 min.)

[8, 8]

1. A uniform sphere of weight w and radius 3 m is being held by a string of length 2 m. attached to a frictionless wall as shown in the figure. The tension in the string will be:

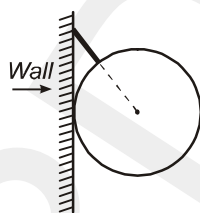

- (A) $5w/4$ (B) $15w/4$ (C) $15w/16$ (D) none of these
2. Two weights W_1 and W_2 in equilibrium and at rest, are suspended as shown in figure. Then the ratio $\frac{W_1}{W_2}$ is:

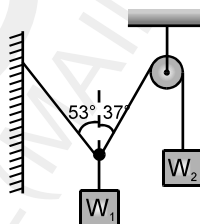

- (A) $5/4$ (B) $4/5$ (C) $8/5$ (D) none of these
3. If $v = x^2 - 5x + 4$, find the acceleration of the particle when velocity of the particle is zero.
- (A) 0 (B) 2 (C) 3 (D) none of these
4. Three weights are hanging over a smooth fixed pulley as shown in the figure. What is the tension in the string connecting weights B and C?

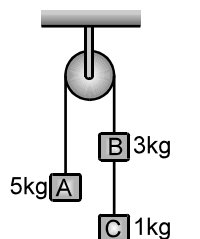

- (A) g (B) $g/9$ (C) $8g/9$ (D) $10g/9$

5. A ball is shot in a long hall having a roof at a height of 10m with 25 m/s at an angle of 37° with the floor. The ball lands on the floor at a distance of from the point of projection. (Assume elastic collisions if any)

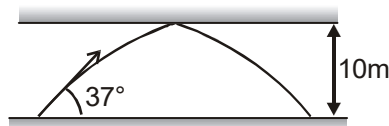

- (A) 40 m (B) 60 m (C) $45/4$ m (D) 20 m

6. Two smooth spheres each of radius 5 cm and weight W is in equilibrium inside a fixed smooth cylinder of radius 8 cm as shown in the figure. The reactions between the spheres and the vertical side of the cylinder are:

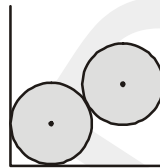

- (A) $W/4$ & $3W/4$ (B) $W/4$ & $W/4$
 (C) $3W/4$ & $3W/4$ (D) W & W

7. A cart of mass 0.5 kg is placed on a smooth surface and is connected by a string to a block of mass 0.2 kg. At the initial moment the cart moves to the left along a horizontal plane at a speed of 7 m/s. (Use $g = 9.8 \text{ m/s}^2$)

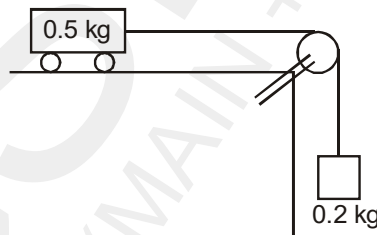

- (A) The acceleration of the cart is $\frac{2g}{7}$ towards right.
 (B) The cart comes to momentary rest after 2.5 s.
 (C) The distance travelled by the cart in the first 5s is 17.5 m.
 (D) The velocity of the cart after 5s will be same as initial velocity.

8. Three blocks are connected by light strings as shown in figure and pulled by a force $F = 60 \text{ N}$. If $m_A = 10 \text{ kg}$, $m_B = 20 \text{ kg}$ and $m_C = 30 \text{ kg}$, then :

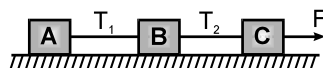

- (A) acceleration of the system is 2 m/s^2 (B) $T_1 = 10 \text{ N}$
 (C) $T_2 = 30 \text{ N}$ (D) $T_1 = 20 \text{ N}$ & $T_2 = 40 \text{ N}$

PHYSICS
DPP
 DAILY PRACTICE PROBLEMS

DPP No. 23

Total Marks : 27
 Max. Time : 29 min.

Topics : Newton's Law of Motion, Relative Motion

Type of Questions

Single choice Objective ('-1' negative marking) Q.1 to Q.5

(3 marks, 3 min.)

M.M., Min.

[15, 15]

Multiple choice objective ('-1' negative marking) Q.6

(4 marks, 4 min.)

[4, 4]

Subjective Questions ('-1' negative marking) Q.7 to Q.8

(4 marks, 5 min.)

[8, 10]

1. A man of mass m stands on a platform of equal mass m and pulls himself by two ropes passing over pulleys as shown. If he pulls each rope with a force equal to half his weight, his upward acceleration would be :

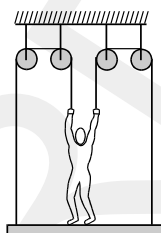

- (A) $g/2$ (B) $g/4$
 (C) g (D) zero

2. Two blocks of masses m_1 and m_2 are connected as shown in the figure. The acceleration of the block m_2 is (pulleys and strings are ideal) :

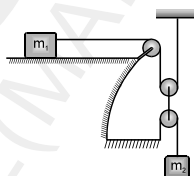

- (A) $\frac{m_2 g}{m_1 + m_2}$ (B) $\frac{m_1 g}{m_1 + m_2}$
 (C) $\frac{4m_2 g - m_1 g}{m_1 + m_2}$ (D) $\frac{m_2 g}{m_1 + 4m_2}$

3. In the system shown in figure assume that cylinder remains in contact with the two wedges. The velocity of cylinder is -

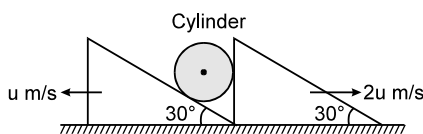

- (A) $\sqrt{19 - 4\sqrt{3}} \frac{u}{2}$ m/s (B) $\frac{\sqrt{13} u}{2}$ m/s
 (C) $\sqrt{3} u$ m/s (D) $\sqrt{7} u$ m/s

4. A system is as shown in the figure. All speeds shown are with respect to ground. Then the speed of Block B with respect to ground is :

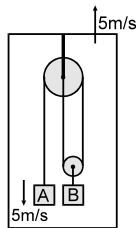

- (A) 5 m/s (B) 10 m/s (C) 15 m/s (D) 7.5 m/s

5. A wedge of height 'h' is released from rest with a light particle P placed on it as shown. The wedge slides down an incline which makes an angle θ with the horizontal. All the surfaces are smooth, P will reach the surface of the incline in time:

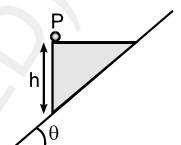

- (A) $\sqrt{\frac{2h}{g \sin^2 \theta}}$ (B) $\sqrt{\frac{2h}{g \sin \theta \cos \theta}}$ (C) $\sqrt{\frac{2h}{g \tan \theta}}$ (D) $\sqrt{\frac{2h}{g \cos^2 \theta}}$

6. A block of weight 9.8N is placed on a table. The table surface exerts an upward force of 10 N on the block. Assume $g = 9.8 \text{ m/s}^2$.

- (A) The block exerts a force of 10N on the table
 (B) The block exerts a force of 19.8N on the table
 (C) The block exerts a force of 9.8N on the table
 (D) The block has an upward acceleration.

7. A block of mass $M_1 = 3 \text{ kg}$ on a smooth fixed inclined plane of angle 30° is connected by a cord over a small frictionless pulley to a second block of mass 2 kg hanging vertically. The tension in the cord and the acceleration of each block are _____ and _____ respectively.

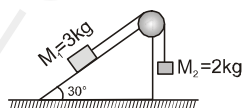

8. In which of the following cases the magnitude of acceleration of the block A will be maximum (Neglect friction, mass of pulley and string)

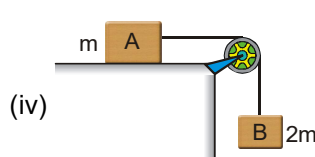
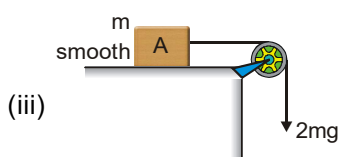
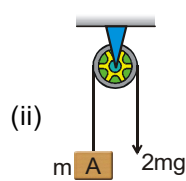
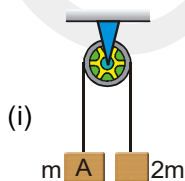

4. A wire is bent in a parabolic shape followed by equation $x = 4y^2$. Consider origin as vertex of parabola. A wire parallel to y axis moves with constant speed 4 m/s along x-axis in the plane of bent wire. Then the acceleration of touching point of straight wire and parabolic wire is (when straight wire has x coordinate = 4 m) :

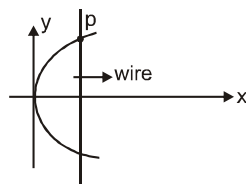

- (A) $\frac{1}{2} \hat{i}$ (B) $-\frac{1}{4} \hat{j}$ (C) $2 \hat{j}$ (D) $4 \hat{i}$
5. Blocks of mass M_1 and M_2 are connected by a cord which passes over the pulleys P_1 and P_2 as shown in the figure. If there is no friction, the acceleration of the block of mass M_2 will be:

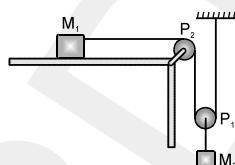

- (A) $\frac{M_2 g}{(4M_1 + M_2)}$ (B) $\frac{2M_2 g}{(4M_1 + M_2)}$ (C) $\frac{2M_1 g}{(M_1 + 4M_2)}$ (D) $\frac{2M_1 g}{(M_1 + M_2)}$

6. In the figure, at the free end of the light string, a force F is applied to keep the suspended mass of 18 kg at rest. Then the force exerted by the ceiling on the system (assume that the string segments are vertical and the pulleys are light and smooth) is: ($g = 10 \text{ m/s}^2$)

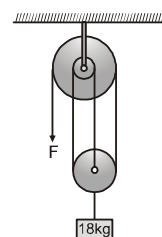

- (A) 60 N (B) 120 N
 (C) 180 N (D) 240 N
 (E) 200 N

7. **True/False**

- (i) Two particles are in projectile motion. The path of one particle as seen by another particle will be a straight line.
 (ii) In order to cross a river of uniform width (flow is also uniform) in shortest time, swimmer must swim in perpendicular direction of river flow.

8. A lift is moving upwards with an acceleration of 2 m/sec^2 . Inside the lift a 4 kg block is kept on the floor. On the top of it, 3 kg block is placed and again a 2 kg block is kept on the 3 kg block. Calculate:

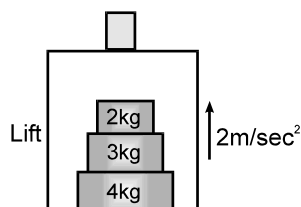

- (i) contact force between 2 kg block and the 3 kg block.
 (ii) contact force between 4 kg block and floor of the lift.
 Draw the free body diagrams properly & take $g = 10 \text{ m/sec}^2$.

Topic : Newton's Law of Motion

Type of Questions

Type of Questions	M.M., Min.
Single choice Objective ('-1' negative marking) Q.1 to Q.4	(3 marks, 3 min.) [12, 12]
Subjective Questions ('-1' negative marking) Q.5	(4 marks, 5 min.) [4, 5]
Comprehension ('-1' negative marking) Q.6 to Q.8	(3 marks, 3 min.) [9, 9]

1. Two blocks 'A' and 'B' each of mass 'm' are placed on a smooth horizontal surface. Two horizontal force F and 2F are applied on the two blocks 'A' and 'B' respectively as shown in figure. The block A does not slide on block B. Then the normal reaction acting between the two blocks is : (A and B are smooth)

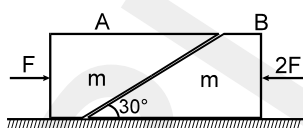

- (A) F
 (B) $F/2$
 (C) $\frac{F}{\sqrt{3}}$
 (D) 3F
2. In the figure shown, a person wants to raise a block lying on the ground to a height h. In both the cases if time required is same then in which case he has to exert more force. Assume pulleys and strings light.

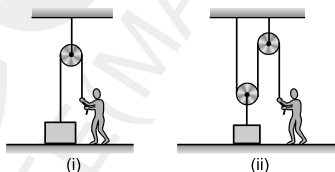

- (A) (i)
 (B) (ii)
 (C) same in both
 (D) Cannot be determined
3. In the pulley system shown in figure, block C is going up at 2 m/s and block B is going up at 4 m/s, then the velocity of block A on the string shown in figure, is equal to :

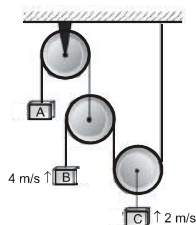

- (A) 2 m/s ↓
 (B) 4 m/s ↓
 (C) 6 m/s ↓
 (D) 8 m/s ↓

4. Two blocks A and B of masses m & $2m$ respectively are held at rest such that the spring is in natural length. Find out the accelerations of blocks A and B respectively just after release (pulley, string and spring are massless).

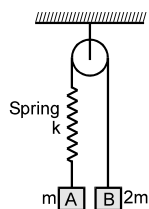

- (A) $g \downarrow, g \downarrow$ (B) $\frac{g}{3} \downarrow, \frac{g}{3} \uparrow$
 (C) $0, 0$ (D) $g \downarrow, 0$
5. Two cubes of masses m_1 and m_2 lie on two frictionless slopes of block A which rests on two frictionless slopes of block A which rests on a horizontal table. The cubes are connected by a string which passes over a pulley as shown in figure. To what horizontal acceleration f the whole system, (i.e. block and cubes) be subjected, so that the cubes do not slide down the planes? What is the tension in the string in this situation?

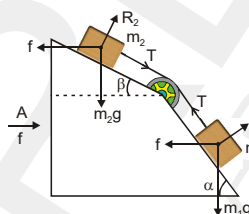

COMPREHENSION

For the following system shown assume that pulley is frictionless, string is massless (m remains on M) :

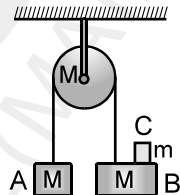

6. The acceleration of the block A is :
 (A) $\frac{mg}{2M+m}$ (B) $\frac{2mg}{2M+m}$ (C) $\frac{mg}{M+2m}$ (D) $\frac{Mg}{M+2m}$
7. Normal reaction on m is (force on C due to B).
 (A) $\frac{Mmg}{2M+m}$ (B) $\frac{2Mmg}{2M+m}$ (C) $\frac{Mmg}{M+2m}$ (D) $\frac{2Mmg}{M+m}$
8. The force on the ceiling is
 (A) $\frac{(M+m) mg}{2M+m}$ (B) $\frac{(6M+5m) mg}{M+m}$ (C) $\frac{(M+m) mg}{M+m}$ (D) $\frac{(6M+5m) Mg}{2M+m}$

PHYSICS
DPP
 DAILY PRACTICE PROBLEMS

DPP No. 26

Total Marks : 27
 Max. Time : 29 min.

Topics : Newton's Law of Motion, Relative Motion, Projectile Motion, Rectilinear Motion

Type of Questions

Type of Questions	M.M., Min.
Single choice Objective ('-1' negative marking) Q.1 to Q.5	(3 marks, 3 min.) [15, 15]
Multiple choice objective ('-1' negative marking) Q.6	(4 marks, 4 min.) [4, 4]
Subjective Questions ('-1' negative marking) Q.7 to Q.8	(4 marks, 5 min.) [8, 10]

- Two men of masses m and $m/2$ starts climbing up on two massless strings fixed at the ceiling with acceleration g and $g/2$ respectively. The ratio of tensions in the two strings will be :
 (A) 2 : 1 (B) 4 : 1
 (C) 4 : 3 (D) 8 : 3
- Two particles at a distance $5m$ apart, are thrown towards each other on an inclined smooth plane with equal speeds ' v '. It is known that both particle move along the same straight line. Find the value of v if they collide at the point from where the lower particle is thrown. Inclined plane is inclined at an angle of 30° with the horizontal. [take $g = 10m/s^2$]
 (A) 2.5 m/sec (B) 5 m/sec
 (C) 7.5 m/sec (D) 10 m/sec
- A particle is projected from a point $(0, 1)$ on Y-axis (assume + Y direction vertically upwards) aiming towards a point $(4, 9)$. It fell on ground along x axis in 1 sec. Taking $g = 10 m/s^2$ and all coordinate in metres. Find the X-coordinate where it fell.
 (A) (3, 0) (B) (4, 0) (C) (2, 0) (D) $(2\sqrt{5}, 0)$
- System shown in figure is in equilibrium. The magnitude of change in tension in the string just before and just after, when one of the spring is cut. Mass of both the blocks is same and equal to m and spring constant of both springs is k . (Neglect any effect of rotation)

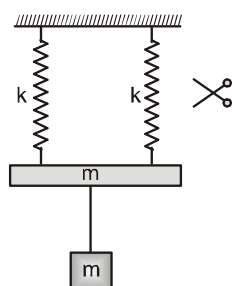

- | | |
|---------------------|---------------------|
| (A) $\frac{mg}{2}$ | (B) $\frac{mg}{4}$ |
| (C) $\frac{3mg}{4}$ | (D) $\frac{3mg}{2}$ |

5. A cylinder rests in a supporting carriage as shown. The side AB of carriage makes an angle 30° with the horizontal and side BC is vertical. The carriage lies on a fixed horizontal surface and is being pulled towards left with an horizontal acceleration 'a'. The magnitude of normal reactions exerted by sides AB and BC of carriage on the cylinder be N_{AB} and N_{BC} respectively. Neglect friction everywhere. Then as the magnitude of acceleration 'a' of the carriage is increased, pick up the correct statement:

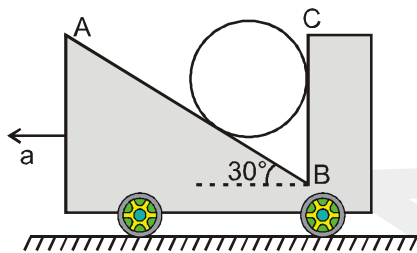

- (A) N_{AB} increases and N_{BC} decreases. (B) Both N_{AB} and N_{BC} increase.
 (C) N_{AB} remains constant and N_{BC} increases. (D) N_{AB} increases and N_{BC} remains constant.

6. A particle is moving in a straight line as :

$$a = 1 \text{ m/s}^2 \quad 0 \leq t \leq 10$$

$$a = 2t \quad t > 10$$

where t is the time and a is the acceleration. If initial velocity of the particle is zero then :

- (A) velocity of the particle at t = 20 sec is 310 m/s
 (B) displacement of the particle in t = 20 s is 1483.33 m.
 (C) acceleration the particle at t = 15 s is 32 m/s².
 (D) v-t graph is

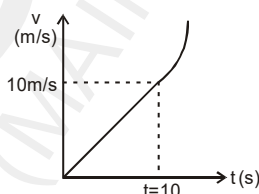

7. A force F is applied on block A of mass M so that the tension in light string also becomes F when block B of mass m acquires an equilibrium state with respect to block A. Find the force F. Give your answer in terms of m, M and g.

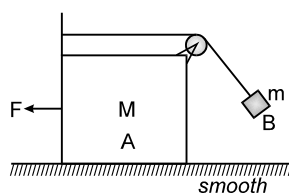

8. During a rainy day, rain is falling vertically with a velocity 2m/s . A boy at rest starts his motion with a constant acceleration of 2m/s^2 along a straight road. Find the rate at which the angle of the axis of umbrella with vertical should be changed so that the rain always falls parallel to the axis of the umbrella.

Topics : Relative Motion, Newton's Law of Motion

Type of Questions

Type of Questions	M.M., Min.
Single choice Objective ('-1' negative marking) Q.1	[3, 3]
Multiple choice objective ('-1' negative marking) Q.2	[4, 4]
Subjective Questions ('-1' negative marking) Q.3	[4, 5]
Comprehension ('-1' negative marking) Q.4 to Q.6	[3, 3]

1. A stone is projected horizontally with speed v from a height h above ground. A horizontal wind is blowing in direction opposite to velocity of projection and gives the stone a constant horizontal acceleration f (in direction opposite to initial velocity). As a result the stone falls on ground at a point vertically below the point of projection. Then the value of height h in terms of f, g, v is (g is acceleration due to gravity)

(A) $\frac{gv^2}{2f^2}$ (B) $\frac{gv^2}{f^2}$ (C) $\frac{\sqrt{2}gv^2}{f^2}$ (D) $\frac{2gv^2}{f^2}$

2. Two blocks of masses $m_1 = 2\text{kg}$ and $m_2 = 5\text{kg}$ hang over a massless pulley as shown in the figure. A force $F_0 = 100\text{N}$ acting at the axis of the pulley accelerates the system upwards. Then : (Take $g = 9.8\text{ m/s}^2$)

- (A) Acceleration of 2 kg mass is 15.2 m/sec^2
 (B) Acceleration of 5kg mass is 0.2 m/sec^2
 (C) Acceleration of both the masses is same
 (D) Acceleration of both the masses is upward

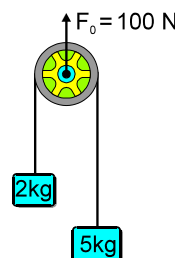

3. A 1 kg block 'B' rests as shown on a bracket 'A' of same mass. Constant forces $F_1 = 20\text{ N}$ and $F_2 = 8\text{ N}$ start to act at time $t = 0$ when the distance of block B from pulley is 50 cm . Time when block B reaches the pulley is _____. (Assume that friction is absent everywhere. Pulley and string are light.)

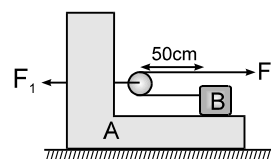

COMPREHENSION

Two smooth blocks are placed at a smooth corner as shown. Both the blocks are having mass m . We apply a force F on the small block m . Block A presses the block B in the normal direction, due to which pressing force on vertical wall will increase, and pressing force on the horizontal wall decrease, as we increase F . ($\theta = 37^\circ$ with horizontal). As soon as the pressing force on the horizontal wall by block B becomes zero, it will loose the contact with the ground. If the value of F is further increased, the block B will accelerate in upward direction and simultaneously the block A will move toward right.

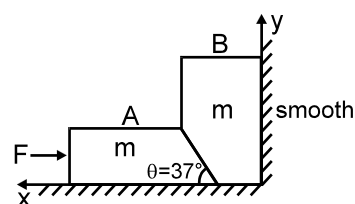

4. What is minimum value of F , to lift block B from ground :

(A) $\frac{25}{12} mg$ (B) $\frac{5}{4} mg$ (C) $\frac{3}{4} mg$ (D) $\frac{4}{3} mg$

5. If both the blocks are stationary, the force exerted by ground on block A is :

(A) $mg + \frac{3F}{4}$ (B) $mg - \frac{3F}{4}$ (C) $mg + \frac{4F}{3}$ (D) $mg - \frac{4F}{3}$

6. If acceleration of block A is a rightward, then acceleration of block B will be :

(A) $\frac{3a}{4}$ upwards (B) $\frac{4a}{3}$ upwards (C) $\frac{3a}{5}$ upwards (D) $\frac{4a}{5}$ upwards

PHYSICS
DPP
 DAILY PRACTICE PROBLEMS

DPP No. 28

Total Marks : 24
 Max. Time : 25 min.

Topics : Relative Motion, Newton's Law of Motion

Type of Questions

Type of Questions	M.M., Min.
Single choice Objective ('-1' negative marking) Q.1 to Q.4	(3 marks, 3 min.) [12, 12]
Multiple choice objective ('-1' negative marking) Q.5 to Q.6	(4 marks, 4 min.) [8, 8]
Subjective Questions ('-1' negative marking) Q.7	(4 marks, 5 min.) [4, 5]

1. Two stones A and B are projected from an inclined plane such that A has range up the incline and B has range down the incline. For range of both stones on the incline to be equal in magnitude, pick up the correct condition. (Neglect air friction)

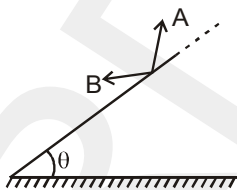

- (A) Component of initial velocity of both stones along the incline should be equal and also component of initial velocity of both stones perpendicular to the incline should be equal.
 (B) Horizontal component of initial velocity of both stones should be equal and also vertical component of initial velocity of both stones should be equal.
 (C) Component of initial velocity of both stones perpendicular to the incline should be equal and also horizontal component of initial velocity of both stones should be equal in magnitude.
 (D) None of these.
2. A man is moving downward on an inclined plane ($\theta = 37^\circ$) with velocity v_0 and rain drops appear to him moving in horizontal direction with velocity $2v_0$ towards him. If man increases his velocity to $2v_0$ his velocity of rain drops as observed by man is :

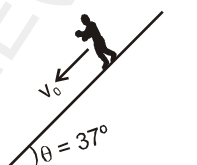

- (A) $\sqrt{\frac{41}{5}} v_0$ (B) $\sqrt{39} v_0$
 (C) $7 v_0$ (D) $6 v_0$
3. System is shown in the figure. Velocity of sphere A is 9 m/s. Then speed of sphere B will be:

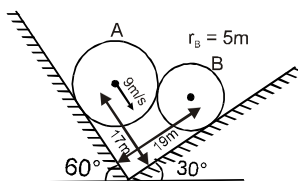

- (A) 9 m/s (B) 12 m/s
 (C) $9 \times \frac{5}{4}$ m/s (D) none of these

4. Objects A and B each of mass m are connected by light inextensible cord. They are constrained to move on a frictionless ring in a vertical plane as shown in figure. The objects are released from rest at the positions shown. The tension in the cord just after release will be

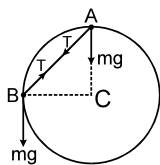

- (A) $mg\sqrt{2}$ (B) $\frac{mg}{\sqrt{2}}$ (C) $\frac{mg}{2}$ (D) $\frac{mg}{4}$

5. In the figure shown all the surface are smooth. All the blocks A, B and C are movable X-axis is horizontal and y-axis vertical as shown. Just after the system is released from the position as shown.

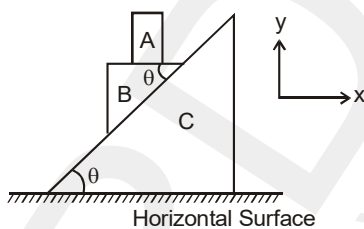

- (A) Acceleration of 'A' relative to ground is in negative y-direction
 (B) Acceleration of 'A' relative to B is in positive x-direction
 (C) The horizontal acceleration of 'B' relative to ground is in negative x-direction.
 (D) The acceleration of 'B' relative to ground directed along the inclined surface of 'C' is greater than $g \sin \theta$.

6. A block B of mass 0.6 kg slides down the smooth face PR of a wedge A of mass 1.7 kg which can move freely on a smooth horizontal surface. The inclination of the face PR to the horizontal is 45° . Then :

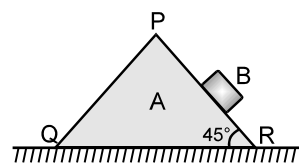

- (A) the acceleration of A is $3g/20$
 (B) the vertical component of the acceleration of B is $23g/40$
 (C) the horizontal component of the acceleration of B is $17g/40$
 (D) none of these

7. Find the tension in the string and the extension in the spring at equilibrium. Where pulley, strings and springs are ideal.

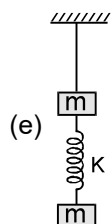
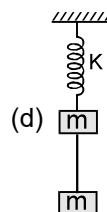
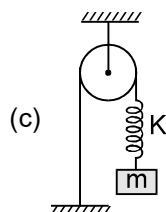
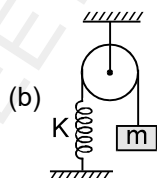
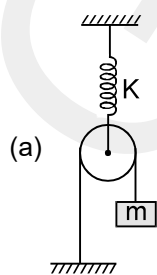

PHYSICS
DPP
 DAILY PRACTICE PROBLEMS

DPP No. 29

Total Marks : 26
 Max. Time : 28 min.

Topics : Friction, Newton's Law of Motion

Type of Questions

Type of Questions	M.M., Min.
Single choice Objective ('-1' negative marking) Q.1 to Q.3	(3 marks, 3 min.) [9, 9]
Subjective Questions ('-1' negative marking) Q.4 to Q.5	(4 marks, 5 min.) [8, 10]
Comprehension ('-1' negative marking) Q.6 to Q.8	(3 marks, 3 min.) [9, 9]

1. A particle of mass 5 kg is moving on rough fixed inclined plane with constant velocity of 5 m/s as shown in the figure. Find the friction force acting on a body by plane.

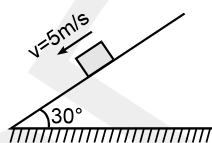

- (A) 25 N (B) 20 N
 (C) 30 N (D) none of these
2. A block of mass 4 kg is kept on ground. The co-efficient of friction between the block and the ground is 0.80. An external force of magnitude 30 N is applied parallel to the ground. The resultant force exerted by the ground on the block is:
 (A) 40 N (B) 30 N (C) 0 N (D) 50 N
3. If the coefficient of friction between A and B is μ , the maximum horizontal acceleration of the wedge is a for which B will remain at rest w.r.t the wedge is :

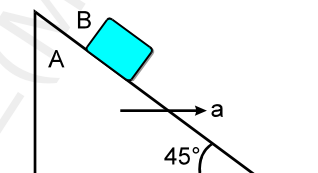

- (A) μg (B) $g \left(\frac{1+\mu}{1-\mu} \right)$
 (C) $\frac{g}{\mu}$ (D) $g \left(\frac{1-\mu}{1+\mu} \right)$
4. In the figure shown, a person pulls a light string with a constant speed $u = 10 \text{ m/s}$. The other end of the string is tied to a very small block which moves on a smooth horizontal surface. Find the angle ' θ ' when the block leaves the surface. Take $g = 10 \text{ m/s}^2$.

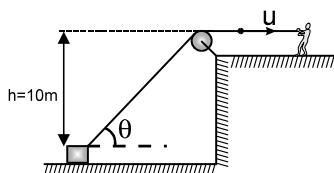

5. Answer the following briefly. (Answer should not be of more than one or two line)
- Can friction coefficient be greater than unity?
 - Why is friction force Nonconservative force?
 - Can friction do positive work?
 - Is earth an inertial frame?
 - Greater force is required to make the body move than to keep it moving, hence we can say that static friction is always greater than kinetic friction. Comment on it.
 - Lesser force is required to pull a lawn mower than to push it. Why?

COMPREHENSION

A meter stick AB of length 1 meter rests on a frictionless floor in horizontal position with end A attached to the string as shown. Assume that string connecting meter stick with pulley always remains vertical.

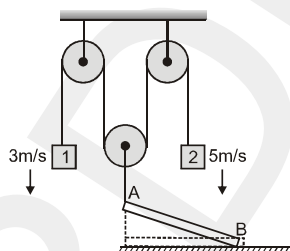

6. If blocks 1 and 2 are given constant speeds as shown then the distance moved by end B over the floor in the period for which speed of B is less than A.
- (A) $\left(\frac{\sqrt{2}+1}{\sqrt{2}}\right)$ m (B) $\left(\frac{\sqrt{2}-1}{\sqrt{2}}\right)$ m (C) $\frac{1}{\sqrt{2}}$ m (D) $\frac{1}{2}$ m
7. Time taken to cover the distance in above part is :
- (A) $\left(\frac{\sqrt{2}+1}{4\sqrt{2}}\right)$ sec (B) $\left(\frac{\sqrt{2}-1}{4\sqrt{2}}\right)$ sec (C) $\frac{1}{4\sqrt{2}}$ sec (D) $\frac{1}{8}$ sec
8. Minimum magnitude of relative velocity of A with respect to B during the motion specified in question 5 is :
- (A) 2 m/s (B) 4 m/s (C) 6 m/s (D) None of these

Topic : Friction

Type of Questions

Single choice Objective ('-1' negative marking) Q.1 to Q.4

(3 marks, 3 min.)

M.M., Min.

[12, 12]

Comprehension ('-1' negative marking) Q.5 to Q.7

(3 marks, 3 min.)

[9, 9]

1. A force $F = 2t$ (where t is time in seconds) is applied at $t = 0$ sec. to the block of mass m placed on a rough horizontal surface. The coefficient of static and kinetic friction between the block and surface are μ_s and μ_k respectively. Which of the following graphs best represents the acceleration vs time of the block. ($\mu_s > \mu_k$)

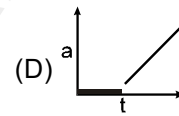
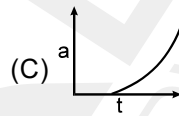
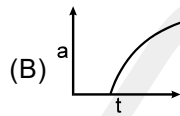
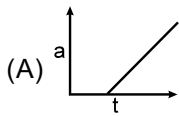
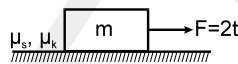

2. A body of mass m is kept on a rough fixed inclined plane of angle of inclination $\theta = 30^\circ$. It remains stationary. Then magnitude of force acting on the body by the inclined plane is equal to:

(A) mg (B) $mg \sin \theta$ (C) $mg \cos \theta$ (D) none of these

3. A body of mass 10 kg lies on a rough inclined plane of inclination $\theta = \sin^{-1} \frac{3}{5}$ with the horizontal. When a force of 30 N is applied on the block parallel to & upward the plane, the total reaction by the plane on the block is nearly along:

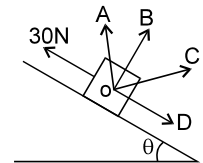

(A) OA (B) OB (C) OC (D) OD

4. A 1 kg block is being pushed against a wall by a force $F = 75$ N as shown in the Figure. The coefficient of friction is 0.25. The magnitude of acceleration of the block is:

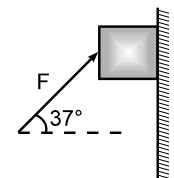

(A) 10 m/s^2 (B) 20 m/s^2 (C) 5 m/s^2 (D) none

COMPREHENSION

Figure shows an arrangement of pulleys and two blocks. All surfaces are frictionless. All pulleys and strings are massless. All strings are smooth and massless.

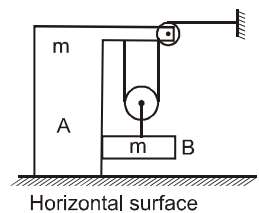

5. The acceleration of block A is :

(A) $\frac{2g}{9}$ (B) $\frac{g}{9}$ (C) $\frac{g}{5}$ (D) None of these

6. Normal reaction between A and ground is :

(A) mg (B) $\frac{17mg}{9}$ (C) $\frac{16mg}{9}$ (D) None of these

7. Normal reaction between A and B is :

(A) mg (B) $\frac{mg}{9}$ (C) $\frac{2mg}{9}$ (D) None of these

DPP 21 TO 30 ANSWER KEY

DPP NO. - 21

1. (A) 2. (C) 3. (A) 4. (D) 5. (A)
6. (A) 7. (D) 8. (C)

DPP NO. - 22

1. (A) 2. (A) 3. (A) 4. (D) 5. (A)
6. (C) 7. (A), (B), (C) 8. (B), (C)

DPP NO. - 23

1. (D) 2. (A) 3. (D) 4. (B) 5. (A)
6. (A,D)

DPP NO. - 24

1. (B) 2. (B) 3. (D) 4. (B) 5. (A)
6. (D) 7. (i) False (ii) True
8. (i) 24 N (ii) 108 N

DPP NO. - 25

1. (D) 2. (A) 3. (B)
4. (A) 5. $T = \frac{m_1 m_2 g \sin(\alpha - \beta)}{m_1 \cos \alpha + m_2 \cos \beta}$ 6. (A)
7. (B) 8. (D)

DPP NO. - 26

1. (D) 2. (A) 3. (C) 4. (A) 5. (C)

6. (A) (B) (D) 7. $F = \frac{mg}{\sqrt{1 - \left(\frac{m}{m+M}\right)^2}}$
8. $\frac{d\theta}{dt} = \frac{1}{1+t^2}$

DPP NO. - 27

1. (D) 2. (A) (B) (D) 3. 0.5 sec.
4. (C) 5. (C) 6. (A)

DPP NO. - 28

1. (C) 2. (A) 3. (B) 4. (B)
5. (A) (B) (C) (D) 6. (A) (B) (C)

7. (a) $T = mg, x = \frac{2mg}{K}$;
(b) $T_1 = mg, T_2 = 2mg, x = \frac{mg}{K}$;
(c) $T_1 = mg, T_2 = 2mg, x = \frac{mg}{K}$;
(d) $T = mg, x = \frac{2mg}{K}$; (e) $T = 2mg, x = \frac{mg}{K}$

DPP NO. - 29

1. (A) 2. (D) 3. (B) 4. $\theta = \frac{\pi}{4}$
5. (i) yes (ii) depends upon path (iii) yes (iv) no
(v) limiting friction needs to be overcome to make body move
(vi) N is larger
6. (B) 7. (C) 8. (B)

DPP NO. - 30

1. (D) 2. (A) 3. (A) 4. (B) 5. (A)
6. (B) 7. (C)



GGSRDN

Educational Services Private Limited

9th, 10th, NEET, JEE(Main/Advanced)

अभ्यास ही सबसे बड़ा गुरु है।

CLASS : XI (PHYSICS)

D P P P

DAILY PRACTICE PROBLEM

Solutions

DPP-21 TO 30

DPP 21 : Relative Motion, Projectile Motion, Newton's Law of Motion

DPP 22 : Newton's Law of Motion, Rectilinear Motion, Projectile Motion

DPP 23 : Newton's Law of Motion, Relative Motion

DPP 24 : Relative Motion, Newton's Law of Motion, Projectile Motion

DPP 25 : Newton's Law of Motion

DPP 26 : Newton's Law of Motion, Relative Motion, Projectile Motion, Rectilinear Motion

DPP 27 : Relative Motion, Newton's Law of Motion

DPP 28 : Relative Motion, Newton's Law of Motion

DPP 29 : Friction, Newton's Law of Motion

DPP 30 : Friction

DPP NO. - 21

1.

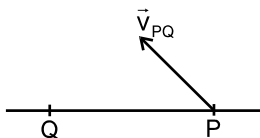

Q measures acceleration of P to be zero.

∴ Q measures velocity of P, i.e. \vec{v}_{PQ} , to be constant.

Hence Q observes P to move along straight line.

∴ For P and Q to collide Q should observe P to move along line PQ.

Hence PQ should not rotate.

2. Let initial and final speeds of stone be u and v .

$$\therefore v^2 = u^2 - 2gh \quad \dots\dots(1)$$

$$\text{and } v \cos 30^\circ = u \cos 60^\circ \quad \dots\dots(2)$$

solving 1 and 2 we get $u = \sqrt{3gh}$

3. Flag will flutter in the direction of wind and opposite to the direction of velocity of man

i.e. in the direction of V_{wm}

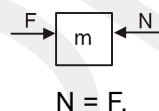
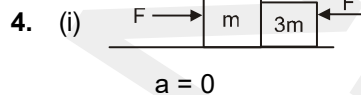
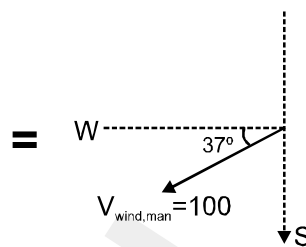
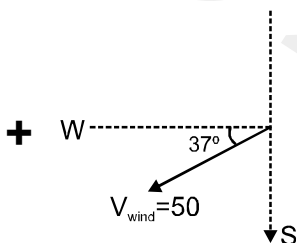
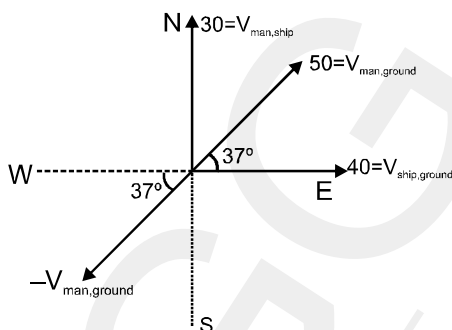

$$a = \frac{2F}{4m} = \frac{F}{2m}$$

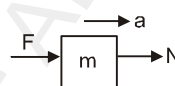

$$F - N = ma$$

$$N = F - m \left(\frac{F}{2m} \right) = \frac{F}{2}$$



$$a = \frac{3F}{4m}$$

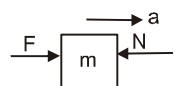

$$F - N = ma$$

$$N = F - ma$$

$$N = F - m \left(\frac{3F}{4m} \right)$$

$$N = \frac{F}{4}$$

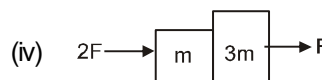

$$a = \frac{3F}{4m}$$

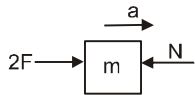

$$2F - N = ma \quad N = 2F - m\left(\frac{3F}{4m}\right)$$

$$N = \frac{5F}{4}$$

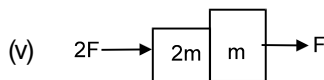

$$a = \frac{3F}{3m} = \frac{F}{m}$$

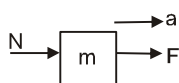

$$N + F = ma \quad N + F = m\left(\frac{F}{m}\right)$$

$$N = 0.$$

5. F.B.D. of block

$$N^2 = F^2 + (mg)^2$$

$$N = 10\sqrt{2} \text{ N}$$

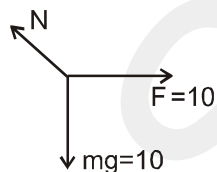

6. $AB = 2R \cos\theta$

acceleration along AB

$$a = g \cos\theta$$

$u = 0$ from A to B

$$S = ut + \frac{1}{2} at^2$$

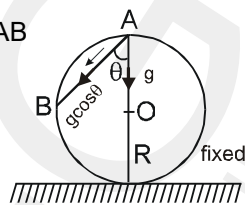

$$2R \cos\theta = 0 + \frac{1}{2} (g \cos\theta) t^2$$

$$t = 2 \sqrt{\frac{R}{g}}$$

7. Unit vector in direction of (1,0,0) to (4,4,12) is

$$\frac{(4-1)\hat{i} + (4-0)\hat{j} + (12-0)\hat{k}}{13}$$

Hence position of particle at $t = 2$ sec is : $\vec{r}_f = \vec{r}_i + \vec{v} \times 2$

$$= 31\hat{i} + 40\hat{j} + 120\hat{k}$$

8. $a = \frac{F}{m} \quad V^2 = u^2 + 2as \quad (u = 0)$

$$V \propto \sqrt{2\left(\frac{F}{m}\right)S} \quad V \propto \frac{1}{\sqrt{m}}$$

DPP NO. - 22

1. From geometry :

$$\cos\theta = \frac{3}{5}$$

$$\sin\theta = \frac{4}{5}$$

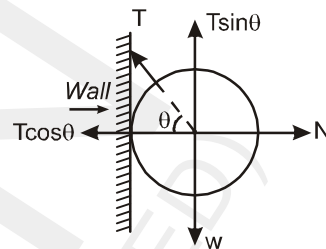

As sphere is at equilibrium,

$$T \sin\theta = w$$

$$T\left(\frac{4}{5}\right) = w$$

$$T = \frac{5w}{4}$$

2. Resolving forces at point A along string AB

$$w_1 \cos 37^\circ = w_2$$

$$\frac{w_1}{w_2} = \frac{5}{4}$$

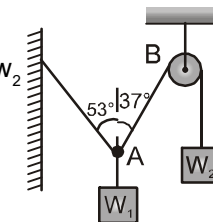

3. $v = 0 \Rightarrow x^2 - 5x + 4 = 0$

$$x = 1 \text{ m \& } 4 \text{ m}$$

$$\frac{dv}{dt} = (2x - 5) v = (2x - 5) (x^2 - 5x + 4)$$

$$\text{at } x = 1 \text{ m \& } 4 \text{ m ; } \frac{dv}{dt} = 0$$

4. $a = \left(\frac{5-4}{5+4}\right)g = \frac{g}{9}$

$$T - mg = ma$$

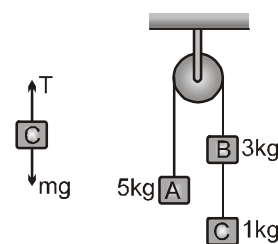

$$T = m(g + a)$$

$$= 1 \left(g + \frac{g}{9} \right) = \frac{10g}{9}$$

5. Time taken by ball from O to A is same as that from A to B.

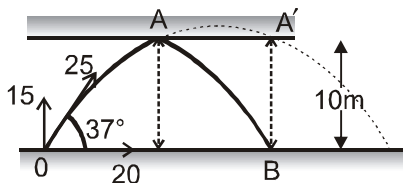

$$10 = 15t - \frac{1}{2}(10)t^2$$

$$5t^2 - 15t - 10 = 0$$

$$t^2 - 3t - 2 = 0$$

$$t = 1, 2$$

$t = 2$ is invalid as it is the time taken by the ball to come at A' if there was no roof.

$\therefore t = 1$ seconds.

During this the ball will travel $V \times t = 20 \times 2 = 40$ m on the floor.

- 6.

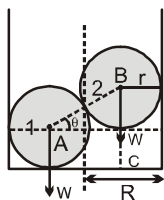

$$r = 5\text{cm} ; R = 8\text{cm}$$

FBD of sphere 1

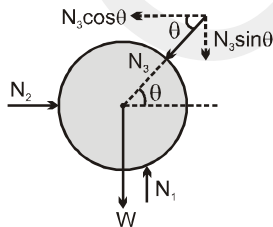

$$N_1 = W + N_3 \sin \theta$$

$$N_2 = N_3 \cos \theta$$

FBD of sphere 2

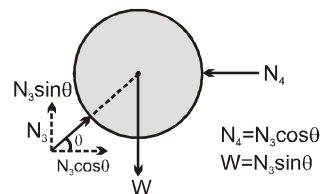

$$AC = 2R - 2r$$

$$AB = 2r$$

$$\cos \theta = \frac{AC}{AB} = \frac{R-r}{r}$$

$$N_4 = N_3 \cos \theta$$

$$W = N_3 \sin \theta$$

Ans. $N_4 = W \cot \theta$

$$N_3 = W \operatorname{cosec} \theta$$

$$N_2 = W \cot \theta$$

$$N_1 = 2W.$$

7. $\Rightarrow 0.2g = 0.7a$

$$\Rightarrow a = \frac{2g}{7} \text{ m/s}^2$$

For the case, it comes to rest when $V = 0$

$$0 = 7 + \left(-\frac{2g}{7} \right) t \Rightarrow t = \frac{49}{2g} = 2.5 \text{ s}$$

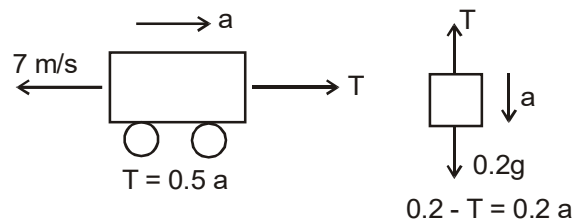

Distance travelled till it comes to rest

$$0 = 7^2 + 2 \left(-\frac{2g}{7} \right) s$$

$$S = 8.75 \text{ m}$$

So in next 2.5s, it covers 8.75 m towards right.

Total distance = $2 \times 8.75 = 17.5$ m

After 5s, its speed will be same as that of initial (7 m/s) but direction will be reversed.

8. Acceleration of system $a = \frac{F}{m_A + m_B + m_C}$

$$a = \frac{60}{10 + 20 + 30} = 1 \text{ m/s}^2$$

FBD of A :

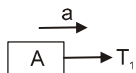

$$T_1 = m_A \cdot a$$

$$T_1 = 10(1) = 10\text{N}$$

FBD of B :

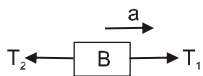

$$T_2 - T_1 = m_B a$$

$$T_2 - 10 = 20(1)$$

$$T_2 = 30\text{ N.}$$

DPP NO. - 23

1. for (man + platform) system :
 $2mg - 4T = 2m(a)$

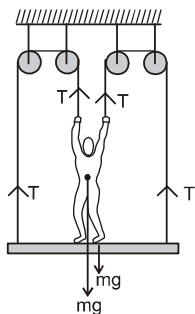

$$\Rightarrow 2mg - 4 \left(\frac{mg}{2} \right) = 2m(a) \quad [\because T = \frac{mg}{2}]$$

$$\Rightarrow a = 0$$

2. Let $a =$ acceleration of m_1

then acceleration of pulley = $\frac{a+0}{2} = \frac{a}{2}$

If acceleration of $m_2 = b$

Then $0 + \frac{b}{2} = \frac{a}{2}$

Hence $a = b$

$$T = m_1 a, \quad m_2 g - T = m_2 a$$

$$\therefore a = \frac{m_2 g}{m_1 + m_2}$$

3. **Method - I**

As cylinder will remain in contact with wedge A

$$V_x = 2u$$

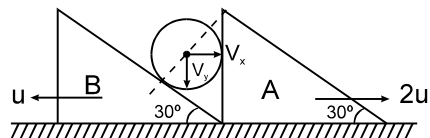

As it also remain in contact with wedge B
 $u \sin 30^\circ = V_y \cos 30^\circ - V_x \sin 30^\circ$

$$V_y = V_x \frac{\sin 30^\circ}{\cos 30^\circ} + \frac{U \sin 30^\circ}{\cos 30^\circ}$$

$$V_y = V_x \tan 30^\circ + u \tan 30^\circ$$

$$V_y = 3u \tan 30^\circ = \sqrt{3} u$$

$$V = \sqrt{V_x^2 + V_y^2} = \sqrt{7} u \text{ Ans.}$$

Method - II

In the frame of A

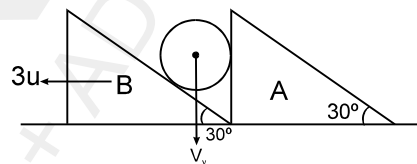

$$3u \sin 30^\circ = V_y \cos 30^\circ$$

$$\Rightarrow V_y = 3u \tan 30^\circ = \sqrt{3} u$$

and $\circ V_x = 2u$

$$\Rightarrow V = \sqrt{V_x^2 + V_y^2} = \sqrt{7} u \text{ Ans.}$$

4. $l_1 + 2l_2 = \text{constant}$

$$\therefore \frac{dl_1}{dt} + \frac{2dl_2}{dt} = 0$$

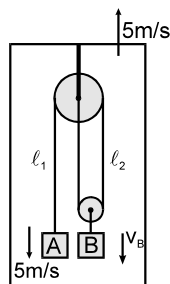

$$(5 + 5) + 2(5 + v_b) = 0 \text{ or } v_b = 10 \text{ m/s}$$

5. Assume that acceleration of particle is a_p

and acceleration of wedge is a_w

Then, $a_w = g \sin \theta$

From wedge constant

$$a_p = a_w \sin \theta = g \sin^2 \theta$$

$$h = \frac{1}{2} g \sin^2 \theta t^2$$

$$t = \sqrt{\frac{2h}{g \sin^2 \theta}}$$

6. From Newton's third law, the force exerted by table on block is equal to that exerted by block on the table. Therefore block exerts a 10 N force on table. Since the upward force on the block is larger than downward force, it moves upwards.

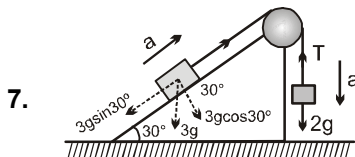

FBD of block $M_2 = 2\text{ kg}$



$$20 - T = 2a \quad \dots\dots\dots(i)$$

FBD of block $M_1 = 3\text{ kg}$

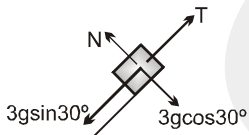

$$= 3 \times \frac{10\sqrt{3}}{2}$$

$$= 15\sqrt{3} \text{ N.}$$

$$= 15 \text{ N}$$

$$T - 15 = 3a \quad \dots\dots\dots(ii)$$

$$(i) + (ii)$$

$$5 = 5a$$

$$\Rightarrow a = 1\text{ m/s}^2 \quad ; \quad T = 18 \text{ N.}$$

8. (i) $a = \frac{2mg - mg}{3m} = \frac{g}{3}$

(ii) $a = \frac{2mg - mg}{m} = g$

(iii) $a = \frac{2mg}{m} = 2g$

(iv) $a = \frac{2g}{3}$

DPP NO. - 24

1.

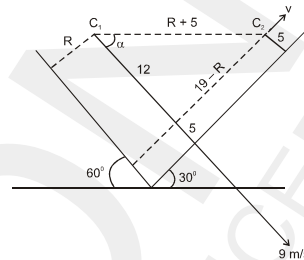

$$9 \cos \alpha = v \sin \alpha \quad \rightarrow \quad (i)$$

$$\frac{19 - R}{12} = \tan \alpha \quad \rightarrow \quad (ii)$$

$$(R + 5)^2 = (12)^2 + (19 - R)^2$$

$$\Rightarrow R = 10$$

Hence from (i) and (ii)

$$v = 12 \text{ m/s}^2$$

2. Acceleration of boy and block will be same equal to 1.25 m/s^2 w.r.t. ground. Hence

$$10 = \frac{1}{2} (1.25) t^2$$

$$\Rightarrow t = 4 \text{ sec.}$$

3. From constraint relation, if acceleration of mass B is a then acceleration of mass A will be $a/2$:

FBD of A :

$$T - mg = \frac{ma}{2} \quad \dots\dots\dots(i)$$

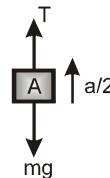

FBD of B :

$$mg - \frac{T}{2} = ma \quad \dots\dots\dots(ii)$$

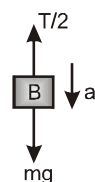

From (i) & (ii)

$$a = \frac{2g}{5}$$

4. $x = 4y^2$

$$\frac{dx}{dt} = 8y \frac{dy}{dt}$$

$$V_x = 8y V_y$$

$$V_x = 4$$

$$a_x = 0$$

$$0 = a_x = 8[y \cdot a_y + V_y^2]$$

$$-y a_y = V_y^2$$

$$|a_y| = \frac{v_y^2}{y}$$

$$|a_y| = \frac{v_x^2}{64y^3} = \frac{16}{64 \times y^3}$$

at $y = 1 \Rightarrow |a_y| = \frac{1}{4}$

$y = 1 \Rightarrow |a_y| = \frac{1}{4}$

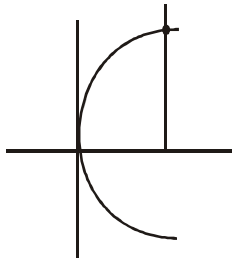

5.

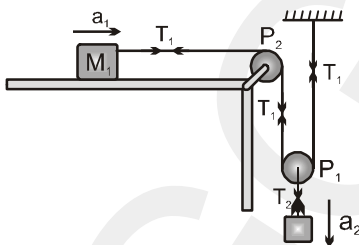

Relative between a_1 & a_2

$$a_1 = 2a_2 = 2a$$

Relative between T_1 & T_2

$$T_2 = 2T_1 = 2T$$

$$T_1 = M_1 a_1 \dots\dots\dots (i)$$

$$M_2 g - T_2 = M_2 a_2 \dots\dots\dots (ii)$$

$$2T = 4M_1 a$$

$$M_2 g - 2T = M_2 a$$

$$M_2 g = a(4M_1 + M_2) \Rightarrow a = \frac{M_2 g}{4M_1 + M_2}$$

6.

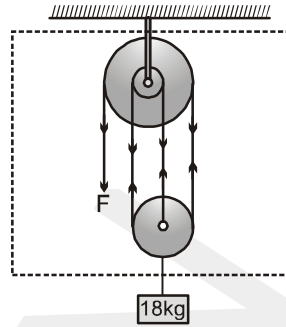

$$3F = 180$$

$$F = 60 \text{ N}$$

$$T = 4F = 240 \text{ N}$$

Force balance on system

$$T = F + 180$$

$$T = 60 + 180 = 240 \text{ N.}$$

7. False There acceleration may be different.

True $T = \frac{W}{V}$ to minimize T, V will be maximum.

i.e whole effort of swimmer must towards opposite bank.

8. (i) FBD of 2kg

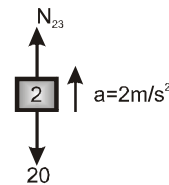

$$N_{23} - 20 = 2(2)$$

$$N_{23} = 24 \text{ N}$$

(ii) FBD of 3 kg

$$N_{34} - N_{23} - 30 = 3(2)$$

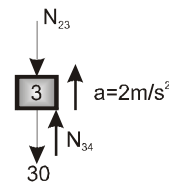

$$N_{34} = N_{23} + 30 + 6$$

$$N_{34} = 24 + 30 + 6 = 60 \text{ N}$$

FBD of 4kg

$$N_G - N_{34} - 40 = 4(2)$$

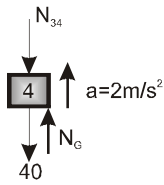

$$N_G = N_{34} + 40 + 8$$

$$N_G = 60 + 40 + 8 = 108 \text{ N}$$

DPP NO. - 25

1. Acceleration of two mass system is $a = \frac{F}{2m}$

leftward

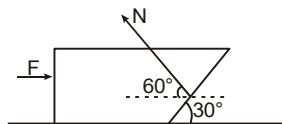

FBD of block A

$$N \cos 60^\circ - F = ma = \frac{mF}{2m} \text{ solving } N = 3F$$

2. Since, $h = \frac{1}{2}at^2 \Rightarrow a$ should be same in both cases, because h and t are same in both cases as given.

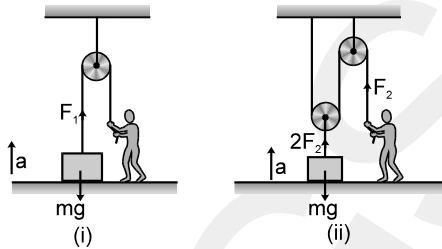

In (i) $F_1 - mg = ma$

$\Rightarrow F_1 = mg + ma$

In (ii) $2F_2 - mg = ma$

$\Rightarrow F_2 = \frac{mg + ma}{2} \therefore F_1 > F_2$

3. $l_1 + l_2 + l_3 = \text{constant}$

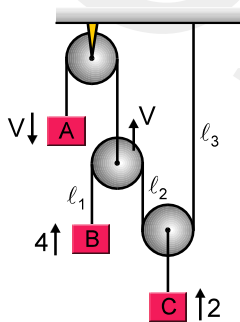

$\dot{l}_1 + \dot{l}_2 + \dot{l}_3 = 0$

$(V - 4) + (V - 2) + (-2) = 0$

$\Rightarrow 2V = 8$

$\Rightarrow V = 4 \text{ m/s } \downarrow$

4. In this case spring force is zero initially F.B.D. of A and B

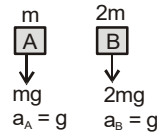

5. If the block has an acceleration towards right, the blocks would have some acceleration towards left.

Resolving horizontally and vertically, we have

$R_2 = m_2 g \cos \beta + m_2 f \sin \beta \dots (1)$

$m_2 f = T \cos \beta + R_2 \sin \beta \dots (2)$

and

$R_1 = m_1 g \cos \alpha + m_1 f \sin \alpha \dots (3) \quad m_1 f = R_1 \sin \alpha - T \cos \alpha \dots (4)$

From equation (2) and (1), we get

$m_2 f = T \cos \beta + [m_2 g \cos \beta + m_2 f \sin \beta] \sin \beta$

$= T \cos \beta + m_2 g \cos \beta \sin \beta + m_2 f \sin^2 \beta$

$\therefore T \cos \beta = m_2 f - m_2 f \sin^2 \beta - m_2 g \cos \beta \sin \beta$

or $T \cos \beta = m_2 f \cos^2 \beta - m_2 g \cos \beta \sin \beta$

or $T = m_2 f \cos \beta - m_2 g \sin \beta \dots (5)$

From equations (3) and (4), we have

$m_1 f = (m_1 g \cos \alpha + m_1 f \sin \alpha) \sin \alpha - T \cos \alpha$

$= m_1 g \cos \alpha \sin \alpha + m_1 f \sin^2 \alpha - T \cos \alpha$

$\therefore T \cos \alpha = m_1 g \cos \alpha \sin \alpha + m_1 f (\sin^2 \alpha - 1)$

or $T = m_1 g \sin \alpha - m_1 f \cos \alpha \dots (6)$

Equating (5) and (6), we get

$m_2 f \cos \beta - m_2 g \sin \beta = m_1 g \sin \alpha - m_1 f \cos \alpha$

$\therefore f = g \left[\frac{(m_1 \sin \alpha + m_2 \sin \beta)}{(m_2 \cos \beta + m_1 \cos \alpha)} \right] \dots (7)$

Substituting the value of f in eqn. (6), we get

$T = m_1 g \sin \alpha - m_1 g$

$\left\{ \frac{(m_1 \sin \alpha + m_2 \sin \beta)}{(m_2 \cos \beta + m_1 \cos \alpha)} \right\} \cos \alpha$

Simplifying, we get

$T = \frac{m_1 m_2 g \sin(\alpha - \beta)}{m_1 \cos \alpha + m_2 \cos \beta} \text{ Ans.}$

(6 to 8). free body diagram 'C' block

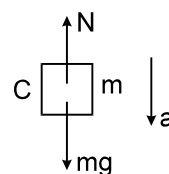

$mg - N = ma$

$$\therefore N = m \left(g - \frac{gm}{2M+m} \right) \quad N = \frac{2Mmg}{2M+m}$$

7. $T - mg = M \frac{mg}{2M+m}$ for A block

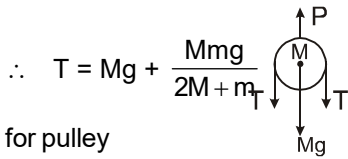

for pulley

$$P = 2T + Mg$$

$$= 2Mg + \frac{2Mmg}{2M+m} + Mg = \frac{6M+3m+2m}{2M+m} Mg$$

$$P = \left(\frac{6M+5m}{2M+m} \right) Mg$$

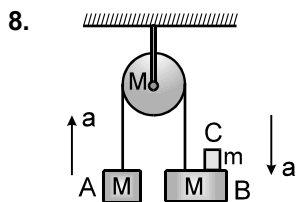

By newtons law on system of (A, B, C)

5. $(M + m - m)g = (2M + m)a$

$$\therefore a = \frac{mg}{2M+m}$$

DPP NO. - 26

1. FBD of man of mass (m)

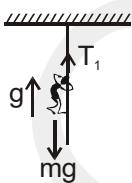

$$T_1 = mg + mg$$

$$T_1 = 2mg$$

$$\Rightarrow T_1 : T_2 :: 8 : 3$$

FBD of man of mass (m/2)

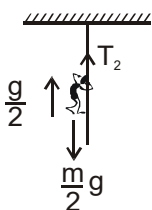

$$T_2 = \frac{m}{2}g + \frac{m}{2} \cdot \frac{g}{2}$$

$$T_2 = \frac{mg}{2} \left[\frac{3}{2} \right] = \frac{3mg}{4}$$

2.

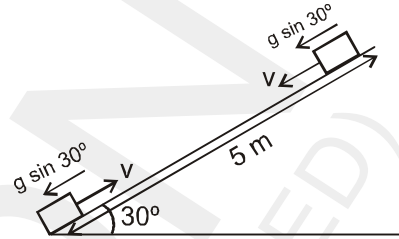

Down the plane $5 = v \cdot t + \frac{1}{2} (g \sin \theta) t^2 \dots (1)$

at the plane $0 = v - g \sin \theta t' \Rightarrow t' = \frac{v}{g \sin \theta}$

$t = 2t' = \frac{2v}{g \sin \theta}$ [time taken by B in coming back to initial position]

$$5 = \frac{2 \cdot v^2}{g \sin \theta} + \frac{1}{2} \frac{g \sin \theta \cdot 4v^2}{g^2 \sin^2 \theta}$$

$$10 g \sin \theta = 8v^2$$

$$v = \sqrt{\frac{10 \times 10 \times \left(\frac{1}{2} \right)}{8}} = \sqrt{\frac{100}{16}} = \frac{10}{4} = 2.5 \text{ m/sec}$$

3.

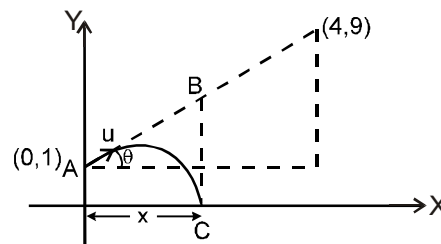

$$\tan \theta = \frac{9-1}{4-0} = 2$$

$$y = u_y t + \frac{1}{2} a_y t^2$$

now $-1 = u \sin \theta (1) - \frac{1}{2} g (1)^2$

$$u \sin \theta = 4 \quad \text{and} \quad \sin \theta = \frac{2}{\sqrt{5}}$$

$$\Rightarrow u = 2\sqrt{5}$$

now, $x = u \cos\theta (1) = (2\sqrt{5}) \times \frac{1}{\sqrt{5}} = 2\text{m}$

4. Before cutting the spring

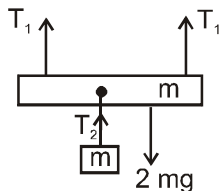

$$T_2 = mg$$

After cutting the spring

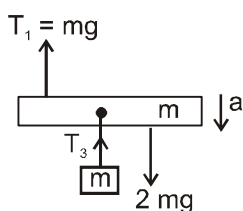

$$2mg - mg = 2ma$$

$$a = g/2$$

$$T_3 = mg/2$$

$$T_2 - T_3 = mg - \frac{mg}{2} = \frac{mg}{2}$$

5. The free body diagram of cylinder is as shown.

Since net acceleration of cylinder is horizontal,

$$N_{AB} \cos 30^\circ = mg$$

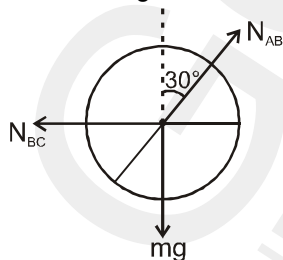

$$\text{or } N_{AB} = \frac{2}{\sqrt{3}} mg \quad \dots (1)$$

$$\text{and } N_{BC} - N_{AB} \sin 30^\circ = ma$$

$$\text{or } N_{BC} = ma + N_{AB} \sin 30^\circ \quad \dots (2)$$

Hence N_{AB} remains constant and N_{BC} increases with increase in a .

6. For $t = 0$ to $t = 10$.

$$V = u + at$$

$$V = 0 + (1) (10) = 10 \text{ m/s.}$$

$$a = 2t$$

$$\int_{10}^v dv = 2 \int_{10}^{20} t dt \quad \dots (1)$$

$$v - 10 = 2 \left[\frac{t^2}{2} \right]_{10}^{20}$$

$$v - 10 = (20)^2 - (10)^2 = 300$$

$$v = 310 \text{ m/s.}$$

(b) For $t = 0$ to $t = 10 \text{ s.}$

$$S = ut + \frac{1}{2} at^2$$

$$\Rightarrow S = (0) (10) + \frac{1}{2} \times 1 \times (10)^2 = 50 \text{ m}$$

From (1)

$$v - 10 = t^2 - (10)^2$$

$$v = t^2 - 90$$

$$\int_{50}^s ds = \int_{10}^{20} (t^2 - 90) dt$$

$$S - 50 = \left[\frac{(20)^3}{3} - 90 \times 20 \right] - \left[\frac{(10)^3}{3} - 90 \times 10 \right]$$

$$S = 50 + \frac{8000}{3} - 1800 - \frac{1000}{3} + 900$$

$$S = 50 + \frac{7000}{3} - 900$$

$$\Rightarrow S = 1483.33 \text{ m}$$

7. A force F is applied on block A of mass M so that the tension in light string also becomes F when block B of

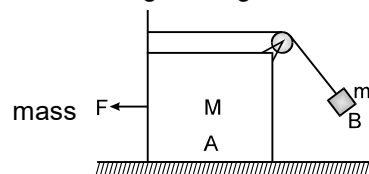

Applying Newton's law on the system in horizontal direction $F = (M + m) a$.

Now consider the equilibrium of block B w.r.t. block M

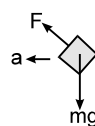

$$F^2 = (mg)^2 + (ma)^2 = (mg)^2 + \left(m \frac{F}{m+M} \right)^2$$

$$\therefore F^2 = \frac{m^2 g^2}{1 - \frac{m^2}{(m+M)^2}}$$

$$F = \frac{mg}{\sqrt{1 - \left(\frac{m}{m+M}\right)^2}}$$

8. At any time t, rain will appear to the boy as shown in picture.

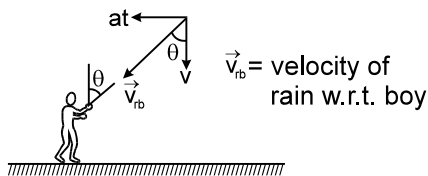

$$\tan \theta = \frac{at}{v}$$

Boy should hold his umbrella at an angle θ from the vertical

$$\therefore \tan \theta = \frac{at}{v} \quad \sec^2 \theta \frac{d\theta}{dt} = \frac{a}{v}$$

$$\Rightarrow \frac{d\theta}{dt} = \frac{a}{v \sec^2 \theta} = \frac{a}{v[1 + \tan^2 \theta]}$$

$$= \frac{a}{v \left[1 + \frac{a^2 t^2}{v^2} \right]} = \frac{av}{v^2 + a^2 t^2} = \frac{2 \times 2}{4 + 4t^2} = \frac{1}{1 + t^2}$$

$$\frac{d\theta}{dt} = \frac{1}{1 + t^2} \quad \text{Ans.} \quad \frac{d\theta}{dt} = \frac{1}{1 + t^2}$$

DPP NO. - 27

1. Time taken to reach the ground is given by

$$h = \frac{1}{2} g t^2 \quad \dots (1)$$

Since horizontal displacement in time t is zero

$$\therefore t = \frac{2v}{f} \quad \dots (2)$$

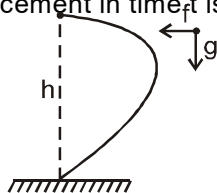

$$h = \frac{2gv^2}{f^2}$$

2.

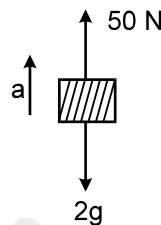

$$50 - 2g = 2a$$

$$\frac{50 - 19.6}{2} = a$$

$$a = 15.2 \text{ m/sec}^2 \text{ upwards}$$

As the acceleration of both the masses is upward.

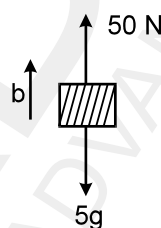

$$\text{and also ; } 50 - 5g = 5b$$

$$\frac{50 - 5 \times 9.8}{2} = b$$

$$b = \frac{50 - 49}{5} = 0.2 \text{ m/sec}^2 \text{ also upwards}$$

3. F.B.D. of A w.r.t. gravel

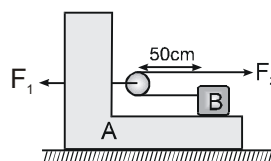

$$F_1 - 2F_2 = m_A a_A$$

$$\Rightarrow 20 - 2 \times 8 = 1 a_A$$

$$\Rightarrow a_A = 4 \text{ m/s}^2$$

F.B.D. of B w.r.t. A

$$\text{So } F_2 - m_A a_A = m_B a_{BA}$$

$$\Rightarrow 8 - 1 \times 4 = 1 a_{BA} \Rightarrow a_{BA} = 4 \text{ m/s}^2$$

4. For equi. of block (A)

$$F = N \sin \theta$$

$$N = F / \sin \theta$$

To lift block B from ground

$$N \cos \theta \geq mg$$

$$\frac{F}{\sin\theta} \cos\theta \geq mg$$

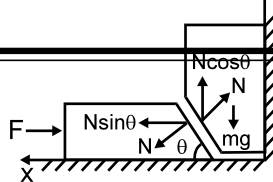

$$F \geq mg \tan\theta = mg \left(\frac{3}{4}\right)$$

$$\text{So } F_{\min} = \frac{3}{4} mg$$

5. If both the blocks are stationary,
 Balancing forces along x-direction
 $F = N \sin\theta \Rightarrow N = F/\sin\theta$

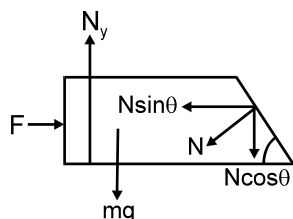

Balancing forces along y-direction

$$N_y = mg + N \cos\theta$$

$$= mg + \left(\frac{F}{\sin\theta}\right) \cos\theta = mg + F \cot\theta$$

$$N_y = mg + \frac{4F}{3}$$

6. To keep regular contact
 $a \sin\theta = b \cos\theta$

$$b = a \tan\theta = \frac{3}{4} a$$

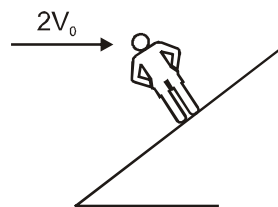
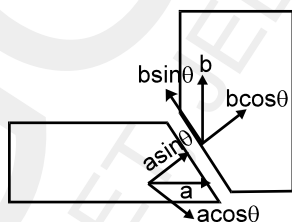

Velocity relative to man when it increase its speed to $2V_0$

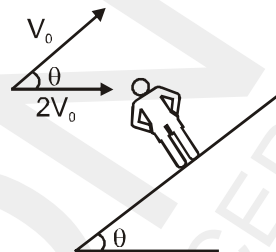

So resultant velocity of rain with respect to man

$$= \sqrt{(2V_0)^2 + (V_0)^2 + 4V_0^2 \cos 37^\circ} = \sqrt{\frac{41}{5}} V_0$$

3.

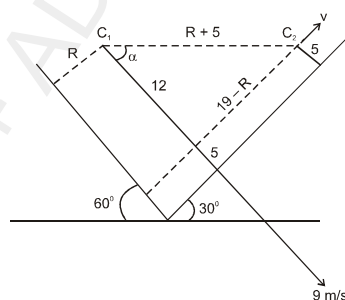

$$9 \cos\alpha = v \sin\alpha \rightarrow \text{(i)}$$

$$\frac{19-R}{12} = \tan\alpha \rightarrow \text{(ii)}$$

$$(R+5)^2 = (12)^2 + (19-R)^2 \quad [\text{Pythagorean}]$$

$$\Rightarrow R = 10$$

Hence from (i) and (ii) $v = 12 \text{ m/s}$

DPP NO. - 28

1. If component of velocity normal to incline are equal, time of flight is same. Also if horizontal components are equal, range on inclined plane will be equal for both.

2. Velocity of rain with respect to man initially as shown

4.

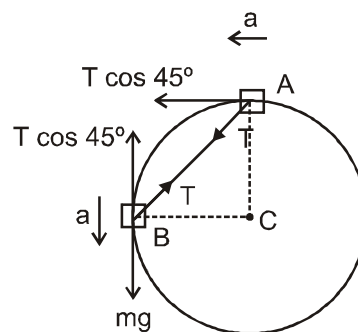

On block B :

$$mg - T \cos 45^\circ = ma \quad \dots\text{(i)}$$

on block A :

$$T \cos 45^\circ = ma \quad \dots(ii)$$

by equation (i) and (ii)

$$T = \frac{mg}{\sqrt{2}}$$

5. There is no horizontal force on block A, therefore it does not move in x-direction, whereas there is net downward force $(mg - N)$ is acting on it, making its acceleration along negative y-direction. Block B moves downward as well as in negative x-direction. Downward acceleration of A and B will be equal due to constrain, thus w.r.t. B, A moves in positive x-direction.

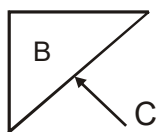

Due to the component of normal exerted by C on B, it moves in negative x-direction.

6. F.B.D. of block B w.r.t. wedge

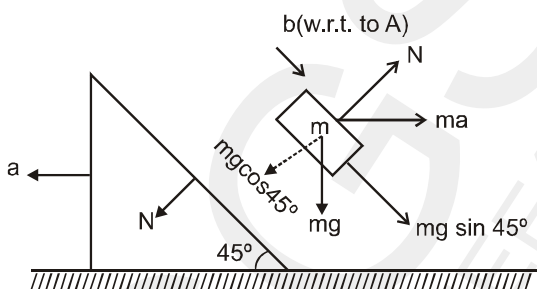

for block A

$$N \cos 45^\circ = 1.7 a \quad \dots(i)$$

for block B

$$0.6g \sin 45^\circ + 0.6a \cos 45^\circ = 0.6b \quad \dots(ii)$$

$$N + 0.6 a \cos 45^\circ = 0.6 g \cos 45^\circ \quad \dots(iii)$$

by solving (i), (ii) & (iii)

$$a = \frac{3g}{20} \text{ and } b = \frac{23g}{20\sqrt{2}}$$

Now vertical component of acceleration of

$$B = b \cos 45^\circ = \frac{23g}{40}$$

and horizontal component of acceleration of

$$B = b \sin 45^\circ - a = \frac{17g}{40}$$

7. (a) F.B.D. of m FBD

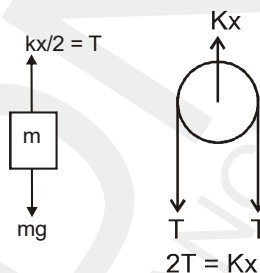
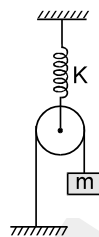

$$\frac{kx}{2} = mg \quad x = \frac{2mg}{k} \quad T = mg$$

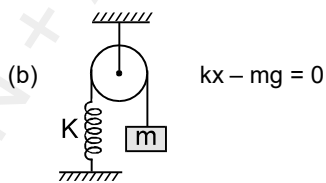

F.B.D of pulley

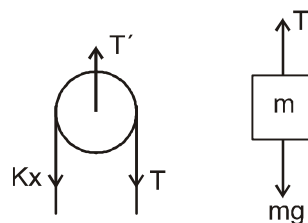

$$x = \frac{mg}{k} \quad T = kx \quad \therefore T = mg$$

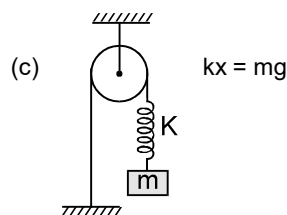

FBD of pulley

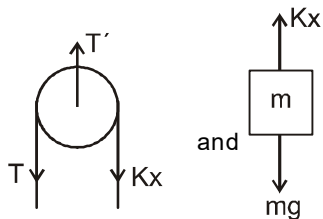

$$x = \frac{mg}{k} \quad T = mg$$

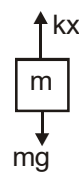

$$kx = mg \dots (2) \therefore x = \frac{mg}{k}$$

$$\text{By (1) \& (2) } T = 2mg$$

DPP NO. - 29

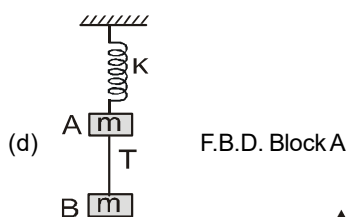

F.B.D. Block A

$$kx = mg + T \dots (1)$$

A

F.B.D. Block B

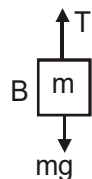

$$T = mg \dots (2)$$

$$\therefore kx = 2mg \quad x = \frac{2mg}{k}$$

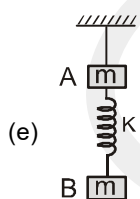

F.B.D. of Upper Block A

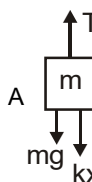

$$T = mg + kx \dots (1)$$

F.B.D. of Lower Block (B)

1. Sol. $f_k = \mu_k N = \mu_k mg \cos 30^\circ = mg \sin 30^\circ$

$$= 5(10) \left(\frac{1}{2} \right) \Rightarrow f_k = 25 \text{ N}$$

2. $N = mg = 40$

$$(f_s)_{\max} = \mu N = (0.8)(40) = 32$$

$$f_s = \text{ext. force} = 30$$

$$R^2 = N^2 + f_s^2 = (50)^2 \therefore R = 50 \text{ N}$$

3. FBD of block B w.r.t. wedge A, for maximum 'a' :

Perpendicular to wedge :

$$\Sigma f_y = (mg \cos \theta + m a \sin \theta - N) = 0.$$

$$\text{and } \Sigma f_x = mg \sin \theta + \mu N - ma \cos \theta = 0 \quad (\text{for maximum})$$

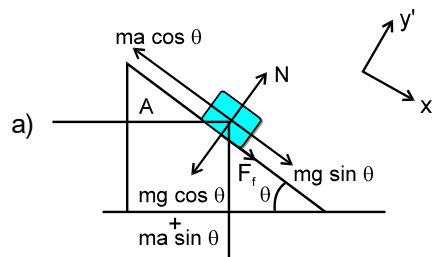

$$\Rightarrow mg \sin \theta + \mu(mg \cos \theta + ma \sin \theta) - ma \cos \theta = 0$$

$$\Rightarrow a = \frac{(g \sin \theta + \mu g \cos \theta)}{\cos \theta - \mu \sin \theta}$$

for $\theta = 45^\circ$

$$a = g \left(\frac{\tan 45^\circ + \mu}{\cot 45^\circ - \mu} \right) ; \quad a = g \left(\frac{1 + \mu}{1 - \mu} \right) \quad \text{Ans.}$$

4. By constraint velocity component of block along the string should be u

$$\Rightarrow v \cos \theta = u \quad \text{or} \quad v = u \sec \theta \dots (1)$$

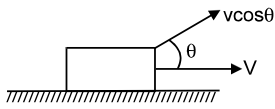

from (1) $a = \frac{dv}{dt} = u \sec \theta \tan \theta \frac{d\theta}{dt} \dots(2)$

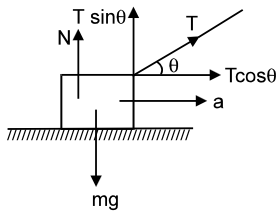

Initially when block is at a large distance θ is a small component of T in vertical direction is very small. As block comes nearer and nearer. T sin θ increases and N decreases.

When T sin $\theta = mg$ then block just loses contact with the ground

so T sin $\theta = mg \dots\dots\dots(3)$

T cos $\theta = ma \dots\dots\dots(4)$

(3) & (4) \Rightarrow

a tan $\theta = g \dots\dots\dots(5)$

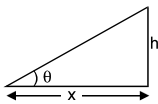

also, $x = h \cot \theta$

$\frac{dx}{dt} = -h \operatorname{cosec}^2 \theta \frac{d\theta}{dt}$

$\Rightarrow -v = -h \operatorname{cosec}^2 \theta \frac{d\theta}{dt}$ [as x is decreasing $\frac{dx}{dt} = -v$]

or $\frac{u \sec \theta}{h \operatorname{cosec}^2 \theta} = \frac{d\theta}{dt} \dots(\text{using (1)}) \dots(6)$

using (2), (5) and (6) we get

$u \sec \theta \tan \theta \left(\frac{u \sec \theta}{h \operatorname{cosec}^2 \theta} \right) \tan \theta = g$

putting values of u, h & g we get.

$\tan^4 \theta = 1 \Rightarrow \theta = \frac{\pi}{4}$

Ans. $\theta = \frac{\pi}{4}$

- 5. (i) yes
- (ii) depends upon path
- (iii) yes
- (iv) no

(v) limiting friction needs to be overcome to make body move

(vi) tension increases

(vii) N is larger]

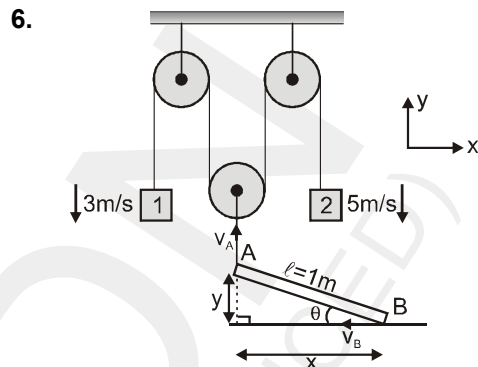

for any angle ' θ '

$x^2 + y^2 = l^2$

$\therefore 2xx' + 2yy' = 0$

$\therefore x(-v_B) + y(v_A) = 0$ i.e. $v_B = v_A \tan \theta$

or $v_B = 4 \tan \theta \dots(i)$

[as $v_A = \frac{3+5}{2} = 4 \text{ m/s}$]

from $v_B = v_A \tan \theta$

we can see that $v_B < v_A$ for $0 \leq \theta \leq \frac{\pi}{4}$

\therefore from $\theta = 0$ to $\theta = \frac{\pi}{4}$

distance moved by 'B' is

$d = 1 - x = 1 - \frac{1}{\sqrt{2}} = \left(\frac{\sqrt{2}-1}{\sqrt{2}} \right)$

[as $x = \frac{1}{\sqrt{2}}$ at $\theta = \frac{\pi}{4}$]

7. $t = \frac{x}{v_A} = \frac{1}{4\sqrt{2}} \text{ sec}$

8. $\vec{v}_A = 4\hat{j} \text{ m/s}$ and $\vec{v}_B = (-4 \tan \theta \hat{i}) \text{ m/s}$

$\therefore \vec{v}_{AB} = (4 \tan \theta \hat{i} + 4\hat{j}) \text{ m/s}$

$\therefore v_{AB} = 4 \sqrt{1 + \tan^2 \theta} = \frac{4}{\cos \theta}$

$\therefore (v_{AB})_{\min} = 4 \text{ m/s}$

DPP NO. - 30

1. Let t_0 be the time when friction force is maximum

$F = 2t_0 = \mu_s mg$

The block just starts moving immediately after this instant, with acceleration

$= \frac{\mu_s mg - \mu_k mg}{m} = (\mu_s - \mu_k) g$

For $t > t_0$ the acceleration of the block is

$a = \frac{2t_0 - \mu_k mg}{m}$

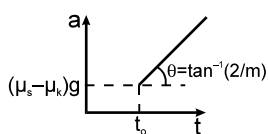

2. $N = mg \cos\theta$, $f_s = mg \sin\theta$

$R^2 = N^2 + f_s^2$

$\Rightarrow R = mg$ (A).

3. Frictional force along the in upward

direction = $10 g \sin\theta - 30 = 30 \text{ Nt}$

$N = \log \cos\theta = 80 \text{ Nt}$

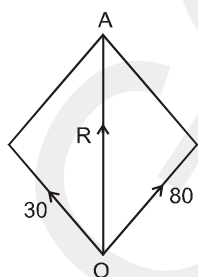

Direction of R is along OA.

- 4.

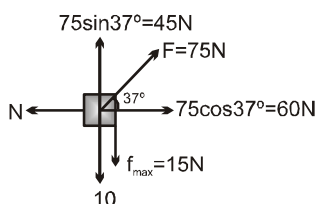

As the upward force (45N) is greater than total

downward force (25N) hence, it has an upward acceleration.

$\Sigma F_x = 0 \Rightarrow N = 60 \text{ N}$

$\Sigma F_y = ma_y$

$\Rightarrow 45 - 25 = (1)a$

$a = 20 \text{ m/s}^2$.

Sol.(5,6,7)

$T = 2ma$

$mg - 2T = \frac{ma}{2}$

$mg - 4ma = \frac{ma}{2}$

$mg = \frac{9ma}{2}$

$a = \frac{2g}{9}$

$T = \frac{4mg}{9}$

$N_1 = ma = \frac{2mg}{9}$

$N_2 = mg + 2T$

$N_2 = mg + 2T$

$= mg + \frac{8mg}{9} = \frac{17mg}{9}$.

