



GGSRDN

Educational Services Private Limited

9th, 10th, NEET, JEE(Main/Advanced)

अभ्यास ही सबसे बड़ा गुरु है।

CLASS : XII (PHYSICS)

DPP

DAILY PRACTICE PROBLEM

DPP-11 TO 21

- DPP 11 : Geometrical Optics, Fluid, Work, Power and Energy, Center of Mass, Circular Motion, Heat and Thermodynamics, Rigid Body Dynamics
- DPP 12 : Geometrical Optics., Rectilinear Motion, String Wave, Projectile Motion, Rigid Body Dynamics, Heat and Thermodynamics
- DPP 13 : Rigid Body Dynamics, Geometrical Optics, Simple Harmonic Motion, Center of Mass
- DPP 14 : Rigid Body Dynamics, Geometrical Optics, Simple Harmonic Motion, Work, Power and Energy, Electrostatics, Fluid
- DPP 15 : Topics : Electrostatics, Surface Tension, Friction, Simple Harmonic Motion, Thermal Expansion, Work, Power and Energy, Rigid Body Dynamics, Geometrical Optics
- DPP 16 : Electrostatics, Fluid, Circular Motion, Work, Power and Energy, Sound Wave, String Wave, Geometrical Optics
- DPP 17 : Rigid Body Dynamics, String Wave, Kinetic Theory of Gases, Thermal Expansion, Simple Harmonic Motion, Electrostatics
- DPP 18 : Calorimetry & Thermal Expansion, Electrostatics, Work, Power and Energy, Rigid Body Dynamics, String Wave, Geometrical Optics
- DPP 19 : Rigid Body Dynamics, Electrostatics, Kinematics, Sound Wave, Friction, Fluid
- DPP 20 : Geometrical Optics, Kinetic Theory of Gases, Rigid Body Dynamics, String Wave, Electrostatics, Center of Mass

Topics : Geometrical Optics, Fluid, Work, Power and Energy, Center of Mass, Circular Motion, Heat and Thermodynamics, Rigid Body Dynamics

Type of Questions

		M.M., Min.
Single choice Objective ('-1' negative marking) Q.1 to Q.5	(3 marks, 3 min.)	[15, 15]
Multiple choice objective ('-1' negative marking) Q.6 to Q.7	(4 marks, 4 min.)	[8, 8]
Subjective Questions ('-1' negative marking) Q.8	(4 marks, 5 min.)	[4, 5]
Comprehension ('-1' negative marking) Q.9 to Q.10	(3 marks, 3 min.)	[6, 6]

- An object moves in front of a fixed plane mirror. The velocity of the image of the object is
 (A) Equal in the magnitude and in the direction to that of the object.
 (B) Equal in the magnitude and opposite in direction to that of the object.
 (C) Equal in the magnitude and the direction will be either same or opposite to that of the object.
 (D) Equal in magnitude and makes any angle with that of the object depending on direction of motion of the object.
- A point object is moving along principal axis of a concave mirror with uniform velocity towards pole. Initially the object is at infinite distance from pole on right side of the mirror as shown. Before the object collides with mirror, the number of times at which the distance between object and its image is 40 cm are.



- (A) one time (B) two times (C) three times (D) Data insufficient
- Three containers of same base area, same height are filled with three different liquids of same mass as shown in the figure. If F_1, F_2, F_3 are the force exerted by the liquid on the base of the container in case I, II and III respectively, then we have the relation:

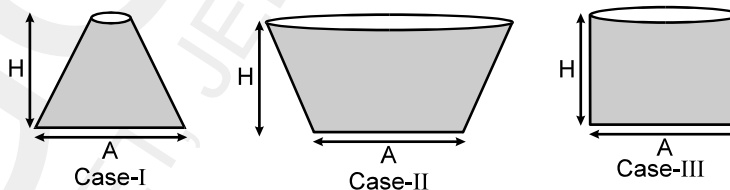

- (A) $F_1 = F_2 = F_3$ (B) $F_1 > F_2 > F_3$ (C) $F_3 > F_2 > F_1$ (D) $F_2 < F_3 < F_1$
- A particle is projected with a velocity u making an angle θ with the horizontal. The instantaneous power of the gravitational force
 (A) varies linearly with time (B) is constant throughout
 (C) is negative for complete path (D) None of the above

- A body of mass ' m ' sliding down a movable inclined plane of mass $2m$, assuming friction is absent everywhere the kinetic energy of $2m$ as a function of time is: (m remains on $2m$)

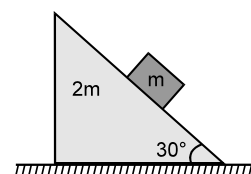

- (A) (B) (C) (D) none of these

6. A car is moving along a circle with constant speed on an inclined plane as shown in diagram. Then friction force on car may be in horizontal direction at least at one point :

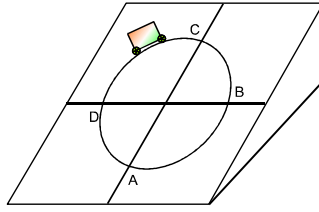

- (A) in portion 'AB' including point A and B
 (B) in portion 'BC' including point B and C
 (C) in portion 'CD' including point C and D
 (D) in portion 'DA' including point D and A

7. In a cyclic process, a gas is taken from state A to B via path-I as shown in the indicator diagram and taken back to state A from state B via path-II. In the complete cycle :

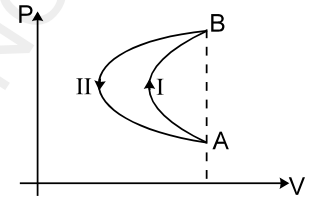

- (A) work is done on the gas.
 (B) heat is given to the gas
 (C) no work is done by the gas.
 (D) nothing can be said about work as data is insufficient

8. In the figure, an object is placed at distance 25 cm from the surface of a convex mirror, and a plane mirror is set so that the image formed by the two mirrors lie adjacent to each other in the same plane. The plane mirror is placed at 20 cm from the object. What is the radius of curvature of the convex mirror?

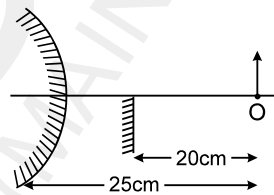

COMPREHENSION

A uniform ring of radius 4 cm placed on a rough horizontal surface is given a sharp impulse as in figure. As a consequence it acquires a linear velocity of 2 m/s. If coefficient of friction between the ring and the horizontal surface be 0.4. Then answer the following questions based on given information.

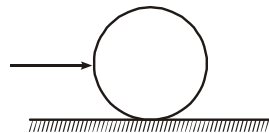

9. The velocity of centre of mass after which the ring will start pure rolling is -
 (A) 2 m/s (B) 1 m/s (C) 4 m/s (D) 1/2 m/s
10. The time after which the ring will start pure rolling is -
 (A) 1/2 s (B) 1 s (C) 1/4 s (D) 2 s

Topics : Geometrical Optics., Rectilinear Motion, String Wave, Projectile Motion, Rigid Body Dynamics, Heat and Thermodynamics

Type of Questions		M.M., Min.
Single choice Objective ('-1' negative marking) Q.1 to Q.4	(3 marks, 3 min.)	[12, 12]
Subjective Questions ('-1' negative marking) Q.5 to Q.7	(4 marks, 5 min.)	[12, 15]
Comprehension ('-1' negative marking) Q.8 to Q.10	(3 marks, 3 min.)	[9, 9]

1. Two plane mirrors are inclined to each other at 90° . A ray of light is incident on one mirror and the reflected light goes to the other mirror. The ray will undergo a total deviation of :
 (A) 180° (B) 90°
 (C) 45° (D) cannot be found because angle of incidence is not given.

2. AB is an incident beam of light and CD is a reflected beam (the number of reflections for this may be 1 or more than 1) of light. AB & CD are separated by some distance (may be large). It is possible by placing what type of mirror on the right side.

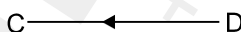

- (A) one plane mirror (B) one concave mirror
 (C) one convex mirror (D) none of these
3. A particle A of mass $\frac{10}{7}$ kg is moving in the positive direction of x. Its initial position is $x = 0$ & initial velocity is 1 m/s. The velocity at $x = 10$ is: (use the graph given)

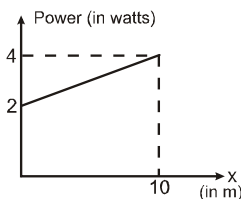

- (A) 4 m/s (B) 2 m/s
 (C) $3\sqrt{2}$ m/s (D) $100/3$ m/s

4. Two wave functions in a medium along x direction are given by -

$$y_1 = \frac{1}{2 + (2x - 3t)^2} \text{ m} \quad y_2 = -\frac{1}{2 + (2x + 3t - 6)^2} \text{ m}$$

where x is in metres and t is in seconds

- (A) There is no position at which resultant displacement will be zero at all times.
 (B) There is no time at which resultant displacement will be zero everywhere.
 (C) Both waves travel along the same direction.
 (D) Both waves travel in opposite directions.

5. A bullet is fired with speed 50 m/s at 45° angle find the height of the bullet when its direction of motion makes angle 30° with the horizontal.
6. A thin uniform rod AB of mass 'm' translates with an acceleration 'a', when two anti parallel forces F_1 and F_2 act on it as shown in figure. If the distance between F_1 and F_2 is 'b', the length of the bar is _____.

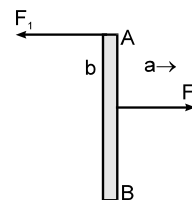

7. In the figure shown M_1 and M_2 are two spherical mirrors of focal length 20 cm each. AB and CD are their principal axes respectively which are separated by 1 cm. PQ is an object of height 2 cm and kept at distance 30 cm from M_1 . The separation between the mirrors is 50 cm. Consider two successive reflections first on M_1 then on M_2 . Find the size of the 2nd image. Also find distances of end points P'' and Q'' of that image from the line AB.

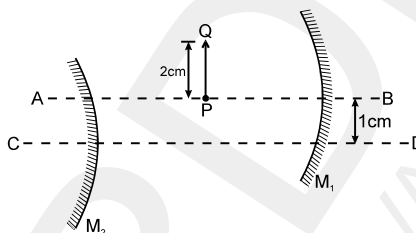

COMPREHENSION

One mole of an ideal monatomic gas undergoes a linear process from A to B, in which its pressure P and its volume V change as shown in figure

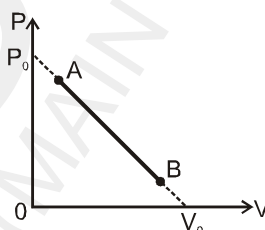

8. The absolute temperature T versus volume V for the given process is

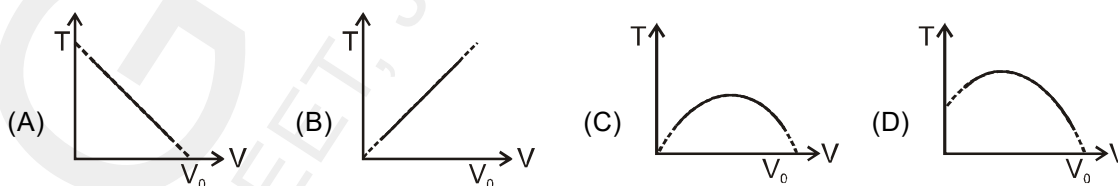

9. The maximum temperature of the gas during this process is

(A) $\frac{P_0 V_0}{2R}$ (B) $\frac{P_0 V_0}{4R}$ (C) $\frac{3P_0 V_0}{4R}$ (D) $\frac{3P_0 V_0}{2R}$

10. As the volume of the gas is increased, in some range of volume the gas expands with absorbing the heat (the endothermic process); in the other range the gas emits the heat (the exothermic process). Then the volume after which if the volume of gas is further increased the given process switches from endothermic to exothermic is

(A) $\frac{2V_0}{8}$ (B) $\frac{3V_0}{8}$ (C) $\frac{5V_0}{8}$ (D) none of these

Topics : Rigid Body Dynamics, Geometrical Optics, Simple Harmonic Motion, Center of Mass

Type of Questions

Type of Questions	M.M., Min.
Single choice Objective ('-1' negative marking) Q.1 to Q.6	[3 marks, 3 min.] [18, 18]
Multiple choice objective ('-1' negative marking) Q.7	[4 marks, 4 min.] [4, 4]
Subjective Questions ('-1' negative marking) Q.8	[4 marks, 5 min.] [4, 5]
Comprehension ('-1' negative marking) Q.9 to Q.11	[3 marks, 3 min.] [9, 9]

- A car is initially at rest, 330 m away from a stationary observer. It begins to move towards the observer with an acceleration of 1.1 m/s^2 , sounding its horn continuously. 20 second later, the driver stops sounding the horn. The velocity of sound in air is 330 m/s. The observer will hear the sound of the horn for a duration of:
 (A) 20 sec (B) 21 sec (C) $62/3$ sec (D) $58/3$ sec
- A point moves in a straight line under the retardation $a v^2$, where 'a' is a positive constant and v is speed. If the initial speed is u, the distance covered in 't' seconds is :
 (A) $a u t$ (B) $\frac{1}{a} \ln(a u t)$ (C) $\frac{1}{a} \ln(1 + a u t)$ (D) $a \ln(a u t)$
- A ring of radius R lies in vertical plane. A bead of mass 'm' can move along the ring without friction. Initially the bead is at rest at the bottom most point on ring. The minimum constant horizontal speed v with which the ring must be pulled such that the bead completes the vertical circle

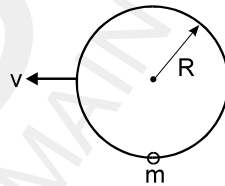

- (A) $\sqrt{3gR}$ (B) $\sqrt{4gR}$ (C) $\sqrt{5gR}$ (D) $\sqrt{5.5gR}$
- Minimum number of prisms required to make a combination which is 'Achromatic' as well as 'Direct Vision' is:
 (A) 2 (B) 3 (C) 4 (D) 11
 - As shown in figure, S is a point on a uniform disc rolling with uniform angular velocity on a fixed rough horizontal surface. The only forces acting on the disc are its weight and contact forces exerted by horizontal surface. Which graph best represents the magnitude of the acceleration of point S as a function of time

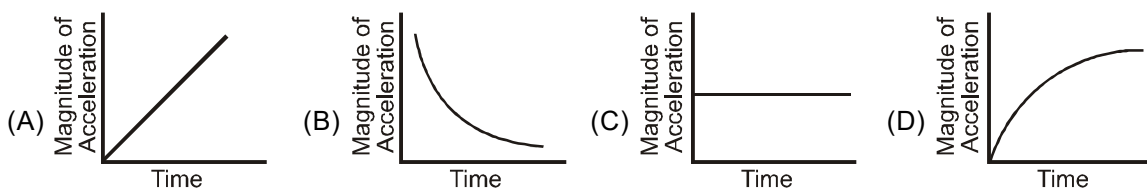
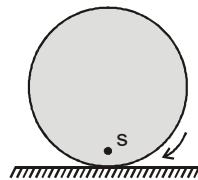

6. Consider a uniform disc of mass 'm' performing pure rolling with velocity 'v' on a fixed rough surface

- (A) Kinetic energy of upper half will be $\frac{3}{8} mv^2$
 (B) Kinetic energy of upper half will be less than $\frac{3}{8} mv^2$
 (C) Kinetic energy of upper half will be more than $\frac{3}{8} mv^2$
 (D) Kinetic energy of upper half will be more than $\frac{3}{4} mv^2$

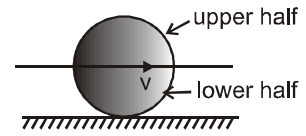

7. A block of mass $m = 1 \text{ kg}$ is placed on a smooth surface and is connected with a spring of spring constant $k = 100 \text{ N/m}$ and another end of spring is connected to a fixed wall as shown. The block is pulled by a distance $A = 0.10 \text{ m}$ from its natural length and released at $t = 0$.

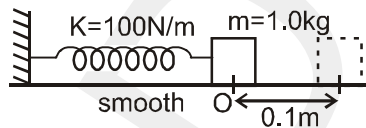

- (A) The maximum speed is after $t = \frac{\pi}{20} \text{ s}$. (B) Time taken to cover first 0.10 m , $t = \frac{\pi}{20} \text{ s}$.
 (C) Time taken to cover first 0.05 m , $t = \frac{\pi}{40} \text{ s}$. (D) Time taken to cover first 0.05 m , $t = \frac{\pi}{30} \text{ s}$.
8. A block of mass $m_1 = 2 \text{ kg}$ slides on a frictionless table with speed of 10 m/s . In front of it, another block of mass $m_2 = 5 \text{ kg}$ is moving with speed 3 m/s in the same direction. A massless spring of spring constant $k = 1120 \text{ N/m}$ is attached on the backside of m_2 as shown. Find the maximum compression of the spring in cm when the block of mass m_1 in contact with spring. (Take $g = 10 \text{ m/s}^2$)

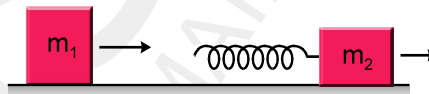

COMPREHENSION

Magnification (by a lens) of an object at distance 10 cm from it is -2 . Now a second lens is placed exactly at the same position where first was kept and first lens is removed. The magnification by this lens is -3 .

9. Find position of image formed by combination of both in contact. (relative to combination) :

- (A) $\frac{60}{9} \text{ cm}$ (B) $\frac{60}{11} \text{ cm}$ (C) $\frac{60}{13} \text{ cm}$ (D) $\frac{60}{17} \text{ cm}$

10. What is the focal length of the combination when both lenses are in contact :

- (A) $\frac{60}{17} \text{ cm}$ (B) $\frac{5}{17} \text{ cm}$ (C) $\frac{12}{7}$ (D) $\frac{13}{9} \text{ cm}$

11. When both the lenses are kept in contact at the same place, what will be the new magnification :

- (A) $\frac{-13}{5}$ (B) $\frac{-12}{7}$ (C) $\frac{-6}{11}$ (D) $\frac{-5}{7}$

Topics : Rigid Body Dynamics, Geometrical Optics, Simple Harmonic Motion, Work, Power and Energy, Electrostatics, Fluid

Type of Questions		M.M., Min.
Single choice Objective ('-1' negative marking) Q.1 to Q.4	(3 marks, 3 min.)	[12, 12]
Multiple choice objective ('-1' negative marking) Q.5 to Q.6	(4 marks, 4 min.)	[8, 8]
Subjective Questions ('-1' negative marking) Q.7 to Q.8	(4 marks, 5 min.)	[8, 10]
Comprehension ('-1' negative marking) Q.9 to Q.10	(3 marks, 3 min.)	[6, 6]

1. A circular platform is mounted on a frictionless vertical axle. Its radius $R = 2\text{m}$ and its moment of inertia about the axle is 200 kgm^2 . It is initially at rest. A 50 kg man stands on the edge of the platform and begins to walk along the edge at the speed of 1ms^{-1} relative to the ground. Time taken by the man to complete one revolution with respect to disc is :

- (A) πs (B) $\frac{3\pi}{2}\text{s}$ (C) $2\pi\text{s}$ (D) $\frac{\pi}{2}\text{s}$

2. For the angle of minimum deviation of a prism to be equal to its refracting angle, the prism must be made of a material whose refractive index :

- (A) lies between $\sqrt{2}$ and 1 (B) lies between 2 and $\sqrt{2}$
 (C) is less than 1 (D) is greater than 2

3. The potential energy of a particle executing SHM changes from maximum to minimum in 5 s. Then the time period of SHM is :

- (A) 5 s (B) 10 s (C) 15 s (D) 20 s

4. A force $\vec{F} = (3\hat{i} + 4\hat{j})\text{N}$ acts on a 2 kg movable object that moves from an initial position $\vec{d}_i = (-3\hat{i} - 2\hat{j})\text{m}$ to a final position $\vec{d}_f = (5\hat{i} + 4\hat{j})\text{m}$ in 6 s. The average power delivered by the force during the interval is equal to :

- (A) 8 watt (B) $\frac{50}{6}$ watt (C) 15 watt (D) $\frac{50}{3}$ watt.

5. Two blocks A (5kg) and B (2kg) attached to the ends of a spring constant 1120N/m are placed on a smooth horizontal plane with the spring undeformed. Simultaneously velocities of 3m/s and 10m/s along the line of the spring in the same direction are imparted to A and B then

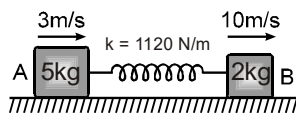

- (A) when the extension of the spring is maximum the velocities of A and B are zero.
 (B) the maximum extension of the spring is 25cm .
 (C) the first maximum compression occurs $\frac{3\pi}{56}$ seconds after start.
 (D) maximum extension and maximum compression occur alternately.

6. Two free point charges $+q$ and $+4q$ are placed a distance x apart. A third charge is so placed that all the three charges are in equilibrium. Then

- (A) unknown charge is $-4q/9$
 (B) unknown charge is $-9q/4$
 (C) It should be at $(x/3)$ from smaller charge between them
 (D) It should be placed at $(2x/3)$ from smaller charge between them.

7. A fixed container of height 'H' with large cross-sectional area 'A' is completely filled with water. Two small orifice of cross-sectional area 'a' are made, one at the bottom and the other on the vertical side of the container at a distance H/2 from the top of the container. Find the time taken by the water level to reach a height of H/2 from the bottom of the container.
8. A standing wave pattern of maximum amplitude 2mm is obtained in a string whose shape at $t = 0$ is represented in the graph. If the speed of the travelling wave in the string is 5 cm/s then find the component waves.

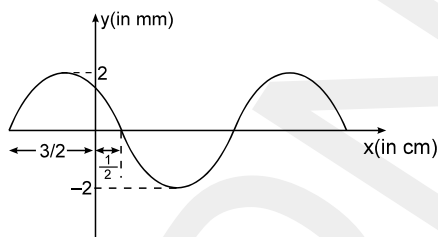

COMPREHENSION

Consider the situation in figure. The bottom of the pot is a reflecting plane mirror, S is a small fish and T is a human eye. Refractive index of water is $4/3$.

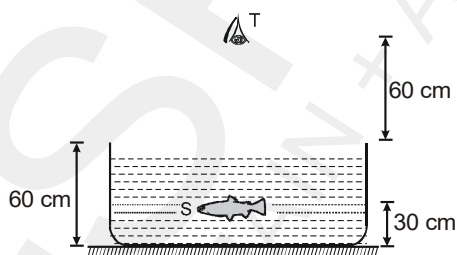

9. At what distance from itself will the fish see the image of the eye in upward direction?
 (A) 35 cm (B) 45 cm (C) 55 cm (D) 110 cm
10. At what distance from itself will the fish see the image of the eye in downward direction?
 (A) 90 cm (B) 110 cm (C) 170 cm (D) 180 cm

Topics : Electrostatics, Surface Tension, Friction, Simple Harmonic Motion, Thermal Expansion, Work, Power and Energy , Rigid Body Dynamics , Geometrical Optics

Type of Questions		M.M., Min.
Single choice Objective ('-1' negative marking) Q.1 to Q.3	(3 marks, 3 min.)	[9, 9]
Multiple choice objective ('-1' negative marking) Q.4 to Q.5	(4 marks, 4 min.)	[8, 8]
Subjective Questions ('-1' negative marking) Q.6 to Q.7	(4 marks, 5 min.)	[8, 10]
Comprehension ('-1' negative marking) Q.8 to Q.10	(3 marks, 3 min.)	[9, 9]

1. A point charge + Q is placed at the centroid of an equilateral triangle. When a second charge + Q is placed at a vertex of the triangle, the magnitude of the electrostatic force on the central charge is 8 N. The magnitude of the net force on the central charge when a third charge + Q is placed at another vertex of the triangle is:

- (A) zero (B) 4 N (C) $4\sqrt{2}$ N (D) 8 N

2. The figure shows a soap film in which a closed elastic thread is lying. The film inside the thread is pricked. Now the sliding wire is moved out so that the surface area increases. The radius of the circle formed by elastic thread will

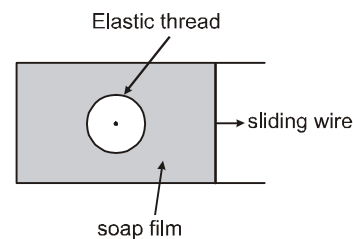

- (A) increase (B) decrease
 (C) remain same (D) data insufficient

3. A block of mass M rests on a rough horizontal surface. The co-efficient of friction between the block and the surface is μ . A force $F = Mg$ acting at angle θ with the vertical side of the block pulls it. In which of the following cases, the block can be pulled along the surface?

- (A) $\tan \theta \geq \mu$ (B) $\cot \theta \geq \mu$ (C) $\cot (\theta/2) \geq \mu$ (D) none

4. A particle is executing SHM between points $-X_m$ and X_m , as shown in figure-I. The velocity $V(t)$ of the particle is partially graphed and shown in figure-II. Two points A and B corresponding to time t_1 and time t_2 respectively are marked on the $V(t)$ curve.

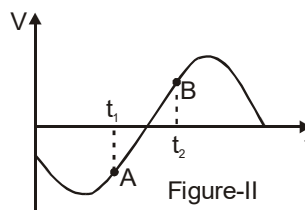
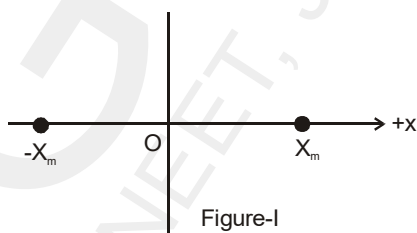

- (A) At time t_1 , it is going towards X_m .
 (B) At time t_1 , its speed is decreasing.
 (C) At time t_2 , its position lies in between $-X_m$ and O.
 (D) The phase difference $\Delta\phi$ between points A and B must be expressed as $90^\circ < \Delta\phi < 180^\circ$.

5. When the temperature of a copper coin is raised by 80°C , its diameter increases by 0.2%,
 (A) percentage rise in the area of a face is 0.4%
 (B) percentage rise in the thickness is 0.4%
 (C) percentage rise in the volume is 0.6%
 (D) coefficient of linear expansion of copper is $0.25 \times 10^{-4} / ^\circ\text{C}$.

6. Starting at rest, a 5 kg object is acted upon by only one force as indicated in figure. Find the total work done by the force.

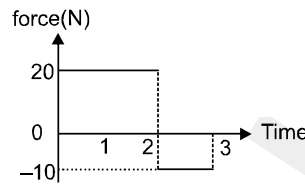

7. A 2 kg uniform cylinder is placed on a plank of mass 4 kg which in turn rests on a smooth horizontal plane. A constant horizontal force of 20 N is applied on the plank. If no slipping occurs between cylinder and plank obtain the acceleration of the cylinder and the plank.

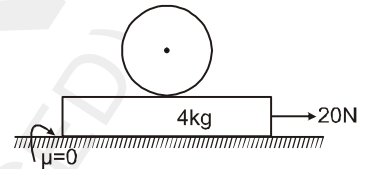

COMPREHENSION

There is a slab of refractive index n_2 placed as shown. Medium on two side are n_1 and n_3 . Width of slab is d_2 . An object is placed at distance d_1 from surface AB and observer is at distance d_3 from surface CD. Given $n_1 = \text{air}$ [ref. index = 1] and n_2 is glass [ref. index = $3/2$], $d_1 = 12 \text{ cm}$ and $d_2 = 9 \text{ cm}$, $d_3 = 4 \text{ cm}$.

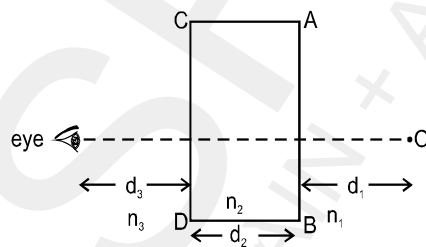

8. If object starts to move with speed of 12cm/sec towards the slab then find the speed of image as seen by observer [given $n_3 = \text{air}$ = (ref. index = 1)]
 (A) 8 cm/sec (B) 180 cm/sec (C) 12 cm/sec (D) none of these
9. If $n_3 = \frac{4}{3}$ then distance of image of object seen by observer is :
 (A) 25 cm (B) 30 cm (C) 28 cm (D) none of these
10. If $n_3 = \frac{4}{3}$ and object start to move towards the slab with speed of 12 cm/sec then speed of image is :
 (A) 16 cm/sec (B) 9 cm/sec (C) 12 cm/sec (D) none of these

Topics : Electrostatics, Fluid, Circular Motion, Work, Power and Energy, Sound Wave, String Wave, Geometrical Optics

Type of Questions

Single choice Objective ('-1' negative marking) Q.1 to Q.5	(3 marks, 3 min.)	M.M., Min. [15, 15]
Multiple choice objective ('-1' negative marking) Q.6	(4 marks, 4 min.)	[4, 4]
Subjective Questions ('-1' negative marking) Q.7	(4 marks, 5 min.)	[4, 5]
Comprehension ('-1' negative marking) Q.8 to Q.10	(3 marks, 3 min.)	[9, 9]

- Four positive charges ($2\sqrt{2}-1$) Q are arranged at corner of a square. Another charge q is placed at the centre of the square. Resultant force acting on each corner is zero if q is
 (A) $-7Q/4$ (B) $-4Q/7$ (C) $-Q$ (D) None
- A vessel contains oil (density = 0.8 gm/cm^3) over mercury (density = 13.6 gm/cm^3). A uniform sphere floats with half its volume immersed in mercury and the other half in oil. The density of the material of sphere in gm/cm^3 is:
 (A) 3.3 (B) 6.4 (C) 7.2 (D) 12.8
- A small coin of mass 40 g is placed on the horizontal surface of a rotating disc. The disc starts from rest and is given a constant angular acceleration $\alpha = 2 \text{ rad/s}^2$. The coefficient of static friction between the coin and the disc is $\mu_s = 3/4$ and coefficient of kinetic friction is $\mu_k = 0.5$. The coin is placed at a distance $r = 1 \text{ m}$ from the centre of the disc. The magnitude of the resultant force on the coin exerted by the disc just before it starts slipping on the disc is : (Take $g = 10 \text{ m/s}^2$)
 (A) 0.2 N (B) 0.3 N (C) 0.4 N (D) 0.5 N
- A block of mass 1 kg slides down a curved track that is one quadrant of a circle of radius 1m. Its speed at the bottom is 2 m/s. The work done by frictional force is : ($g = 10 \text{ m/s}^2$)

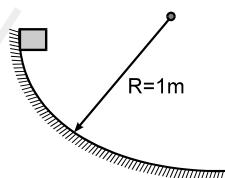
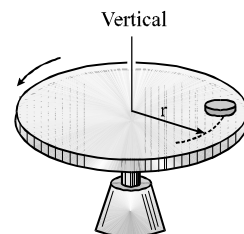

- (A) 8 J (B) -8 J
 (C) 4 J (D) -4 J

5. Which of the following is/ are correct.

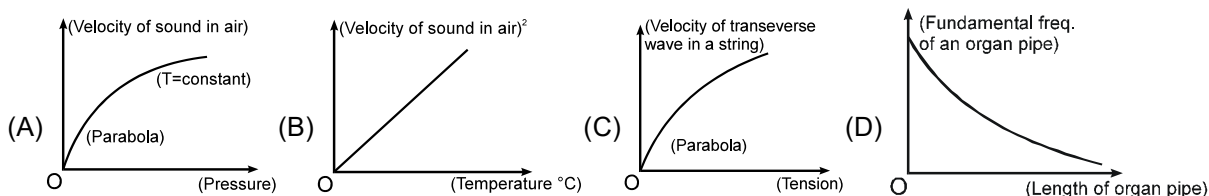

6. An electron is placed just in the middle between two long fixed line charges of charge density $+\lambda$ each. The wires are in the xy plane (Do not consider gravity)
- (A) The equilibrium of the electron will be unstable along x -direction
 (B) The equilibrium of the electron will be stable along y -direction
 (C) The equilibrium of the electron will be neutral along y -direction
 (D) The equilibrium of the electron will be stable along z -direction

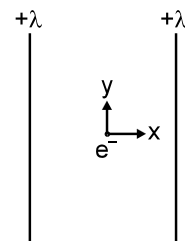

7. The ratio of the intensities of the mechanical waves propagating in the same medium $Y_1 = 10 \sin(\omega t - kx)$ and $Y_2 = 5 [\sin(\omega t - kx) + \sqrt{3} \cos(kx - \omega t)]$ is

COMPREHENSION

There is an insect inside a cabin eying towards a thick glass plate P_1 . Insect sees the images of light source across the glass plate P_1 outside the cabin. Cabin is made of thick glass plates of refractive index $\mu = \frac{3}{2}$ and thickness 3 cm. Insect is eying from the middle of the cabin as shown in figure. (glass plates are partially reflective and consider only paraxial rays)

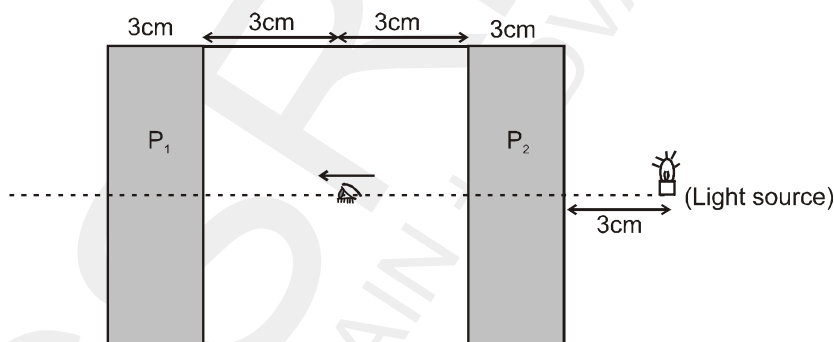

8. At what distance (from eye of insect) will the eye see first image?
 (A) 5 cm (B) 7 cm (C) 9 cm (D) 14 cm
9. At what distance (from eye of insect) will the eye see second image?
 (A) 11 cm (B) 13 cm (C) 16.5 cm (D) 18 cm
10. Number of image seen by insect ?
 (A) 2 (B) 4 (C) 8 (D) ∞

Topic : Rigid Body Dynamics, String Wave, Kinetic Theory of Gases, Thermal Expansion, Simple Harmonic Motion, Electrostatics

Type of Questions

		M.M., Min.
Single choice Objective ('-1' negative marking) Q.1 to Q.2	(3 marks, 3 min.)	[6, 6]
Multiple choice objective ('-1' negative marking) Q.3 to Q.4	(4 marks, 4 min.)	[8, 8]
Subjective Questions ('-1' negative marking) Q.5 to Q.6	(4 marks, 5 min.)	[8, 10]
Comprehension ('-1' negative marking) Q.7 to Q.9	(3 marks, 3 min.)	[9, 9]
Match the Following (no negative marking) (2 × 4)Q.10	(8 marks, 10 min.)	[8, 10]

1. A uniform cylinder of mass M lies on a fixed plane inclined at an angle θ with horizontal. A light string is tied to the cylinder's right most point, and a mass m hangs from the string, as shown. Assume that the coefficient of friction between the cylinder and the plane is sufficiently large to prevent slipping. For the cylinder to remain static, the value of mass m is-

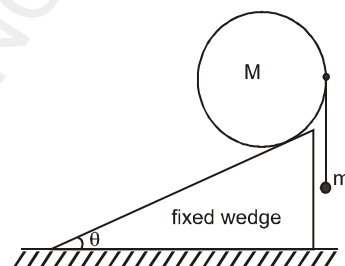

- (A) $\frac{M \cos \theta}{1 + \sin \theta}$ (B) $M \frac{\sin \theta}{1 + \sin \theta}$
 (C) $M \frac{\cos \theta}{1 - \sin \theta}$ (D) $M \frac{\sin \theta}{1 - \sin \theta}$

2. At $t = 0$, a transverse wave pulse travelling in the positive x direction with a speed of 2 m/s in a long wire is described by the function $y = \frac{6}{x^2}$, given that $x \neq 0$. Transverse velocity of a particle at $x = 2 \text{ m}$ and $t = 2$ seconds is :
- (A) 3 m/s (B) -3 m/s (C) 8 m/s (D) -8 m/s

3. Graph shows a hypothetical speed distribution for a sample of N gas particle (for $V > V_0$; $\frac{dN}{dV} = 0$, $\frac{dN}{dV}$ is rate of change of number of particles with change velocity)

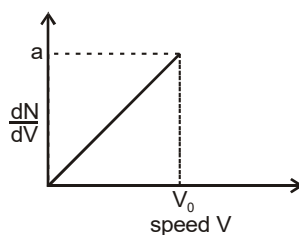

- (A) The value of aV_0 is $2N$.
 (B) The ratio V_{avg}/V_0 is equal to $2/3$.
 (C) The ratio V_{rms}/V_0 is equal to $1/\sqrt{2}$.
 (D) Three fourth of the total particle has a speed between $0.5 V_0$ and V_0 .

4. A vessel is partly filled with liquid. When the vessel is cooled to a lower temperature, the space in the vessel, unoccupied by the liquid remains constant. Then the volume of the liquid (V_L), volume of the vessel (V_v), the coefficients of cubical expansion of the material of the vessel (γ_v) and of the liquid (γ_L) are related as
- (A) $\gamma_L > \gamma_v$ (B) $\gamma_L < \gamma_v$ (C) $\gamma_v/\gamma_L = V_v/V_L$ (D) $\gamma_v/\gamma_L = V_L/V_v$

5. Two particles perform SHM with the same amplitude and same frequency about the same mean position and along the same line. If the maximum distance between them during the motion is A (A is the amplitude of either) then the phase difference between their SHM is _____.
6. Calculate the magnitude of electrostatic force on a charge placed at a vertex of a triangular pyramid (4 vertices, 4 faces), if 4 equal point charges are placed at all four vertices of pyramid of side 'a'.

COMPREHENSION

A bar of mass m is held as shown between 4 uniform discs each of mass m' and radius $r = 75$ mm. The bar has been released from rest, knowing that the normal forces exerted on the discs by vertical walls are sufficient to prevent any slipping. Answer the following questions assuming attachments are massless and fixed to the bar. (Acceleration due to gravity is g)

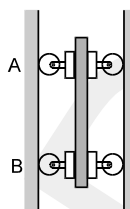

7. If $m = 5$ kg and $m' = 2$ kg, then acceleration of the bar is
 (A) g (B) $13g/7$ (C) $13g/17$ (D) $\frac{g}{17}$
8. If the mass m' of the discs is negligible, then acceleration of the bar is
 (A) g (B) $2g/3$ (C) $13g/17$ (D) $\frac{g}{17}$
9. If the mass m of the bar is negligible, then acceleration of the bar is
 (A) g (B) $2g/3$ (C) $13g/17$ (D) $\frac{g}{17}$
10. Assume only electrostatic interaction forces :

Column – I

- (A) Three charges are kept along a straight line
 (B) Three charges are kept at the vertices of an equilateral triangle
 (C) Three charges are kept at the three vertices of a square, and a fourth charge is kept at the point of intersection of the diagonals.
 (D) Three charges are kept at the vertices of an equilateral triangle with the fourth charge at the centroid.

Column – II

- (p) The system may be in equilibrium with proper choice of the value of charges.
 (q) The system will be in equilibrium for any value of the charges.
 (r) The system will not be in equilibrium for any choice of the value of charges.
 (s) The equilibrium is unstable.

Topics : Calorimetry & Thermal Expansion, Electrostatics, Work, Power and Energy, Rigid Body Dynamics, String Wave, Geometrical Optics

Type of Questions

		M.M., Min.
Single choice Objective ('-1' negative marking) Q.1 to Q.5	(3 marks, 3 min.)	[15, 15]
Subjective Questions ('-1' negative marking) Q.6	(4 marks, 5 min.)	[4, 5]
Comprehension ('-1' negative marking) Q.7 to Q.9	(3 marks, 3 min.)	[9, 9]
Match the Following (no negative marking) (2 × 4)	(8 marks, 10 min.)	[8, 10]

1. Water of mass $m_2 = 1$ kg is contained in a copper calorimeter of mass $m_1 = 1$ kg. Their common temperature $t = 10^\circ\text{C}$. Now a piece of ice of mass $m_3 = 2$ kg and temperature is -11°C dropped into the calorimeter. Neglecting any heat loss, the final temperature of system is. [specific heat of copper = 0.1 Kcal/kg $^\circ\text{C}$, specific heat of water = 1 Kcal/kg $^\circ\text{C}$, specific heat of ice = 0.5 Kcal/kg $^\circ\text{C}$, latent heat of fusion of ice = 78.7 Kcal/kg]

- (A) 0°C (B) 4°C (C) -4°C (D) -2°C

2. Two identical spheres of same mass and specific gravity (which is the ratio of density of a substance and density of water) 2.4 have different charges of Q and $-3Q$. They are suspended from two strings of same length ℓ fixed to points at the same horizontal level, but distant ℓ from each other. When the entire set up is transferred inside a liquid of specific gravity 0.8 , it is observed that the inclination of each string in equilibrium remains unchanged. Then the dielectric constant of the liquid is

- (A) 2 (B) 3 (C) 1.5 (D) None of these

3. A block of mass 10 kg is released on a fixed wedge inside a cart which is moved with constant velocity 10 m/s towards right. Take initial velocity of block with respect to cart zero. Then work done by normal reaction (with respect to ground) on block in two seconds will be: ($g = 10$ m/s 2).

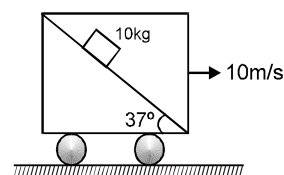

- (A) zero (B) 960 J
 (C) 1200 J (D) none of these

4. If the frequency of a wave is increased by 25% , then the change in its wavelength will be: (medium not changed)

- (A) 20% increase (B) 20% decrease (C) 25% increase (D) 25% decrease

5. The moment of inertia of a thin sheet of mass M of the given shape about the specified axis is

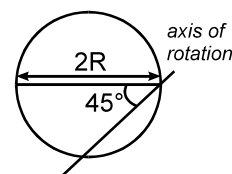

- (A) $(3/2)MR^2$ (B) $(3/4)MR^2$
 (C) $MR^2(1 + 1/\sqrt{2})$ (D) $MR^2/(2\sqrt{2})$

6. AB wire is vibrating in its fundamental mode. Wire AB is in resonance with resonance tube in which air column is also vibrating with its fundamental mode. Sound speed is 400 m/sec and linear mass density of AB wire is 10^{-4} kg/m and $g = 10$ m/sec 2 , value of mass $m = [\beta(10^{-1})]$ kg, then find value of β . Neglect the masses of wires in comparison to block's mass 'm'.

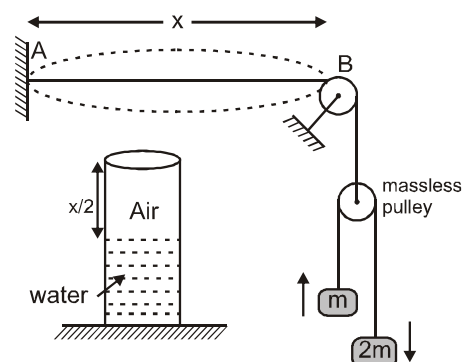

COMPREHENSION

A glass prism with a refracting angle of 60° has a refractive index 1.52 for red and 1.6 for violet light. A parallel beam of white light is incident on one face at an angle of incidence, which gives minimum deviation for red light. Find :

[Use: $\sin(50^\circ) = 0.760$; $\sin(31.6^\circ) = 0.520$; $\sin(28.4^\circ) = 0.475$; $\sin(56^\circ) = 0.832$; $\pi = 22/7$]

7. The angle of incidence at the prism is :
 (A) 30° (B) 40° (C) 50° (D) 60°
8. The angular width of the spectrum is :
 (A) 6° (B) 4.8° (C) 9.6° (D) 12°
9. The length of the spectrum if it is focussed on a screen by a lens of focal length 100 cm is :
 (A) $\frac{10\pi}{3}$ cm (B) $\frac{10\pi}{3}$ m (C) $\frac{5\pi}{3}$ cm (D) $\frac{5\pi}{3}$ m
10. The column I gives the two point charge system separated by $2a$ and the column II gives the variation of magnitude of electric field intensity at point on the x-axis. Match the situation in Column I with the results in Column II and indicate your answer by darkening appropriate bubbles in the 4×4 matrix given in the OMR.

Column – I

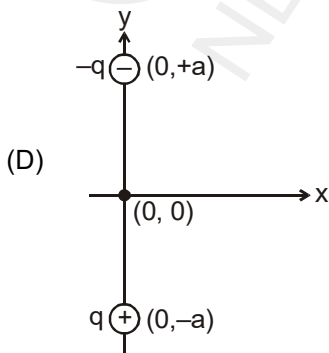
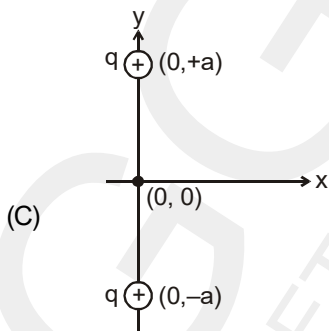
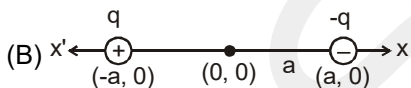
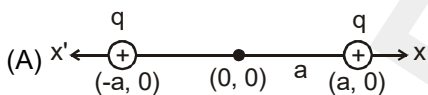

Column – II

(p) Increases as x increases
 in the interval $0 \leq x < a$

(q) Decreases as x increases
 in the interval $0 \leq x < a$

(r) Zero at $x = 0$

(s) Decreases as x increases
 in the interval $a < x < \infty$

Topics : Rigid Body Dynamics, Electrostatics, Kinematics, Sound Wave, Friction, Fluid

Type of Questions

Type of Questions	M.M., Min.
Single choice Objective ('-1' negative marking) Q.1 to Q.4	(3 marks, 3 min.) [12, 12]
Multiple choice objective ('-1' negative marking) Q.5	(4 marks, 4 min.) [4, 4]
Subjective Questions ('-1' negative marking) Q.6	(4 marks, 5 min.) [4, 5]
Comprehension ('-1' negative marking) Q.7 to Q.9	(3 marks, 3 min.) [9, 9]
Match the Following (no negative marking) (2 × 4)Q.10	(8 marks, 10 min.) [8, 10]

1. A uniform rod of mass M and length L leans against a frictionless wall, with quarter of its length hanging over a corner as shown. Friction at corner is sufficient to keep the rod at rest. Then the ratio of magnitude of normal reaction on rod by wall and the magnitude of normal reaction on rod by corner is

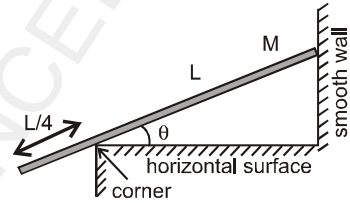

- (A) $\frac{1}{2\sin\theta}$ (B) $\frac{2}{\sin\theta}$ (C) $\frac{1}{2\cos\theta}$ (D) $\frac{2}{\cos\theta}$

2. A non-conducting semicircular disc (as shown in figure) has a uniform surface charge density σ . The ratio of electric field to electric potential at the centre of the disc will be :

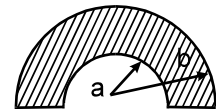

- (A) $\frac{1}{\pi} \frac{\ln b/a}{(b-a)}$ (B) $\frac{2}{\pi}$ (C) $\frac{1}{\pi} \frac{\ln(b/a)^2}{(b-a)}$ (D) $\frac{\pi(b-a)}{2\ln(b/a)}$

3. Two particles P and Q start their journey simultaneously from point A. P moves along a smooth horizontal wire AB. Q moves along a curved smooth track. Q has sufficient velocity at A to reach B always remaining in contact with the curved track. At A, the horizontal component of velocity of Q is same as the velocity of P along the wire. The plane of motion is vertical. If t_1, t_2 , are times taken by P and Q respectively to reach B then (Assume velocity of P is constant)

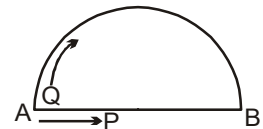

- (A) $t_1 = t_2$ (B) $t_1 > t_2$ (C) $t_1 < t_2$ (D) none of these

4. A receiver and a source of sonic oscillations of frequency 200 Hz are located on the x-axis. The receiver is fixed and the source swings harmonically along that axis with a circular frequency ω and an amplitude 50 cm. At what value of ω (in rad/sec) will the frequency band width ($f_{\max} - f_{\min}$) registered by the stationary receiver be equal to 20 Hz. [The velocity of sound is equal to 340 m/s]

- (A) 17 (B) 34 (C) 68 (D) 8.5

5. Block A is kept on block B as shown in figure. It is known that acceleration of block A is 2 m/s^2 towards right and acceleration of block B is 3 m/s^2 towards right under the effect of unknown forces. Direction of friction force acting on A by B ($\mu_{AB} = 0.3$)

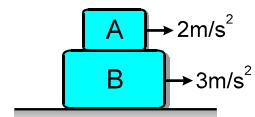

- (A) is necessarily towards right (B) may be towards right
 (C) may be towards left (D) may be zero

6. An infinitely large non-conducting plane of uniform surface charge density σ has circular aperture of certain radius carved out from it. The electric field at a point which is at a distance 'a' from the centre of the aperture (perpendicular to the

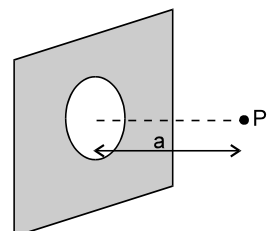

plane) is $\frac{\sigma}{2\sqrt{2}\epsilon_0}$. Find the radius of aperture :

COMPREHENSION

A tank of base area 4 m^2 is initially filled with water up to height 2 m . An object of uniform cross-section 2 m^2 and height 1 m is now suspended by wire into the tank, keeping distance between base of tank and that of object 1 m . Density of the object is 2000 kg/m^3 . Take atmospheric pressure $1 \times 10^5 \text{ N/m}^2$; $g = 10 \text{ m/s}^2$.

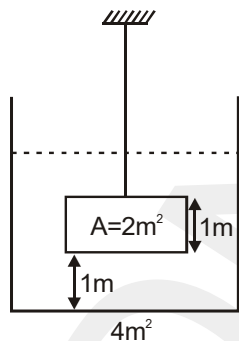

7. The downwards force exerted by the water on the top surface of the object is :
 (A) $2.0 \times 10^5 \text{ N}$ (B) $2.1 \times 10^5 \text{ N}$ (C) $2.2 \times 10^5 \text{ N}$ (D) $2.3 \times 10^5 \text{ N}$
8. The tension in the wire is :
 (A) $0.1 \times 10^5 \text{ N}$ (B) $0.2 \times 10^5 \text{ N}$ (C) $0.3 \times 10^5 \text{ N}$ (D) $0.4 \times 10^5 \text{ N}$
9. The buoyant force on the object is :
 (A) $0.1 \times 10^5 \text{ N}$ (B) $0.2 \times 10^5 \text{ N}$ (C) $0.3 \times 10^5 \text{ N}$ (D) $0.4 \times 10^5 \text{ N}$
10. In each situation of column-I a mass distribution is given and information regarding x and y-coordinate of centre of mass is given in column-II. Match the figures in column-I with corresponding information of centre of mass in column-II.

Column-I

- (A) An equilateral triangular wire frame is made using three thin uniform rods of mass per unit lengths λ , 2λ and 3λ as shown
- (B) A square frame is made using four thin uniform rods of mass per unit length lengths λ , 2λ , 3λ and 4λ as shown
- (C) A circular wire frame is made of two uniform semicircular wires of same radius and of mass per unit length λ and 2λ as shown
- (D) A circular wire frame is made of four uniform quarter circular wires of same radius and mass per unit length λ , 2λ , 3λ and 4λ as shown

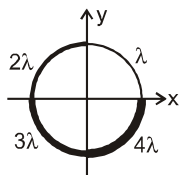
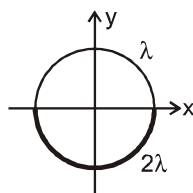
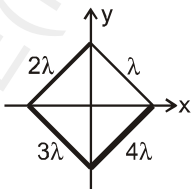
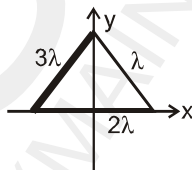

Column-II

- (p) $x_{cm} \geq 0$
- (q) $y_{cm} \geq 0$
- (r) $x_{cm} < 0$
- (s) $y_{cm} < 0$

Topics : Geometrical Optics , Kinetic Theory of Gases, Rigid Body Dynamics, String Wave, Electrostatics, Center of Mass

Type of Questions

Type of Questions	M.M., Min.
Single choice Objective ('-1' negative marking) Q.1 to Q.4	(3 marks, 3 min.) [12, 12]
Multiple choice objective ('-1' negative marking) Q.5	(4 marks, 4 min.) [4, 4]
Subjective Questions ('-1' negative marking) Q.6 to Q.7	(4 marks, 5 min.) [8, 10]
Comprehension ('-1' negative marking) Q.8 to Q.10	(3 marks, 3 min.) [9, 9]

1. An infinitely long rectangular strip is placed on principal axis of a concave mirror as shown in figure. One end of the strip coincides with centre of curvature as shown. The height of rectangular strip is very small in comparison to focal length of the mirror. Then the shape of image of strip formed by concave mirror is

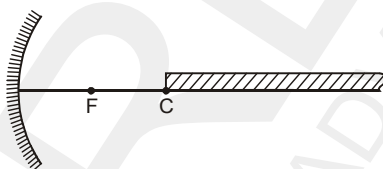

- (A) Rectangle (B) Trapezium (C) Triangle (D) Square
2. $N (< 100)$ molecules of a gas have velocities $1, 2, 3, \dots, N$ km/s respectively. Then
 (A) rms speed and average speed of molecules is same.
 (B) ratio of rms speed to average speed is $\sqrt{(2N+1)(N+1)}/6N$
 (C) ratio of rms speed to average speed is $\sqrt{(2N+1)(N+1)}/6$
 (D) ratio of rms speed to average speed of molecules is $2\sqrt{(2N+1)}/6(N+1)$
3. A horizontal plane supports a fixed vertical cylinder of radius R and a particle is attached to the cylinder by a horizontal thread AB as shown in Fig. A horizontal velocity v_0 is imparted to the particle, normal to the thread, then during subsequent motion

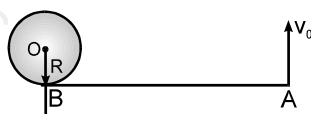

- (A) Angular momentum of particle about O remains constant
 (B) Angular momentum about B remains constant
 (C) Momentum and kinetic energy both remain constant
 (D) Kinetic energy remain constant.
4. The equation of a string wave is given by (all quantity expressed in S.I. units) $Y = 5 \sin 10\pi(t - 0.01x)$ along the x -axis. The magnitude of phase difference between the points separated by a distance of 10 m along x -axis is
 (A) $\pi/2$ (B) π (C) 2π (D) $\pi/4$.

5. Two infinite plane sheets A and B are shown in the figure. The surface charge densities on A and B are $(2/\pi) \times 10^{-9} \text{ C/m}^2$ and $(-1/\pi) \times 10^{-9} \text{ C/m}^2$ respectively. C, D, E are three points where electric fields (in N/C) are E_C , E_D and E_E respectively.

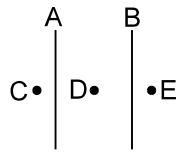

- (A) $E_C = 18$, towards right
 (B) $E_D = 54$, towards right
 (C) $E_D = 18$, towards right
 (D) $E_E = 18$, towards right
6. A sinusoidal wave propagates along a string. In figure (a) and (b) 'y' represents displacement of particle from the mean position. 'x' and 't' have usual meanings. Find:

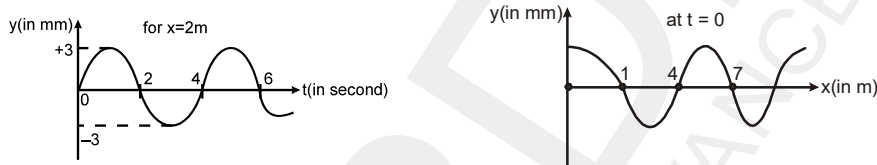

- (a) wavelength, frequency and speed of the wave.
 (b) maximum velocity and maximum acceleration of the particles
 (c) the magnitude of slope of the string at $x = 2$ at $t = 4$ sec.
7. A point charge Q is located at centre of a fixed thin ring of radius R with uniformly distributed charge-Q. The magnitude of the electric field strength at the point lying on the axis of the ring at a distance x from the centre is ($x \gg R$) _____.

COMPREHENSION

Figure shows an irregular wedge of mass m placed on a smooth horizontal surface. Horizontal part BC is rough. The other part of the wedge is smooth.

8. What minimum velocity should be imparted to a small block of same mass m so that it may reach point B :

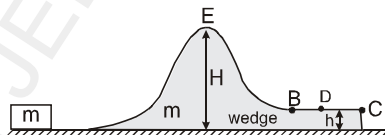

- (A) $2\sqrt{gH}$ (B) $\sqrt{2gH}$ (C) $2\sqrt{g(H-h)}$ (D) \sqrt{gh}
9. The magnitude of velocity of wedge when the block comes to rest (w.r.t. wedge) on part BC is :
- (A) \sqrt{gH} (B) $\sqrt{g(H-h)}$ (C) $2\sqrt{gH}$ (D) none of these
10. If the coefficient of friction between the block and wedge is μ , and the block comes to rest with respect to wedge at a point D on the rough surface then BD will be
- (A) $\frac{H}{\mu}$ (B) $\frac{H-h}{\mu}$ (C) $\frac{h}{\mu}$ (D) none of these



GGSRDN

Educational Services Private Limited

9th, 10th, NEET, JEE(Main/Advanced)

अभ्यास ही सबसे बड़ा गुरु है।

CLASS : XII (PHYSICS)

D P P P

DAILY PRACTICE PROBLEM

DPP-11 TO 21

Solutions

- DPP 11 : Geometrical Optics, Fluid, Work, Power and Energy, Center of Mass, Circular Motion, Heat and Thermodynamics, Rigid Body Dynamics
- DPP 12 : Geometrical Optics., Rectilinear Motion, String Wave, Projectile Motion, Rigid Body Dynamics, Heat and Thermodynamics
- DPP 13 : Rigid Body Dynamics, Geometrical Optics, Simple Harmonic Motion, Center of Mass
- DPP 14 : Rigid Body Dynamics, Geometrical Optics, Simple Harmonic Motion, Work, Power and Energy, Electrostatics, Fluid
- DPP 15 : Topics : Electrostatics, Surface Tension, Friction, Simple Harmonic Motion, Thermal Expansion, Work, Power and Energy, Rigid Body Dynamics, Geometrical Optics
- DPP 16 : Electrostatics, Fluid, Circular Motion, Work, Power and Energy, Sound Wave, String Wave, Geometrical Optics
- DPP 17 : Rigid Body Dynamics, String Wave, Kinetic Theory of Gases, Thermal Expansion, Simple Harmonic Motion, Electrostatics
- DPP 18 : Calorimetry & Thermal Expansion, Electrostatics, Work, Power and Energy, Rigid Body Dynamics, String Wave, Geometrical Optics
- DPP 19 : Rigid Body Dynamics, Electrostatics, Kinematics, Sound Wave, Friction, Fluid
- DPP 20 : Geometrical Optics, Kinetic Theory of Gases, Rigid Body Dynamics, String Wave, Electrostatics, Center of Mass

Answers Key

DPP NO. - 11

1. (D) 2. (C) 3. (D) 4. (A) 5. (A)
6. (B), (C) 7. (A) 8. $R = 75 \text{ cm.}$ 9. (B)
10. (C)

DPP NO. - 12

1. (A) 2. (B) 3. (A) 4. (D)
5. $h = \frac{125}{3} \text{ m}$ above point of projection
6. $2 F_2 b/ma$ 7. 8 cm 8. (C)
9. (B) 10. (C)

DPP NO. - 13

1. (D) 2. (C) 3. (B) 4. (A)
5. (C) 6. (C) 7. (A), (B), (D)
8. 25 cm. 9. (B) 10. (A) 11. (C)

DPP NO. - 14

1. (C) 2. (B) 3. (D) 4. (A)
5. (B), (C), (D) 6. (A), (C)
7. $t = \frac{2A}{3a} (\sqrt{2} - 1) \sqrt{\frac{H}{g}}$
8. $\sin \left(\frac{\pi}{2}x + \frac{3\pi}{4} + \frac{5\pi}{2}t \right) + \sin \left(\frac{\pi}{2}x + \frac{3\pi}{4} - \frac{5\pi}{2}t \right)$
9. (D) 10. (C)

DPP NO. - 15

1. (D) 2. (C) 3. (C)
4. (B), (C) 5. (A), (C), (D) 6. 90 J
7. $a_1 = \frac{10}{7} \text{ m/s}^2, a_2 = \frac{30}{7} \text{ m/s}^2$
8. (C) 9. (C) 10. (A)

DPP NO. - 16

1. (A) 2. (C) 3. (D) 4. (B) 5. (C)
6. (A), (C), (D) 7. 1:1 8. (D) 9. (D)
10. (D)

DPP NO. - 17

1. (D) 2. (B) 3. (A), (B), (C), (D)
4. (A), (D) 5. $\phi = \pi/3$
6. $\frac{\sqrt{6} q^2}{4\pi \epsilon_0 a^2}$ 7. (C) 8. (A)
9. (B) 10. (A) p, s; (B) r; (C) r; (D) p, s

DPP NO. - 18

1. (A) 2. (C) 3. (B) 4. (B)
5. (B) 6. 6 7. (C) 8. (A)
9. (A) 10. (A) \rightarrow (p, r, s), (B) \rightarrow (p, s),
(C) \rightarrow (r, s), (D) \rightarrow (q, s)

DPP NO. - 19

1. (A) 2. (C) 3. (B) 4. (B)
5. (B), (C), (D) 6. a 7. (B)
8. (B) 9. (B)
10. (A) q, r (B) p, s (C) p, s (D) p, s

DPP NO. - 20

1. (C) 2. (D) 3. (D)
4. (B) 5. (B), (D)
6. (a) 6m, 0.25 Hz, 1.5m/s
(b) $1.5\pi \text{ mm/s}, 0.75\pi^2 \text{ mm/s}^2$ (c) $\pi \times 10^{-3}$
7. $\frac{3QR^2}{8\pi \epsilon_0 X^4}$
8. (A) 9. (A) 10. (B)

HINTS AND SOLUTIONS

DPP NO. - 11

- When object moves normal to the mirror, image velocity will be opposite to it. When object moves parallel to the mirror, image velocity will be in the same direction.
- As the object moves from infinity to centre of curvature, the distance between object and image reduces from infinity to zero. As the object moves from centre of curvature to focus, the distance between object and image increases from zero to infinity. As the object moves from focus to pole, the distance between object and its image reduces from infinity to zero. Hence the distance between object and its image shall be 40 cm three times.

3. Force on bottom surface = $\rho g H \times A$

4. At any time

$$\vec{v} = [(u \cos \theta) \hat{i} + (u \sin \theta - gt) \hat{j}]$$

$$P = \vec{F} \cdot \vec{v} = (-mg\hat{j}) \cdot [u \cos \theta \hat{i} + (u \sin \theta - gt) \hat{j}]$$

$$= mg^2 t - mgu \sin \theta$$

Hence, power varies linearly with time.

6.

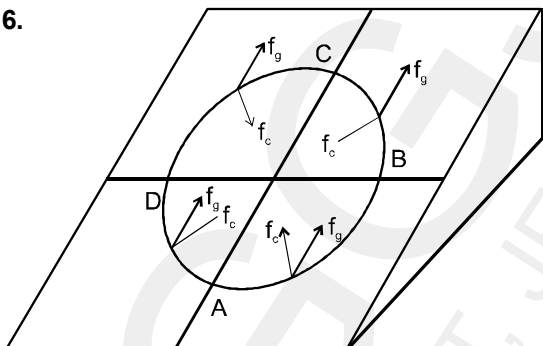

Friction force acting on car will be resultant of the components shown in the diagram.

f_g and f_c are components of friction force that balance gravitational pull and provides centripetal force respectively

The resultant of f_g and f_c can be horizontal only for a point at BC and CD and not for AB and BD

7. As work done in state (II) is more than in state (I)

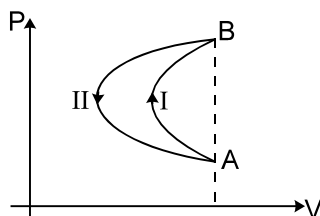

8. Image due to plane mirror will form at a distance of 20 cm left of the mirror. Since image formed by two mirrors lie adjacent to each other.

For convex mirror, image position is 15 cm towards left.

$$u = -25 \text{ cm}$$

$$v = +15 \text{ cm}$$

$$\text{using } \frac{1}{v} + \frac{1}{u} = \frac{1}{f} = \frac{2}{R}$$

$$\frac{1}{15} - \frac{1}{25} = \frac{2}{R}$$

$$R = 75 \text{ cm.}$$

Ans. R = 75 cm.

9-10. Suppose velocity of ring

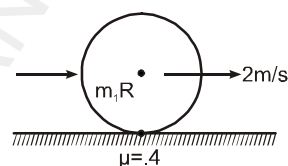

When it starts pure rolling is v . Angular momentum can be constant about point of contact as there is no external torque acting about it. Thus

$$m \cdot 2R = m \cdot R^2 \left(\frac{v}{R} \right) + mvR$$

$$\Rightarrow v = 1 \text{ m/s}$$

$$\text{using } v = u + at$$

$$1 = 2 + (-4)t$$

$$\Rightarrow t = 1/4 \text{ sec.}$$

[Ans.: 1 m/s, 1/4 sec.]

DPP NO. - 12

1.

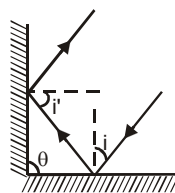

$$\delta = \delta_1 + \delta_2 = (180 - 2i) + (180 - 2i')$$

$$= 360 - 2(i + i')$$

$$\delta = 360^\circ - 2\theta$$

$$\delta = 360^\circ - 2(90^\circ) = 180^\circ.$$

2. The only possibility is by reflection from concave mirror as shown.

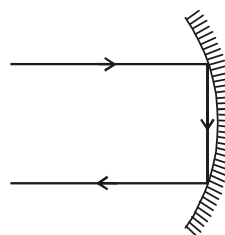

3. (A) Area under P-x graph = $\int p dx = \int \left(m \frac{dv}{dt} \right) v dx$

$$= \int_1^v m v^2 dV = \left[\frac{m v^3}{3} \right]_1^v = \frac{10}{7 \times 3} (v^3 - 1)$$

from graph ; area = $\frac{1}{2} (2 + 4) \times 10 = 30$

$$\therefore \frac{10}{7 \times 3} (v^3 - 1) = 30$$

$$\therefore v = 4 \text{ m/s}$$

ALITER :

from graph
 $P = 0.2 x + 2$

or $m v \frac{dv}{dx} = 0.2 x + 2$

or $m v^2 dv = (0.2 x + 2) dx$
 Now integrate both sides,

$$\int_1^v m v^2 dv = \int_1^{10} (0.2 x + 2) dx$$

$$\Rightarrow v = 4 \text{ m/s.}$$

4. Resultant Displacement

$y = y_1 + y_2$
 for y to be zero
 $y = 0$

$$(2x - 3t)^2 = (2x + 3t - 6)^2$$

on solving $(x - \frac{3}{2})(t - 1) = 0$

Therefore,

at $x = \frac{3}{2}$, resultant displacement is zero for all values of t.

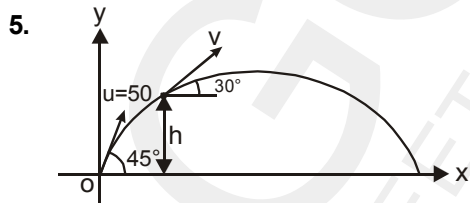

$h =$ height of the point where velocity makes 30° with horizontal.

As the horizontal component of velocity remain same
 $50 \cos 45^\circ = v \cos 30^\circ$

$$v = 50 \sqrt{\frac{2}{3}}$$

Now by equation
 $v^2 = u^2 + 2a_y y$

$$\left(50 \times \sqrt{\frac{2}{3}} \right)^2 = 50^2 - 2gh$$

$$\Rightarrow 2gh = 50^2 - 50^2 \times \frac{2}{3}$$

$$\Rightarrow 2gh = \frac{1}{3} \times 50^2$$

$$\Rightarrow h = \frac{2500}{60} = \frac{125}{3}$$

$$h = \frac{125}{3} \text{ m above point of projection}$$

6. As Rod is in linear motion only (there's no rotation of the rod), Net torque about COM must be zero. Hence

$$F_1 \cdot \frac{\ell}{2} - F_2 \left(\frac{\ell}{2} - b \right) = 0 \quad \dots\dots(1)$$

also for linear motion.

$$F_2 - F_1 = ma \quad \dots\dots(2)$$

solving (1) and (2)

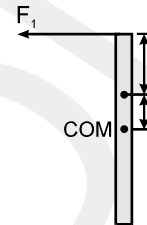

$$\ell = \frac{2F_2 b}{ma} \quad \text{Ans.}$$

7. for $M_1 : \rightarrow u = -30, f = -20$

$$\therefore \frac{1}{v} + \frac{1}{-30} = \frac{1}{-20} \Rightarrow v = -60 \text{ cm}$$

$$m_1 = -\frac{v}{u} = -\frac{-60}{-30} = -2.$$

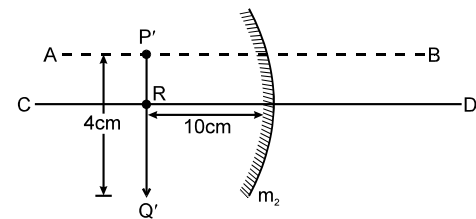

The image By M_1 is $P'Q'$

for $M_2 : u = +10, f = +20$

$$\therefore \frac{1}{v} + \frac{1}{10} = \frac{1}{20} \Rightarrow v = -20 \text{ cm}$$

$$m_2 = -\frac{-20}{10} = +2$$

now the size of final image is = **8 cm. Ans.**

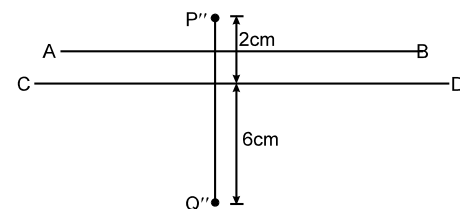

distance of P'' from AB = 1 cm. Ans.

distance of Q'' from AB = 7 cm. Ans.

8, 9, 10. From The P–V graph, the relation between P

and V is $P = -\frac{P_0}{V_0}V + P_0 \dots (1)$

Also the ideal gas state equation for one mole is $PV = RT \dots (2)$

From equation (1) and (2) is $T = \frac{P_0}{R}V \left(1 - \frac{V}{V_0}\right)$

Hence the graph of T vs. V is a parabola given by

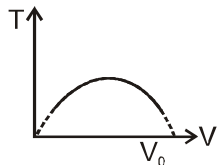

Obviously T is maximum at $V = \frac{V_0}{2}$. There

maximum value of T is $\frac{P_0 V_0}{4R}$

$Q = \Delta U + W$

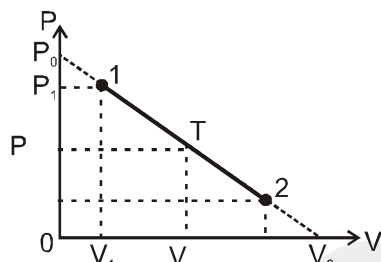

where ΔU is the change in the internal energy of the gas; and W is work, done by the gas. For one mole of the monatomic ideal gas $\Delta U = 3/2R \Delta T$. Work equals the area under the graph P vs. V. Therefore, for the process from the initial state with $P_1 V_1 = 3/2 RT_1$ to the state with P, V, T the heat given to system is

$$Q = (3/2) R (T - T_1) + (1/2) (P + P_1) (V - V_1)$$

$$= \frac{3}{2} (PV - P_1 V_1) + \frac{1}{2} (PV + P_1 V + P V_1 - P_1 V_1) \dots (3)$$

$$= 2PV + \frac{1}{2} P_1 V - \frac{1}{2} P V_1 - 2P_1 V_1$$

from equation 1 and 3 we get

$$Q = 2\frac{P_0}{V_0} V^2 + \frac{5}{2} P_0 V - 2P_0 V_1 \left(\frac{5}{4} - \frac{V_1}{V_0}\right)$$

The process switches from endothermic to exothermic

as $\frac{dQ}{dV}$ changes from positive to negative, that is

at $\frac{dQ}{dV} = 0$. Solving we get $V = \frac{5}{8} V_0$

DPP NO. - 13

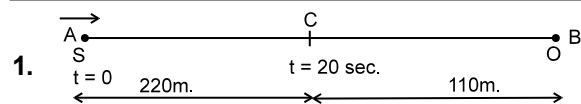

In 20 seconds, distance travelled by the Source is :

$$S = \frac{1}{2} (1.1) (20)^2 = 220 \text{ m.}$$

Let, $t = 0$ be the starting time.

The sound wave started at $t = 0$ from 'A' reaches

the observer at 'B' after $\left(\frac{330}{330}\right) = 1 \text{ sec.}$ ie. observer

started hearing the sound at $t = 1 \text{ sec.}$ At $t = 20 \text{ sec.}$ the source reaches at 'C' 220 m from 'A'.

The last sound wave starting from 'C' reaches 'B'

after $\left(\frac{110}{330}\right) = \frac{1}{3} \text{ sec} < 1 \text{ sec.}$

Hence, the observer do not hear the sound for whole 20 sec.

but for:

$$T = \left(19 + \frac{1}{3}\right) \text{ sec} = \frac{58}{3} \text{ sec.}$$

2. The retardation is given by

$$\frac{dv}{dt} = -av^2$$

integrating between proper limits

$$\Rightarrow -\int_u^v \frac{dv}{v^2} = \int_0^t a dt$$

or $\frac{1}{v} = at + \frac{1}{u}$

$$\Rightarrow \frac{dt}{dx} = at + \frac{1}{u}$$

$$\Rightarrow dx = \frac{u dt}{1 + aut}$$

integrating between proper limits

$$\Rightarrow \int_0^s dx = \int_0^t \frac{u dt}{1 + aut}$$

$$\Rightarrow S = \frac{1}{a} \ln(1 + aut)$$

3. In the frame of ring (inertial w.r.t. earth), the initial velocity of the bead is v at the lowest position.

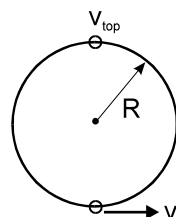

The condition for bead to complete the vertical circle is, its speed at top position

$$v_{\text{top}} \geq 0$$

From conservation of energy

$$\frac{1}{2} m v_{\text{top}}^2 + mg(2R) = \frac{1}{2} m v^2$$

or $v = \sqrt{4gR}$

5. Since angular velocity is constant, acceleration of centre of mass of disc is zero. Hence the magnitude of acceleration of point S is $\omega^2 x$ where ω is angular speed of disc and x is the distance of S from centre. Therefore the graph is

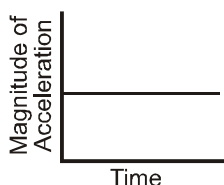

6. T.K.E. of disc [M.Bank_Rotation_7.120]

$$= \frac{1}{2} m v^2 + \frac{1}{2} I \omega^2$$

$$= \frac{1}{2} m v^2 + \frac{1}{2} \times \frac{m r^2}{2} \times \left(\frac{v}{r}\right)^2$$

$$= \frac{3}{4} m v^2$$

Velocity of particles of upper half is more than that of lower half hence kinetic energy of upper half will be

more than $\frac{3}{8} m v^2$.

7. $\omega = \sqrt{\frac{K}{m}} = 10 \text{ rad/s}$

$$T = \frac{2\pi}{\omega} = \frac{2\pi}{10} \text{ s}$$

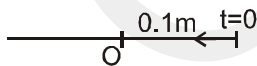

Maximum speed will be at the natural length of

the spring at $T/4 = \frac{2\pi}{10 \times 4} = \frac{\pi}{20} \text{ s}$.

Time taken to cover 0.1 m is $\frac{T}{4} = \frac{\pi}{20} \text{ s}$

Time taken to cover $\frac{1}{2} \times 0.1 \text{ m}$ is

$$\frac{T}{4} \times \frac{2}{3} = \frac{2\pi}{10 \times 4} \times \frac{2}{3} = \frac{\pi}{30} \text{ s}$$

8. Compression is maximum when both blocks move with same velocity V.

By cons. of momentum

$$V = \frac{m_1 v_1 + m_2 v_2}{m_1 + m_2} = 5 \text{ m/s}$$

The change in K.E. = $k_f - k_i = -35 \text{ J}$

This is stored as spring PE

Therefore $\frac{1}{2} k x^2 = \Delta K \Rightarrow x = \sqrt{\frac{2\Delta K}{k}}$

on solving $x = 0.25 \text{ m} = 25 \text{ cm}$.

9 to 11

Magnification is negative, therefore lens is convex. $v = m.u$

u is negative and v is positive u

$$\frac{1}{20} + \frac{1}{10} = \frac{1}{f_1} \dots (i)$$

$$\frac{1}{30} + \frac{1}{10} = \frac{1}{f_2} \dots (ii)$$

$$\frac{1}{v} + \frac{1}{10} = \frac{1}{f_1} + \frac{1}{f_2} = \frac{1}{f} \dots (iii)$$

For combination

$$m = \frac{v}{u} = \frac{60/11}{-10} = \frac{-6}{11}$$

DPP NO. - 14

1. using angular momentum conservation

$$L_i = 0$$

$$L_f = m v R - I \omega$$

$$m v R = I \omega$$

$$\omega = \left(\frac{1}{2}\right) \quad (v + \omega R)t = 2\pi R$$

$$\left(1 + \frac{1}{2} \times 2\right) = 2\pi \times 2 \quad t = 2\pi \text{ sec.}$$

2. $\delta_{\text{min}} = i + e - A$

$$\delta_{\text{min}} = A \text{ then}$$

$$2A = i + e \text{ in case of } \delta_{\text{min}} \quad i = e$$

$$2A = 2i \quad r_1 = r_2 = \frac{A}{2}$$

$$i = A = 90^\circ \text{ then } 1 \sin i = n \sin r_1$$

$$\sin A = n \sin \frac{A}{2}$$

$$2 \sin \frac{A}{2} \cos \frac{A}{2} = n \sin \frac{A}{2}$$

$$2 \cos \frac{A}{2} = n \text{ when } A = 90^\circ = i_{\text{max}}$$

$$\text{then } n_{\text{min}} = \sqrt{2} \quad i = A = 0 \quad n_{\text{max}} = 2$$

3. P.E. is maximum at extreme position and minimum at mean position.

Time to go from extreme position to mean position

$$\text{is, } t = \frac{T}{4}; \text{ where } T \text{ is time period of SHM}$$

$$5 \text{ s} = \frac{T}{4}$$

$$\Rightarrow T = 20 \text{ s.}$$

4. $\vec{d} = \vec{d}_f - \vec{d}_i = 8\hat{i} + 6\hat{j}$

$$W = \vec{F} \cdot \vec{d} = 24 + 24 = 48 \text{ J}$$

$$P_{av} = \frac{W}{t} = 8 \text{ Watt}$$

5. At max. extension both should move with equal velocity.

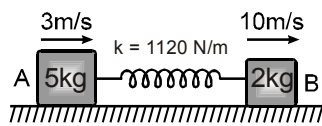

\therefore By momentum conservation,

$$(5 \times 3) + (2 \times 10) = (5 + 2)V$$

$$V = 5 \text{ m/sec.}$$

Now, by energy conservation

$$\frac{1}{2} \times 5 \times 3^2 + \frac{1}{2} \times 2 \times 10^2 = \frac{1}{2} (5 + 2)V^2 + \frac{1}{2} kx^2$$

Put V and k

$$\therefore x_{max} = \frac{1}{4} \text{ m} = 25 \text{ cm.}$$

Also first maximum compression occurs at ;

$$t = \frac{3T}{4} = \frac{3}{4} \times 2\pi \sqrt{\frac{\mu}{k}}$$

$$= \frac{3}{4} \times 2\pi \sqrt{\frac{10}{7 \times 1120}} = \frac{3\pi}{56} \text{ sec.}$$

(where $\mu \Rightarrow$ reduced mass, $\mu = \frac{m_1 m_2}{m_1 + m_2}$)

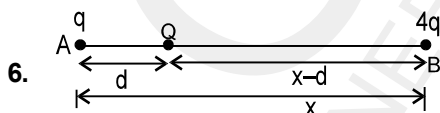

For equilibrium of all the charges net force on each charge should be zero.

$$\Rightarrow \frac{KqQ}{d^2} - \frac{4KqQ}{(x-d)^2} = 0 \text{ (Net force on Q)}$$

$$\Rightarrow d = x/3$$

$$\& \frac{KqQ}{d^2} + \frac{4Kq^2}{x^2} = 0 \text{ (Net force on A)}$$

$$\Rightarrow Q = -\frac{4}{9} q \ \& \ d = \frac{x}{3}$$

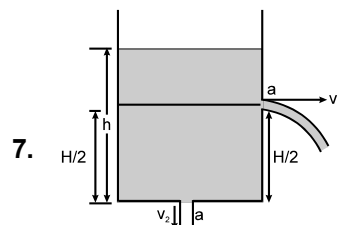

$$v_1 = \sqrt{2g(h - H/2)}$$

$$v_2 = \sqrt{2gh}$$

\therefore By continuity equation

$$A \left(-\frac{dh}{dt} \right) = a(v_1 + v_2)$$

$$\Rightarrow A \left(-\frac{dh}{dt} \right) = a \left\{ \sqrt{2g(h - H/2)} + \sqrt{2gh} \right\}$$

$$\text{or } -\frac{A}{a\sqrt{2g}} \int_0^{H/2} \frac{dh}{\sqrt{h} + \sqrt{h - H/2}} = \int_0^t dt$$

$$\Rightarrow t = \frac{2A}{3a} (\sqrt{2} - 1) \sqrt{\frac{H}{g}} \quad \text{Ans.}$$

8. Equation of standing wave can be written as

$$Y = 2 \sin(kx + \theta) \cos \omega t$$

because the particles at $t = 0$ are at extreme position.

$$k = \frac{2\pi}{\lambda} = \frac{2\pi}{4} = \frac{\pi}{2}$$

From the graph it is clear that $x = \frac{1}{2}$,

Amplitude = 0

$$\therefore 2 \sin \left[\frac{\pi}{2} \cdot \frac{1}{2} + \theta \right] = 0 \Rightarrow \frac{\pi}{4} + \theta = 0 \text{ or } \pi.$$

we will select $\frac{\pi}{4} + \theta = \pi$ to suit the initial condition

$$\therefore \theta = \frac{3\pi}{4}$$

$$\therefore y = 2 \sin \left(\frac{\pi}{2} x + \frac{3\pi}{4} \right) \cos \frac{5\pi}{2} t$$

$$= \sin \left(\frac{\pi}{2} x + \frac{3\pi}{4} + \frac{5\pi}{2} t \right)$$

$$+ \sin \left(\frac{\pi}{2} x + \frac{3\pi}{4} - \frac{5\pi}{2} t \right)$$

9. Distance of image of eye from fish in upward direction

$$d = \frac{d}{n_{rel}} + 30 = \frac{60}{\left(\frac{1}{\frac{4}{3}}\right)} = 60 \times \frac{4}{3} + 30$$

$$= 110 \text{ cm}$$

10. Distance of first image of eye from the refraction at water surface

$$v = \frac{60}{\left(\frac{1}{\frac{4}{3}}\right)} = 80$$

Distance of image of eye from mirror due to refraction = $80 + 60 = 140$

Distance of second image in downward direction from mirror = 140 cm

Distance of second image from fish in downward direction = $140 + 30 = 170 \text{ cm}$

DPP NO. - 15

1. $R = \sqrt{4^2 + 4^2 + 2 \cdot 4 \cdot 4 \cdot \cos 120^\circ} = 4\text{N}$

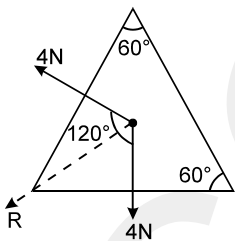

2. The force exerted by film on wire or thread depends only on the nature of material of the film and not on its surface area. Hence the radius of circle formed by elastic thread does not change.

3. $N = Mg(1 - \cos\theta)$

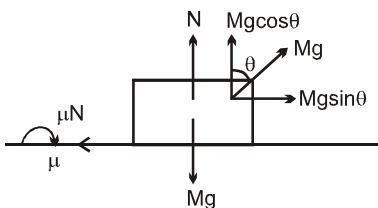

$$Mg \sin\theta > \mu Mg (1 - \cos\theta)$$

4. At time t_1 , velocity of the particle is negative i.e. going towards $-X_m$. From the graph, at time t_1 , its speed is decreasing. Therefore particle lies in between $-X_m$ and 0.

At time t_2 , velocity is positive and its magnitude is less than maximum i.e. it has yet not crossed 0. It lies in between $-X_m$ and 0.

Phase of particle at time t_1 is $(180 + \theta_1)$.

Phase of particle at time t_2 is $(270 + \theta_2)$

Phase difference is $90 + (\theta_2 - \theta_1)$

$\theta_2 - \theta_1$ can be negative making $\Delta\phi < 90^\circ$ but can not be more than 90° .

5. $\frac{\Delta A}{A} \times 100$

$$= 2 \left(\frac{\Delta \ell}{\ell} \right) \times 100$$

\Rightarrow % increase in Area

$$= 2 \times 0.2 = 0.4$$

$$\frac{\Delta V}{V} \times 100 = 3 \times 0.2 = 0.6 \%$$

Since $\Delta l = l \alpha \Delta T$

$$\frac{\Delta \ell}{\ell} \times 100$$

$$= \alpha \Delta T \times 100$$

$$= 0.2$$

$$\Rightarrow \alpha = 0.25 \times 10^{-4} / ^\circ\text{C}$$

6. Change in velocity = $\frac{\text{area under F-T graph}}{\text{mass}}$

$$= \frac{40 + (-10)}{5} = 6 \text{ m/s}$$

$$W_F = \Delta K.E. = \frac{1}{2} (5) 6^2 = 90 \text{ J}$$

7. Suppose acceleration of cylinder wrt plank is 'b' wrt plank.

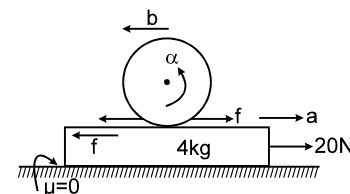

As there's no slipping $b = R\alpha$ (1)

Equation of Rotation motion $f \cdot R = I\alpha$.

$$\Rightarrow f = \frac{M_C R^2}{2 \cdot R} \cdot \frac{b}{R} = \frac{M_C b}{2} \quad \dots(2)$$

Linear motion of cylinder

$$f = M_c (a - b) \quad \dots(3)$$

for plank

$$20 - f = 4.a \quad \dots(4)$$

putting $M_c = 2\text{kg}$

$$f = b \quad 2f = 2(a - b)$$

$$\Rightarrow f = \frac{2a}{3}$$

$$\text{using in (4)} \quad 20 - \frac{2a}{3} = 4a$$

$$\Rightarrow a = \frac{30}{7} \text{ m/s}^2$$

$$\text{and } b = \frac{20}{7} \text{ m/s}^2$$

$$\text{Acceleration of cylinder} = a - b = \frac{10}{7} \text{ m/s}^2$$

$$[\text{Ans.: } a_1 = \frac{10}{7} \text{ m/s}^2, a_2 = \frac{30}{7} \text{ m/s}^2]$$

8. Apperent distance

$$(t) = \frac{d_1}{n_1/n_3} + \frac{d_2}{n_2/n_3} + d_3$$

$$\text{but } n_1 = n_3 = 1 \text{ \& } n_2 = 3/2$$

$$d = \frac{d_1}{1} + \frac{d_2}{3/2} + d_3$$

but d_2 and d_3 are constant when only object is moving.

$$\text{So } d' = d'_1 + 0 + 0 \Rightarrow v_1 = v_0 = 12 \text{ cm/sec.}$$

$$9. d' = \frac{d_1}{n_1/n_3} + \frac{d_2}{n_2/n_3} + d_3$$

$$= \frac{12}{1/4/3} + \frac{9}{3/2/4/3} + \frac{4}{1}$$

$$= 12 \times \frac{4}{3} + \frac{8}{1} + 4$$

$$= 16 + 8 + 4$$

$$= 28 \text{ cm.}$$

$$10. d' = \frac{d_1}{1/4/3} + \frac{d_2}{9/8} + d_3$$

$$v' = \frac{4v_1}{3} + 0 + 0$$

$$v' = \frac{4}{3} \times 12 = 16 \text{ cm/sec.}$$

2. (C)

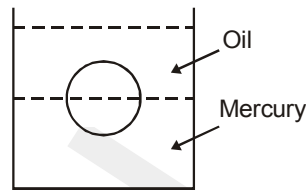

Weight = Buoyant force

$$V\rho_m g = \frac{V}{2} \rho_{\text{Hg}} g + \frac{V}{2} \rho_{\text{oil}}$$

$$r_m = \frac{\rho_{\text{Hg}} + \rho_{\text{oil}}}{2} = \frac{13.6 + 0.8}{2}$$

$$= \frac{14.4}{2} = 7.2$$

3. The friction force on coin just before coin is to slip will be :

$$f = \mu_s mg$$

$$f = \mu_s mg$$

Normal reaction on the coin ; $N = mg$

The resultant reaction by disk to the coin is

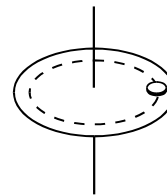

$$= \sqrt{N^2 + f^2}$$

$$= \sqrt{(mg)^2 + \mu_s^2 (mg)^2}$$

$$= mg \sqrt{1 + \mu^2}$$

$$= 40 \times 10^{-3} \times 10 \times \sqrt{1 + \frac{9}{16}} = 0.5 \text{ N}$$

4. Applying work-energy theorem,

$$\Sigma W_{\text{all forces}} = \Delta \text{K.E.}$$

$$W_g + W_N + W_f = \Delta \text{K.E.}$$

$$\Rightarrow (1 \times 10 \times 1) + 0 + W_f$$

$$= \frac{1}{2} (1)[(2)^2 - (0)^2]$$

$$10 + W_f = 2$$

$$W_f = -8 \text{ J.}$$

5. Velocity of sound in air $(V) = \sqrt{\frac{\gamma RT}{M}}$

$\Rightarrow V^2 \propto T$ (in kelvin)

not $V^2 \propto T$ (in $^{\circ}\text{C}$)

Hence (B) is incorrect.

Velocity of transverse wave in a string :

$V = \sqrt{\frac{T}{\mu}} = V^2 \propto T$

Hence (C) is a correct graph.

6. If we displace the electron slightly toward x direction, it will thrown away toward right.

So eq. is unstable along x direction.

If we displace the electron slightly towards y direction, No extra force will act. So eq. is neutral along y axis

If we displace the electron toward z direction, it will be attracted and try to come to eq. positron.

So eq. is stable along z direction.

7. [Ans. 1:1]

8. As it is possible only when, when light reflects from P_1 after refraction from the plate P_2 of light coming from light source.

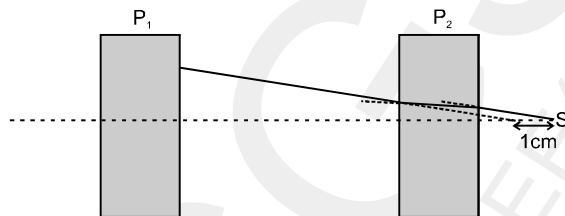

First image will form due to reflection from the right surface of P_1 . As light ray is falling on P_1 from 11 cm so it will form image at 11 cm in left. So, distance of first image from insect is $11 + 3 = 14$ cm.

9. Second image will form due to reflection on left surface of P_1 .

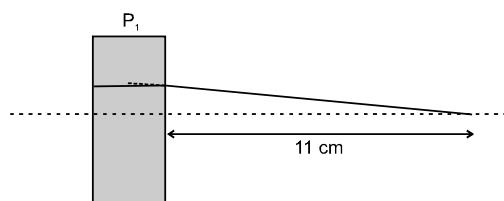

For left surface of P_1 light seems to coming from the

distance = $\frac{33}{2} + 3 = \frac{39}{2}$ cm

So, light seems to coming from $\frac{45}{2}$ cm from right

surfaces of P_1 .

So, final position of second image will be

$= \frac{\frac{45}{2}}{\frac{3}{2}} = 15$ cm.

So, distance of second image from insect = 18 cm.

10. Due to multiple reflections infinite image will be formed

DPP NO. - 17

1.

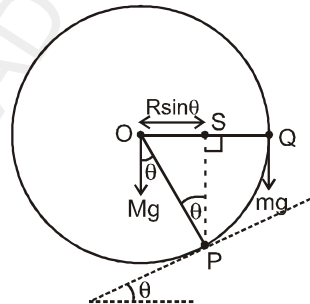

Let the radius of cylinder be R
 For the cylinder to remain static, net torque on cylinder about point P (point of contact with inclined surface) should be zero.

$\therefore Mg (OS) = mg (SQ)$
 or $Mg R \sin \theta = mg R (1 - \sin \theta)$

or $m = \frac{M \sin \theta}{1 - \sin \theta}$

2. (B) $y(x, t = 0) = \frac{6}{x^2}$ then $y(x, t)$

$= \frac{6}{(x - 2t)^2}$

$\Rightarrow \frac{\partial y}{\partial t} = \frac{24}{(x - 2t)^3}$

at $x = 2, t = 2$

$V_y = \frac{24}{(-2)^3} = -3$ m/s.

3. Area under the curve is equal to number of molecules of the gas sample. Hence

$$N = \frac{1}{2} \cdot a \cdot V_0 \Rightarrow aV_0 = 2N$$

$$V_{avg} = \frac{1}{N} \int_0^\infty v N(v) dv$$

$$= \frac{1}{N} \int_0^{V_0} C \cdot \left(\frac{a}{V_0} \cdot v\right) dv = \frac{2}{3} V_0 \Rightarrow \frac{V_{avg}}{V_0} = \frac{2}{3}$$

$$V_{rms}^2 = \frac{1}{N} \int_0^\infty v^2 N(v) dv$$

$$= \frac{1}{N} \int_0^{V_0} v^2 \left(\frac{a}{V_0} \cdot v\right) dv = \frac{V_0^2}{2} \Rightarrow \frac{V_{rms}}{V_0} = \frac{1}{\sqrt{2}}$$

Area under the curve from $0.5 V_0$ to V_0 is $\frac{3}{4}$ of total area.

4. $\Delta V_L = \Delta V_V$
 $\Rightarrow Y_L V_L = Y_V V_V$

or $\frac{Y_L}{Y_V} = \frac{V_V}{V_L}$

but $V_V > V_L$
 $\Rightarrow Y_L > Y_V$

5. $Y_1 = A \sin \omega t$
 $Y_2 = A \sin(\omega t + \phi) \quad \phi = 2\pi/3$

As, $Y_2 + Y_1 = A$

Now, solve and use the condition of maxima.

Alternate : by symmetry both should be on opposite side of mean position at equal distance from mean (for max. separation)

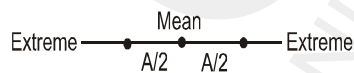

As projection of SHM on circular path

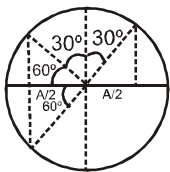

The phase difference from figure is $\frac{\pi}{6} + \frac{\pi}{6} = \frac{\pi}{3}$

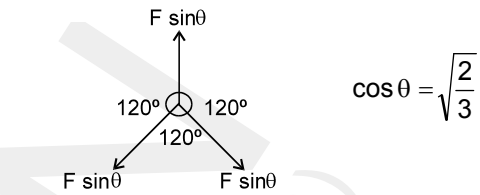
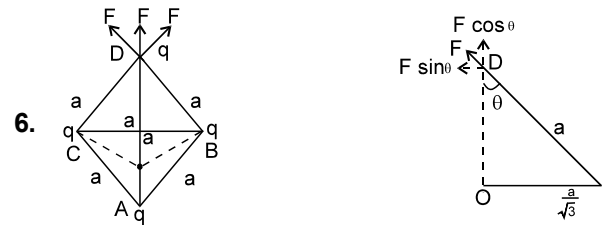

$$\therefore F_{net} = 3F \cos \theta = 3 \frac{Kq^2}{a^2} \sqrt{\frac{2}{3}}$$

$$= \frac{\sqrt{6} q^2}{4\pi \epsilon_0 a^2}$$

[Ans. $\frac{\sqrt{6} q^2}{4\pi \epsilon_0 a^2}$]

Sol. 7 to 9

7. F.B.D. of disc

\Rightarrow In horizontal direction $N = N_x \dots (1)$

In vertical direction $m'g - f - N_y = m'a \dots (2)$

Torque due to friction ;

$$fR = \frac{m'R^2}{2} \alpha$$

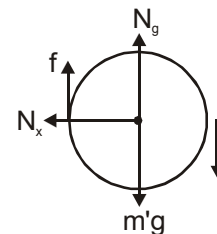

As $a = R\alpha$

$$\therefore fR = \frac{m'R^2}{2} \frac{a}{R}$$

$\Rightarrow f = \frac{m'a}{2}$ put in (2)

$$\therefore m'g - N_y = \frac{3m'a}{2}$$

$$N_y = m'g - \frac{3m'a}{2} \dots (3)$$

Now, F.B.D. of bar ;

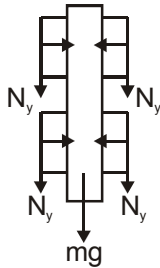

$$4N_y + mg = ma$$

Put N_y from (3)

$$4m'g - 6m'a + mg = ma \quad \dots (4)$$

As $m' = 2\text{kg}$ & $m = 5\text{kg}$

$$\therefore 8g - 12a + 5g = 5a$$

$$a = \frac{13g}{17} \downarrow$$

8. From equation (4) (neglecting m') $a = g \downarrow$

9. From equation (4) (neglecting m) $a = \frac{2g}{3} \downarrow$

10. (A) $\rightarrow p, s$; (B) $\rightarrow r$; (C) $\rightarrow r$; (D) $\rightarrow p, s$

DPP NO. - 18

1. Loss in heat from calorimeter + water as temperature changes from 10°C to 0°C

$$= m_1 C_1 10 + m_2 C_2 10$$

$$= 1 \times 1 \times 10 + 1 \times 0.1 \times 10 = 11 \text{ kcal}$$

Gain in heat of ice as its temperature changes from -11°C to 0°C

$$= m_3 C_3 \times 11 = 2 \times 0.5 \times 11 = 11 \text{ kcal}$$

Hence ice and water will coexist at 0°C without any phase change.

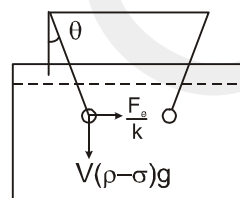
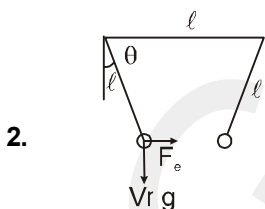

$$\tan\theta = \frac{F_e}{V\rho g} = \frac{F_e/k}{V(\rho - \sigma)g}$$

$$\Rightarrow k = \frac{\rho}{\rho - \sigma} = \frac{2.4}{2.4 - 0.8} = 1.5$$

$$k = \frac{\rho}{\rho - \sigma} = \frac{2.4}{2.4 - 0.8} = 1.5$$

3. Because the acceleration of wedge is zero, the normal reaction exerted by wedge on block is $N = mg \cos 37^\circ$.

The acceleration of the block is $g \sin 37^\circ$ along the incline and initial velocity of the block is $v = 10 \text{ m/s}$ horizontally towards right as shown in figure.

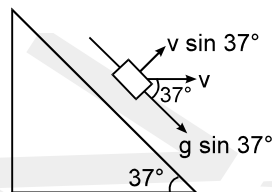

The component of velocity of the block normal to the incline is $v \sin 37^\circ$. Hence the displacement of the block normal to the incline in $t = 2$ second is

$$S = v \sin 37^\circ \times 2 = 10 \times \frac{3}{5} \times 2 = 12 \text{ m.}$$

\therefore The work done by normal reaction

$$W = mg \cos 37^\circ \times S = 100 \times \frac{4}{5} \times 12 = 960 \text{ J}$$

4. Since, the medium has not changed, speed of wave remains same.

$$\Rightarrow v = f\lambda = \text{constant}$$

$$f_1 \lambda_1 = f_2 \lambda_2$$

$$\Rightarrow f_1 \lambda_1 = (1.25 f_1) \lambda_2$$

(\because frequency increased by 25%)

$$\Rightarrow \lambda_2 = \frac{\lambda_1}{1.25}$$

$\Rightarrow \lambda_2$ decreases.

\Rightarrow % change in wavelength

$$= \frac{\lambda_1 - \lambda_2}{\lambda_1} \times 100 = \frac{\lambda_1 - \frac{\lambda_1}{1.25}}{\lambda_1} \times 100$$

$$= \frac{0.25}{1.25} \times 100 = \frac{100}{5} = 20\%$$

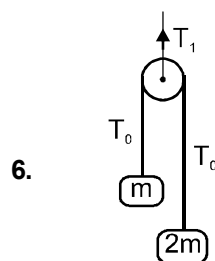

$$T_1 = 2T_0 = 2 \left[\frac{2m(2m)}{m + 2m} \right] g$$

$$T_1 = \frac{8m}{3}g = \frac{80m}{3} \dots\dots\dots(i)$$

In resonance,

$$f_{\text{wire}} = f_{\text{tube}}$$

$$\frac{(1)V_1}{2l_1} = \frac{(1)V_2}{4l_2}$$

$$\frac{\left(\sqrt{\frac{T_1}{\mu}}\right)}{2(x)} = \frac{(400)}{4\left(\frac{x}{2}\right)}$$

$$\Rightarrow T_1 = \mu(16 \times 10^4)$$

From (i),

$$\frac{80}{3}m = 10^{-4}(16 \times 10^4)$$

$$m = 0.6 \text{ kg.}$$

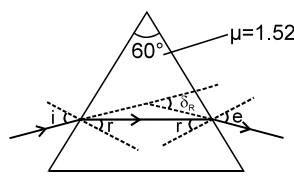

7.

$$\mu_R = 1.52$$

$$\mu_v = 1.6$$

Minimum deviation condition for red is $r = 30^\circ$

$$\Rightarrow (1) \sin i = (1.52) \sin 30^\circ$$

$$i = 50^\circ,$$

$$\delta_R = (50^\circ) 2 - 60^\circ$$

$$= 40^\circ$$

8. For violet light

$$(1) \sin 50^\circ = (1.6) \sin r$$

$$\therefore r = 28.4^\circ$$

$$r' = 31.6^\circ \quad (\because r + r' = A)$$

$$(1) \sin e = (1.6) \sin 31.6^\circ$$

$$\therefore e = 56^\circ,$$

$$\Rightarrow \delta_v = i + e - A = 50^\circ + 56^\circ - 60^\circ$$

$$= 46^\circ$$

$$\therefore \text{angular width} = \delta_v - \delta_R = 6^\circ$$

9. The length of the spectrum if it is focussed on a screen by a lens of focal length 100 cm is :

(A*) $\frac{10\pi}{3}$ cm

(B) $\frac{10\pi}{3}$ m

(C) $\frac{5\pi}{3}$ cm

(D) $\frac{5\pi}{3}$ m

Sol. if $\theta = 100 \times 6 \times \frac{\pi}{180}$ cm = $\frac{10\pi}{3}$ cm

10. (A) \rightarrow (p, r, s), (B) \rightarrow (p, s), (C) \rightarrow (r, s), (D) \rightarrow (q, s)

1. The FBD of rod is
Taking moment of force about centre of mass

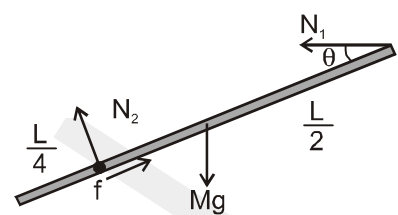

$$N_2 \times \frac{L}{4} - N_1 \sin \theta \times \frac{L}{2} = 0$$

$$\therefore \frac{N_1}{N_2} = \frac{1}{2 \sin \theta}$$

2. $E = \int dE = \int_{x=a}^b \frac{2K\sigma dx}{x} = 2K\sigma \ln \frac{b}{a}$

$$V = \int dV = \int_{x=a}^b \frac{K\pi x \sigma dx}{x} = K\sigma \pi (b-a).$$

$$\Rightarrow \frac{E}{V} = \frac{2k\sigma \ln(b/a)}{k\sigma \pi (b-a)} = \frac{\ln(b/a)^2}{\pi(b-a)}$$

3.

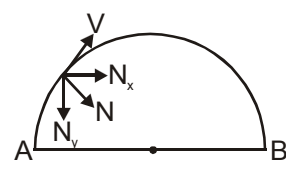

The horizontal component of velocity of Q will increase and become maximum at the top ; and will again become same at B. Because of its greater horizontal velocity the particle Q will reach B earlier than P
 $\therefore t_1 > t_2$.

4. Given : $f_0 = 200 \text{ Hz.}, A = 50 \text{ cm} = 0.5 \text{ m}, V = 340 \text{ m/s.}$
According to question :

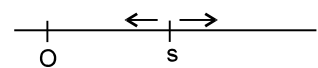

$$\frac{2f_0(V_s)_{\text{max}}}{V} = 20 \Rightarrow 20$$

$$= \frac{2 \times 200 \times 0.5 \times \omega}{340} \quad (\text{since } (V_s)_{\text{max}} = A\omega)$$

$$\Rightarrow \omega = 34 \text{ rad/s.}$$

5. B,C,D direction of friction do not depend on direction of force but it depends on direction of relative motion (velocity)

6. a

9. (i) By conservation of volume
 $4 \times h = 4 \times 2 + 2 \times 1 = 10$
 $h = 2.5\text{m}$
 Pressure at top of the object
 $= P_0 + 0.5 \times 1000 \times 10$
 $= 1.05 \times 10^5 \text{ N/m}^2$
 $F = P_1 A$
 $= 1.05 \times 10^5 \times 2 = 2.1 \times 10^5 \text{ N}$

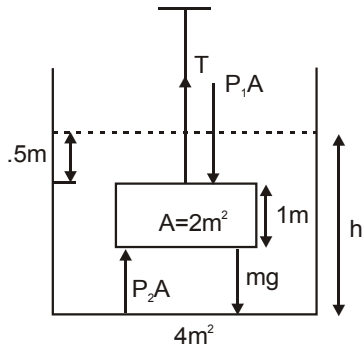

By F.B.D.

$$T + P_2 A = mg = P_1 A$$

$$T = mg + (P_1 - P_2) A$$

$$= mg - (P_2 - P_1) A$$

$$= 2 \times 2000 \times 10 - (.2 \times 10^5)$$

$$= .4 \times 10^5 - 0.2 \times 10^5 = 0.2 \times 10^5 \text{ N}$$

$$F_b = V \cdot \rho_w \cdot g$$

$$= 2 \times 1000 \times 10 = 0.2 \times 10^5 \text{ N}$$

It is also equal to net contact force by the liquid $= P_2 A - P_1 A = 0.2 \times 10^5 \text{ N}$

Note : Net contact force and buoyant force are same.

10. (A) q,r (B) p,s (C) p,s (D) p,s
 (A) Centre of mass lies in second quadrant.
 (B), (C) and (D) Centre of mass lies on y-axis and below x-axis.

DPP NO. - 20

1. (Moderate) Draw an incident ray along the top side of rectangular strip, which happens to be parallel to the principal axis. After reflection this ray passes through focus. Hence image of all points (for e.g. O_1, O_2, O_3, \dots) on top side of the strip lie on this reflected ray (at I_1, I_2, I_3, \dots) in between focus and centre of curvature. Thus the image of this strip is a triangle as shown in figure

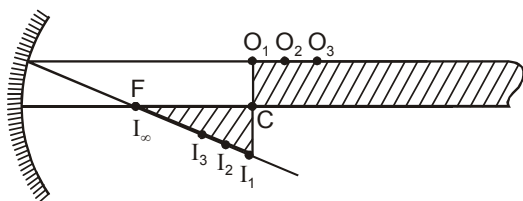

$$2. V_{\text{rms}} = \sqrt{\frac{V_1^2 + V_2^2 + \dots + V_N^2}{N}}$$

$$= \sqrt{\frac{1^2 + 2^2 + \dots + N^2}{N}}$$

$$= \sqrt{\frac{N(N+1)(2N+1)}{6N}}$$

$$\Rightarrow V_{\text{rms}} = \sqrt{\frac{(N+1)(2N+1)}{6}}$$

$$V_{\text{avg}} = \frac{V_1 + V_2 + \dots + V_N}{N} = \frac{1+2+\dots+N}{N}$$

$$= \frac{N(N+1)}{2N} = \frac{N+1}{2}$$

$$\frac{V_{\text{rms}}}{V_{\text{avg}}} = 2 \sqrt{\frac{(2N+1)}{6(N+1)}}$$

4. The magnitude of phase difference between the points separated by distance 10 metres
 $= k \times 10 = [10\pi \times 0.01] \times 10 = \pi$

5. At E,

$$E_E = E_A - E_B$$

$$= \frac{2/\pi \times 10^{-9}}{2 \cdot \epsilon_0} - \frac{1/\pi \times 10^{-9}}{2 \cdot \epsilon_0}$$

= 18, towards right.

At D

$$E_D = E_A + E_B$$

$$= \frac{(2/\pi) \times 10^{-9}}{2 \epsilon_0} + \frac{(1/\pi) \times 10^{-9}}{2 \epsilon_0} = 54,$$

towards right.

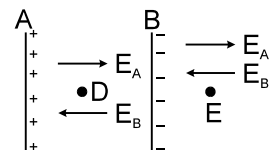

6. (a) from $y-x$ graph
 wavelength $= \lambda = 6\text{m}$

from $y-t$ graph

Time period $= T = 4 \text{ sec}$

$$\Rightarrow \text{frequency} = f = \frac{1}{4} = 0.25 \text{ Hz}$$

wave speed $= f\lambda = 0.25 \times 6 = 1.50 \text{ m/s}$

(b) maximum velocity $= 3\text{mm} \times \frac{\pi}{2} \text{ rad/sec}$

$= 1.5 \pi \text{ mm/sec}$

9. When the block comes to rest, the wedge continues to move at $V = \frac{u}{2} = \sqrt{gH}$ on the smooth surface. (since, momentum of wedge-block system remains conserved).

10. By work-energy theorem of the block :

$$-(\mu mg)(BD) - mg(H-h) = 0$$

$$BD = \frac{H-h}{\mu}$$